

# **Agricultural Construction Volume III**

Writers:

Craig W. Gladney, Janis L. Levsen, Susan Rhyne, and Patricia DeFacio  
Instructional Materials Laboratory  
University of Missouri-Columbia

Produced by:

Instructional Materials Laboratory  
University of Missouri-Columbia  
10 London Hall  
Columbia, Missouri 65211

Volume 34  
Number 7

Catalog Number 10-7143-I

Available from:  
Instructional Materials Laboratory  
University of Missouri  
2316 Industrial Drive  
Columbia, Missouri 65202  
573-882-2883  
800-669-2465

**© 2002 Curators of the University of Missouri. All rights reserved.**

The activity that is the subject of this report was supported in whole or in part by funds from the Department of Elementary and Secondary Education, Division of Vocational and Adult Education. However, the opinions expressed therein do not necessarily reflect the position or policies of the Missouri Department of Elementary and Secondary Education or the Division of Vocational and Adult Education, and no official endorsement should be inferred.

# Agricultural Construction

## Table of Contents

Competencies/Objectives.....	1
<b>Unit I – Oxy-Gas and Other Cutting/Welding Processes</b>	
<b>Arc Cutting and Plasma Air Cutting</b> .....	1
TM 1.1 Schematic of Air Carbon-Arc Gouging.....	15
TM 1.2 Schematic of Plasma-Arc Cutting.....	17
DM 1.1 Air Carbon-Arc Cutting.....	19
DM 1.2 Plasma-Arc Cutting.....	21
JS 1.1 Air Carbon-Arc Cutting.....	23
JS 1.2 Plasma-Arc Cutting.....	27
<b>Unit II –Arc Welding</b>	
<b>Gas Metal Arc Welding (GMAW)/MIG</b> .....	29
DM 2.1 Prewelding and Postwelding Procedures for GMAW.....	39
DM 2.2 Welds in the Flat Position.....	41
DM 2.3 Welds in the Horizontal Position.....	43
DM 2.4 Welds in the Vertical Position.....	45
DM 2.5 Welds in the Overhead Position.....	49
JS 2.1 Prewelding and Postwelding Procedures for GMAW.....	51
JS 2.2 Welds in the Flat Position.....	53
JS 2.3 Welds in the Horizontal Position.....	55
JS 2.4 Welds in the Vertical Position.....	57
JS 2.5 Welds in the Overhead Position.....	61
<b>Unit III – Arc Welding</b>	
<b>Gas Tungsten Air Welding (GTAW)/TIG</b> .....	63
DM 3.1 Prewelding and Postwelding Procedures for GTAW.....	73
DM 3.2 Welds in the Flat Position.....	75
DM 3.3 Welds in the Horizontal Position.....	79
DM 3.4 Welds in the Vertical Position.....	83
DM 3.5 Welds in the Overhead Position.....	87
JS 3.1 Prewelding and Postwelding Procedures for GTAW.....	91
JS 3.2 Welds in the Flat Position.....	93
JS 3.3 Welds in the Horizontal Position.....	97
JS 3.4 Welds in the Vertical Position.....	101
JS 3.5 Welds in the Overhead Position.....	105



## COMPETENCIES/OBJECTIVES

### **Unit I – Oxy-Gas and Other Cutting/Welding Processes**

1. Cut a piece of metal using air carbon-arc and plasma arc cutting processes.

### **Unit II – Arc Welding**

1. Make a series of welds in a variety of positions using gas metal arc welding.

### **Unit III – Arc Welding**

1. Make a series of welds in a variety of positions using gas tungsten arc welding.



# UNIT I - OXY-GAS AND OTHER CUTTING/ WELDING PROCESSES

## Arc Cutting and Plasma-Arc Cutting \*

### Objective

The student will be able to cut a piece of metal using air carbon-arc and plasma arc cutting processes.

### Study Questions

1. What is air carbon-arc cutting?
2. What equipment is necessary for air carbon-arc cutting?
3. What different types of cutting can be done with air carbon-arc?
4. What are the advantages of air carbon-arc cutting?
5. What is plasma-arc cutting?
6. What equipment is necessary for plasma-arc cutting?
7. What types of metal can be cut with plasma-arc?
8. What are the advantages of plasma-arc cutting?
9. What safety precautions and maintenance considerations should be observed for air carbon-arc cutting?
10. What safety precautions and maintenance considerations should be observed for plasma-arc cutting?

### References

1. Althouse, A.D.; Turnquist, C.H.; Bowditch, W.A.; Bowditch, K.E. Modern Welding. The Goodheart-Willcox Company, Inc., Tinley Park, IL: 2000.
2. Giachino, Joseph W.; William Weeks. Welding Skills. American Technical Publishers, Alsip, NY: 1986.
3. Hidden, Steve. Plasma Cutting Safety Makes Sense. Miller Electric Mfg. Co. <http://www.millerwelds.com/pdf/techart/Plassaf.html> accessed 6/12/02.

---

\* Plasma-arc cutting is not listed on the competency profile for Agricultural Construction. If this skill is taught, it should be added in one of the blanks provided on the profile.

# Agricultural Construction

---

4. Jeffus, L. Welding Principles and Applications (4th ed). Delmar Publishers, Albany, NY: 1999.
5. Sacks, R.J. Essentials of Welding. Bennett Publishing Company, Peoria, IL: 1984.
6. Welding Theory and Application. Training Circular No. 9-237. Department of the Army, 1993, <http://www.adtdl.army.mil/cgi-bin/atdl.dll/tc/9-237/toc.htm> accessed 6/20/02.
7. What Is Plasma Cutting? PlasmaCAM Inc., 2000. <http://www.plasmacam.com/cnchow.htm> accessed 6/18/02.
8. Transparency Masters
  - a) TM 1.1: Schematic of Air Carbon-Arc Gouging
  - b) TM 1.2: Schematic of Plasma-Arc Cutting
9. Demonstration Sheets
  - a) DS 1.1: Air Carbon-Arc Cutting
  - b) DS 1.2: Plasma-Arc Cutting
10. Job Sheets
  - a) JS 1.1: Air Carbon-Arc Cutting
  - b) JS 1.2: Plasma-Arc Cutting



---

## UNIT I - OXY-GAS AND OTHER CUTTING/ WELDING PROCESSES

### Arc Cutting and Plasma-Arc Cutting

#### TEACHING PROCEDURES

##### A. Review

Review Unit I, Lesson 1 of Agricultural Construction (Volume I) for safe use of the AC-DC welder. Also review and discuss the previous lessons regarding cutting metal with oxy-gas.

##### B. Motivation

Some shops do not have an oxy-gas cutting unit available for use. With the use of an available AC-DC arc welding machine, the cutting process can be accomplished. Show the students the different pieces of metal cut with air carbon-arc and oxy-acetylene, and let them decide which piece was cut with which method.

##### C. Assignment

##### D. Supervised study

##### E. Discussion

There are several methods that can be used to cut metal. Ask the students to describe the different cutting methods they have used in the shop. Discuss the air carbon-arc cutting process as an alternative. Refer to TM 1.1.

**1. What is air carbon-arc cutting?** (Refer to TM 1.1 Schematic of Air Carbon-Arc Gouging.)

- a) Air carbon-arc cutting, formerly called arc-air cutting, is a process in which metal is cut (melted) by the heat produced from the arc between a carbon electrode and the base metal.
- b) The molten metal from the cut is removed by a stream of compressed air.
  - 1) The air stream flows under the electrode (between the electrode and the base metal).
  - 2) The air stream is directed to the arc.
- c) No filler metal or shielding gas is used in air carbon-arc.

In order to use the air carbon-arc process with an arc welder, special equipment must be added. Show students the equipment necessary to accomplish air carbon-arc cutting?

**2. What equipment is necessary for air carbon-arc cutting?**

- a) Arc welding machine

## Agricultural Construction

---

- 1) Voltage requirements for air carbon-arc are generally higher than voltage requirements for shielded metal arc welding (SMAW).
- 2) Check the manufacturer's information for the welding machine to ensure the equipment is approved for air carbon-arc processes.
- b) Air compressor or compressed air in cylinders
  - 1) The air supply must be of sufficient pressure and airflow to remove the molten metal and produce a clean cut or gouge.
  - 2) The air supply should have little or no abrasive particles or moisture.
  - 3) Compressed air in cylinders can be used when portability is required.
- c) Air carbon-arc torch (also called air carbon-arc electrode holder)
  - 1) This torch is similar to the SMAW electrode holder, but the air carbon-arc torch has the following additional features:
    - a. Passageway for air
    - b. Air holes in the lower jaw of the torch
    - c. Only one groove for the electrode
    - d. Jaw that can pivot
    - e. Air valve for turning the air on and off
  - 2) Torches are available for a variety of amperage settings.
- d) Air carbon-arc electrodes
  - 1) Features of air carbon-arc electrodes include the following:
    - a. Made of carbon and graphite
    - b. Available in round, flat, and semi-round shapes and various diameters
    - c. Designed for use with AC or DC current
    - d. Available with no coating (plain) and with a copper coating
    - e. Some designed to connect together to reduce waste of electrode stubs
  - 2) The electrodes for direct current electrode positive (DCEP) are the most frequently used.
  - 3) The diameter of the electrode determines the width of the cut or groove.
- e) Air hose
  - 1) The air hose and the electrode lead are frequently connected together. The connection is covered by an insulated boot.
  - 2) The inside diameter of the hose must be approved for the type of torch being used.
- f) Electrode lead - attached to the welding machine and the air hose
- g) Ground lead with clamp - attached to the welding machine and the workpiece

Ask the students to list the different types of cutting that can be accomplished using the air carbon-arc torch. Show the students examples of each cutting process.

### 3. What different types of cutting can be done with air carbon-arc?

- a) Gouging - cutting a groove in metal
- b) All-purpose cutting - cutting all the way through metal
- c) Washing - removing the surface area of metal
- d) Beveling - cutting an angle on the edge of metal

Air carbon-arc cutting has several advantages over other cutting methods. Ask the students to list advantages of using air carbon-arc over other cutting methods.

#### 4. What are the advantages of air carbon-arc cutting?

- a) An arc welding machine may be used with a small investment for the additional equipment.
- b) The process is a relatively inexpensive way to cut most metals.
- c) Repair work, such as removing old welds, can be done quickly and easily with little or no cleanup required.
- d) The chances of distortion or cracking are reduced, because the heat from air carbon-arc is limited to a small area of the metal and the molten metal is removed quickly.
- e) The oxidation characteristics of metal are not a factor because the air stream removes the molten metal. As a result, many types of metal can be cut with air carbon-arc.

Plasma-arc cutting is regarded as one of the best and fastest methods for high-speed cutting of nonferrous metals and stainless steels. Ask the students to describe plasma-arc cutting.

#### 5. What is plasma-arc cutting?

- a) Plasma-arc cutting is a high-speed cutting process that uses an electric arc and fast-flowing ionized gases to cut metals.
- b) The electric arc passes through a large quantity of gas that travels through a nozzle. Gases used include argon, hydrogen, nitrogen, shop air, or oxygen.
- c) The electric arc heats the gas to such a high temperature that it turns into “plasma” - the fourth state of matter.
- d) The heat of the plasma is released into the metal workpiece through the tip of an electrode that is located in the nozzle.
- e) As the gas is heated, it is forced through the tip at a very high rate of speed.
- f) The intense heat then cuts through the metal.

Special equipment is needed in order to cut metal with the plasma-arc process. Ask students to list the equipment needed. Use TM 9.2 to illustrate the equipment used in plasma-arc cutting.

#### 6. What equipment is necessary for plasma-arc cutting? (Refer to TM 1.2 Schematic of Plasma-Arc Cutting.)

- a) Power source to convert AC-line voltage into direct current (DC ) that the user can regulate
  - 1) Up to 700 amperes (A) at 170 volts for cutting 5-in. piece of aluminum
  - 2) 400 A to cut 1.5-in. piece of aluminum or 1-in. piece of steel
- b) A control unit to automatically control the sequence of operations
- c) Air compressor
- d) Cooling water pumps and water-cooled leads
- e) Shielding gas(es) under pressure
- f) Plasma torch:
  - 1) Nozzle
  - 2) Nozzle insulator

## Agricultural Construction

---

- 3) Nozzle tip
- 4) Nozzle guide
- 5) Electrode tip
- g) Gas regulator
- h) Electric cables
- i) Ground clamp

Ask the students to list the different types of metal that can be cut using plasma-arc. Show students examples of each.

### **7. What types of metal can be cut with plasma-arc?**

- a) Any nonferrous metal
- b) Stainless steel
- c) Carbon steel

Based on the characteristics discussed in previous questions, ask students what the advantages would be for plasma-arc cutting.

### **8. What are the advantages of plasma-arc cutting?**

- a) Very high speed - cuts faster than oxy-fuel
- b) Clean - uses clean, dry air
- c) Light (less than 50 lb), small, and portable
- d) Used for stack cutting, shape cutting, gouging, beveling, and piercing
- e) Equal quality to other operations
- f) Economical to use when needing a lot of precise cuts
- g) Safer than oxy-fuel gas cutting

Safety precautions and maintenance are very important to follow when air carbon-arc cutting. Discuss with students additional precautions and maintenance considerations that should be observed to prevent injury.

### **9. What safety precautions and maintenance considerations should be observed for air carbon-arc cutting?**

- a) Observe all safety precautions that are appropriate for SMAW. Review safety precautions for SMAW in Agricultural Construction (Volume I), Unit I, Lesson 1, as needed. Additional safety precautions specific to air carbon-arc cutting are listed below.
- b) Protect the body from the sparks produced by the process. In addition, protect others in the work area, equipment, and other materials from sparks.
- c) Protect the body, others in the work area, equipment, and other materials from flying molten metal.
  - 1) Cut away from the operator.
  - 2) Use a metal deflection plate to block the travel of molten metal.
  - 3) Remove all combustible materials from the work area.

- d) Wear ear protection to prevent hearing damage. A high level of sound is generated from the high amperage and air pressure used.
- e) Wear additional protective clothing to protect the body from arc light burns. The chance of being burned by arc light during air carbon-arc cutting is higher than during SMAW because the light is more intense. Clothing recommendations are as follows:
  - 1) Thicker clothing
  - 2) Leather jacket
  - 3) Leather apron
- f) Wear a welding helmet with a #12 to #14 lens shade to protect the eyes from arc light burns. The lens shade necessary for air carbon-arc cutting is darker than the one needed for SMAW. Consult the manufacturer's recommendations for the appropriate lens.
- g) Avoid the hazardous fumes given off by air carbon-arc cutting.
  - 1) Work in an adequately ventilated area.
  - 2) Wear an appropriate respirator, if needed.
  - 3) Clean the workpiece to remove paint, grease, chemicals, or other contaminants that could create hazardous fumes.
- h) Do not use oxygen instead of air for air carbon-arc cutting. Oxygen is flammable.
- i) Replace worn leads, cables, and hoses and broken connections to prevent electrical shock. Repairing leads, cables, and hoses with tape is not acceptable.
- j) Inspect the air carbon-arc torch frequently to be sure it is not damaged or in need of repair.
- k) Protect leads, cables, and hoses from fire or other damage.
  - 1) Keep leads, cables, and hoses free of oil and grease.
  - 2) Run leads, cables, and hoses so that they will not be damaged or cause a tripping hazard.
- l) Keep the arc welding machine, electrodes, and work area dry.
- m) Do not allow the electrode to come in contact with any metal parts while the arc welding machine is on. If the electrode touches metal, a short could occur.

Continue the discussion about safety precautions and maintenance for plasma-arc cutting.

### **10. What safety precautions and maintenance considerations should be observed for plasma-arc cutting?**

- a) Observe all safety procedures. Always point the torch away from the body and toward the workpiece.
- b) Protect eyes by wearing safety glasses with a side shield and also use a face shield or helmet.
- c) Wear the proper lens shade based on the machine's amperage capabilities.
  - 1) Up to 300 A - #9 lens shade
  - 2) 300-400 A - #12 lens shade
  - 3) 400-800 A - #14 lens shade
- d) Because plasma can cut anything that conducts electricity, extremities (hands, fingers, toes) can be severely burned or injured if not protected.
  - 1) Wear leather gloves that are hole-free and dry.
  - 2) Wear high-top leather shoes or boots.
- e) Select clothing made of tightly woven material, such as wool, heavy denim, or leather. Keep clothing dry at all times.
- f) Button shirt collars, cuffs, and front pockets. Do not wear cuffed pants.

## Agricultural Construction

---

- g) Protect against excessive noise.
  - 1) Add room acoustics.
  - 2) Reduce intensity of noise.
  - 3) Wear ear muffs or ear plugs.
  - 4) Cut under water.
- h) Stay away from flammable gases, vapors, dust, and liquids. All flammable materials must be at least 35 ft away from the cutting area or encased in flame-proof containers.
- i) Keep the work area dry.
- j) Avoid inhaling fumes (hold head to the side of the torch). Keep work area well ventilated. If necessary, wear an air-supplied respirator.
- k) Remove coatings from the cutting areas of galvanized steel, cadmium- or lead-plated steel because they contain elements that emit toxic fumes.
- l) Replace - do not repair - worn cables or broken connections to prevent electrical shock.
- m) Ensure the cutting equipment is properly grounded.
- n) If using cylinders of compressed nitrogen, be sure to chain them to an upright, stable support.
  - 1) When moving the cylinder, place a threaded protector cap on top.
  - 2) Remove faulty regulators and send them to the manufacturer for repair.
- o) To connect hoses to fittings, use only recommended wires or ferrules, never ordinary wire or other replacements.
- p) Keep hoses off of the ground to prevent damage.
  - 1) Examine all hoses for leaks.
  - 2) Do not let hoses become tangled.
  - 3) Replace worn or leaky hoses. Do not splice them with tape because this does not provide a safe seal.
- q) When the electrode and nozzle wear out, replace them.

### F. Other activities

1. Check with area equipment/service dealers to see if there are any films available on air carbon-arc cutting.
2. Make a bulletin board showing all the different methods available for cutting metal.

### G. Conclusion

Air carbon-arc cutting is another option for cutting metal. This process uses an arc to heat metal to its melting point and then removes the molten metal with a stream of compressed air. Air carbon-arc cutting equipment is used in combination with an arc welding machine and can be installed for a small investment. Plasma-arc cutting is a procedure in which the heat of the electric arc reaches such a high temperature that the gas converts into plasma, the fourth state of matter. The operation may be automatic or semi-automatic. It is used when multiple cuts must be made identically or when a clean cut is desired. Cuts made with this process are much smoother and safer than those made with oxy-fuel gas cutting or air carbon-arc processes. In addition, it is economical.

## H. Competency

Perform cutting with air carbon-arc.

- \* Only air carbon-arc cutting is listed on the Agricultural Construction competency list. An additional competency for plasma-arc cutting may be added in the blank space at the end of the list.

## I. Answers to Evaluation

1. a
2. e
3. e
4. d
5. Three of the following: an arc welding machine may be used with a small investment for the additional equipment; the process is a relatively inexpensive way to cut most metals; repair work can be done quickly and easily with little or no cleanup required; the chances of distortion or cracking are reduced with air carbon-arc cutting; many types of metal can be cut with air carbon-arc because the oxidation characteristics of metal are not a factor
6. Six of the following: observe all safety precautions that are appropriate for SMAW; protect the body, others in the work area, equipment, and other materials from sparks; protect the body, others in the work area, equipment, and other materials from flying molten metal; wear ear protection to prevent hearing damage; wear additional protective clothing to protect the body from arc light burns; wear a welding helmet with a #12 to #14 lens shade to protect the eyes from arc light burns; avoid the hazardous fumes given off by air carbon-arc cutting; do not use oxygen instead of air for air carbon-arc cutting.
7. Work in an adequately ventilated area; wear an appropriate respirator, if needed; clean the workpiece to remove paint, grease, chemicals, or other contaminants that could create hazardous fumes
8. Three of the following: replace worn leads, cables, and hoses and broken connections to prevent electrical shock; inspect the air carbon-arc torch frequently to be sure it is not damaged or in need of repair; protect leads, cables, and hoses from fire or other damage; keep the arc welding machine, electrodes, and work area dry; do not allow the electrode to come in contact with any metal parts while the arc welding machine is on
9. Four of the following: very high speed; clean; light, small, and portable; used for stack cutting, shape cutting, gouging, beveling, and piercing; equal quality to other operations; economical; safer than oxy-fuel gas cutting
10. Any nonferrous metal, stainless steel, carbon steel
11. Six of the following: observe all safety procedures; protect eyes by wearing safety glasses with a side shield and also use a face shield or helmet; wear the proper lens shade; protect extremities; wear tightly woven clothes; button shirt collars, cuffs, and front pockets; do not wear cuffed pants; protect against excessive noise; stay away from flammable gases; keep the work area dry; avoid inhaling fumes; remove coating from the cutting areas of galvanized steel, cadmium- or lead-plated steel
12. Three of the following: add room acoustics, reduce intensity of noise, wear ear muffs or ear plugs; cut under water

## Agricultural Construction

---

13. Five of the following: replace - do not repair - worn cables or broken connections; ensure the cutting equipment is properly grounded; chain nitrogen cylinders to upright, stable support; when moving cylinder, place a threaded protector cap on top; remove faulty regulators and send them to the manufacturer for repair; to connect hoses to fittings, use only recommended wires or ferrules; keep hoses off of the ground; examine all hoses for leaks; do not let hoses become tangled; replace worn or leaky hoses, but do not splice them with tape; when electrode and nozzle wear out, replace them
14. When the electric arc heats gas to an extremely high temperature
15. #14



## UNIT I - OXY-GAS AND OTHER CUTTING/ WELDING PROCESSES

### Arc Cutting and Plasma-Arc Cutting

#### EVALUATION

Circle the letter that corresponds to the best answer.

1. Which type of cutting is used to make an angle on the edge of metal?
  - a. Beveling
  - b. Cutting
  - c. Gouging
  - d. Shearing
  - e. Washing
2. Which of the following statements is correct about the equipment used for air carbon-arc cutting?
  - a. An oxygen cylinder can be used for the air supply.
  - b. Electrodes are available in round, square, and oval shapes.
  - c. The air hose and ground lead are frequently connected together.
  - d. The torch has the same design as the electrode holder used in SMAW.
  - e. The ground lead is attached to the welding machine and the workpiece.
3. One way that air carbon-arc differs from other cutting processes is that it uses:
  - a. argon gas.
  - b. special fillers.
  - c. compressed nitrogen.
  - d. carbon electrodes and filler.
  - e. no filler metal or shielding gas.
4. When comparing air carbon-arc cutting to SMAW, air carbon-arc cutting:
  - a. generates less noise.
  - b. uses more filler metal.
  - c. does not produce sparks.
  - d. requires a darker lens shade.
  - e. produces less hazardous fumes.

## Agricultural Construction

---

**Complete the following short answer questions.**

5. What are three advantages of air carbon-arc cutting?
  - a.
  - b.
  - c.
6. List six safety precautions to follow when using air carbon-arc cutting.
  - a.
  - b.
  - c.
  - d.
  - e.
  - f.
7. What are three ways to avoid hazardous fumes from the air carbon-arc process?
  - a.
  - b.
  - c.
8. What are three maintenance considerations for air carbon-arc equipment?
  - a.
  - b.
  - c.

9. What are four advantages of plasma-arc cutting?
- a.
  - b.
  - c.
  - d.
10. What are three types of metal that can be cut with plasma-arc?
- a.
  - b.
  - c.
11. What are six safety precautions to follow when plasma-arc cutting?
- a.
  - b.
  - c.
  - d.
  - e.
  - f.
12. What are three ways to reduce noise during plasma-arc cutting?
- a.
  - b.
  - c.

## Agricultural Construction

---

13. What are five ways to maintain equipment used during plasma-arc cutting?

- a.
- b.
- c.
- d.
- e.

14. How is plasma created?

15. When working on a machine with an amperage of 400-800, what is the recommended lens shade number for plasma-arc cutting?

**SCHEMATIC OF AIR CARBON-ARC GOUGING**

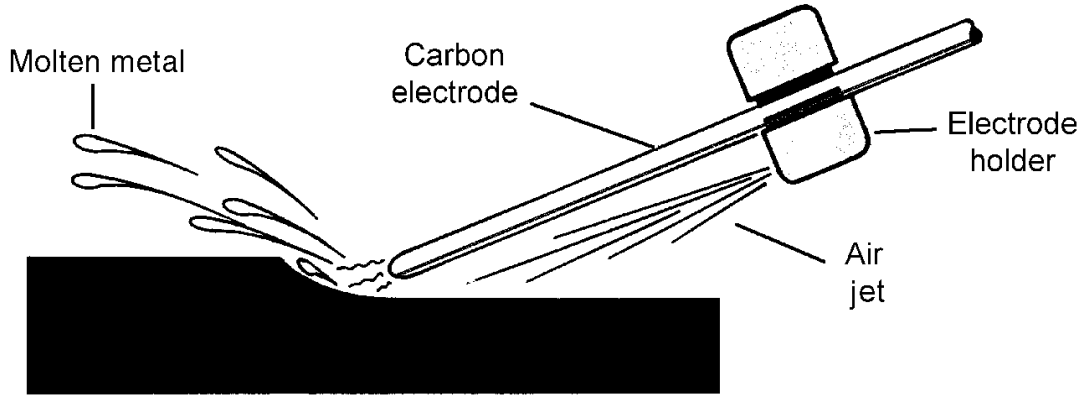



**SCHEMATIC OF PLASMA-ARC CUTTING**

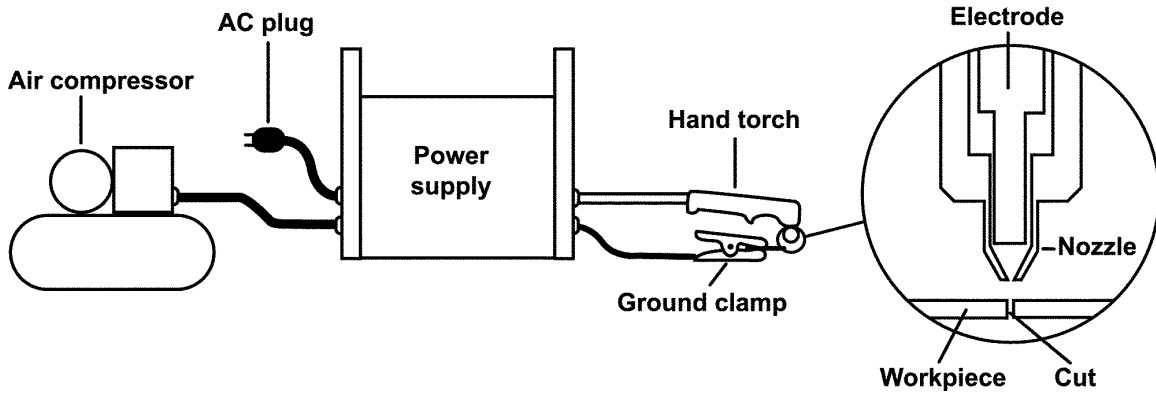





## UNIT I - OXY-GAS AND OTHER CUTTING/ WELDING PROCESSES

### Demonstration Sheet 1.1: Air Carbon-Arc Cutting

#### Objective

At the completion of this demonstration, the student will be ready to begin the job sheet on cutting metal using the air carbon-arc cutting process.

#### Tools and Equipment Needed

1. Arc welding machine
2. Electrode lead
3. Ground lead with clamp
4. Air carbon-arc torch
5. Compressed air supply with regulator
6. Air hose
7. Chipping hammer
8. Equipment and supplies for cleaning metal
9. Protective clothing
10. Safety glasses\*
11. Welding helmet\*

\* CAUTION: Welding helmets and safety glasses must be worn by the operator and all students observing the demonstration. Safety practices should be followed at all times while in the shop area.

#### Materials Needed

1. Mild steel plate - size to be determined by the instructor
2. Air carbon-arc cutting electrode

#### Precutting Procedure

1. Clean all dirt, grease, and foreign materials from the surface of the metal.
2. Remove all flammable materials from the work area. Provide proper ventilation.
3. Expose the air and power connections by pushing back the insulated boot on the air carbon-arc torch.
4. Attach the torch to the power assembly. The air hose should be attached to the air hose connection. Replace the insulated boot over the air and power connections.
5. Attach the regulator to the compressed air supply and attach the air hose to the regulator.

## Agricultural Construction

---

\* CAUTION: Do not use oxygen as the compressed air supply because it is flammable.

6. Adjust the regulator to 60-100 psi. Spray air on a piece of metal to make sure the air is free of moisture and abrasive particles. If moisture collects on the metal or if abrasive particles are present, the compressed air supply should be checked.
7. Insert the electrode into the jaws of the torch with approximately 6" of electrode extending beyond the torch. Note: Burning the electrode to less than 2" in length can damage the torch.
8. Attach the clamp on the ground lead to the workpiece.
9. Set the arc welding machine to DC, reverse polarity. Adjust the amperage according to the electrode diameter.

### Cutting Procedure

1. Position the air jets on the torch between the electrode and the base metal.
2. Position the electrode at a 90-degree work angle and a 45-degree travel angle, opposite the direction of travel.
3. Turn the arc welding machine on.
4. Turn on the air jet with the air valve located on the torch. Make sure the welding helmet is lowered over the face.
5. Strike an arc and move the electrode in the direction of the cut, just as the arc exits the back side of the base metal. Make sure to keep the torch at a consistent angle and speed.
6. Finish the cut. Turn off the air jet by using the air valve on the torch. Place the torch in a safe position where the electrode will not come in contact with metal.

### Postcutting Procedure

1. Turn off the air supply and the arc welding machine.
2. Remove the air carbon-arc torch from the air hose.
3. Clean the work area.
4. When the metal is cool, chip slag and remove other residue from the cut.
5. Examine the cut for accuracy and appearance.
6. Assign JS 1.1 to be completed by students.

## UNIT I - OXY-GAS AND OTHER CUTTING/ WELDING PROCESSES

### Demonstration Sheet 1.2: Plasma-Arc Cutting

#### Objective

At the completion of this demonstration, the student will be ready to begin the job sheet on cutting metal using the plasma-arc cutting process.

#### Tools and Equipment Needed

1. Plasma power sources
2. Plasma torch and leads
3. Gases (as required by manufacturer)
4. Safety glasses\*
5. Welding helmet\*
6. Protective clothing
7. Straightedge

\*CAUTION: Welding helmets and safety glasses must be worn by all students observing the demonstration. Safety practices should be followed at all times while in the shop area.

#### Materials Needed

1. Piece of ferrous or nonferrous metal
2. Electrode

#### Precutting Procedure

1. Connect the torch to the power source.
2. Attach gas lines from the machine to the required cylinder or gas line. (Some machines operate on compressed air while others require gases stored in cylinders or bulk storage tanks.)
3. Set the power level on the machine to the required level.
4. Set the regulators or flow meter to the required amount.
5. If applicable, attach the torch coolant lines to water or radiator sources.
6. Using a straightedge, mark lines on the metal to be cut.
7. Align the straightedge with the mark so that the plasma torch will cut evenly along the line.

## **Cutting Procedure**

1. Start the machine and move along the side of the straightedge for the complete length of the desired cut.
2. Stop the cutting action and position the tip of the plasma torch in a safe direction.

## **Postcutting Procedure**

1. Turn the machine off.
2. Check the cut for slag, burn-through, and accuracy.
3. Assign JS 1.2 to be completed by students.

## UNIT I - OXY-GAS AND OTHER CUTTING/ WELDING PROCESSES

### Job Sheet 1.1: Air Carbon-Arc Cutting

#### Objective

At the completion of this job sheet, the student will be able to cut metal using the air carbon-arc cutting processes.

#### Tools and Equipment Needed

1. Arc welding machine
2. Electrode lead
3. Ground lead with clamp
4. Air carbon-arc torch
5. Compressed air supply with regulator
6. Air hose
7. Chipping hammer
8. Equipment and supplies for cleaning metal
9. Protective clothing
10. Safety glasses\*
11. Welding helmet\*

\* CAUTION: Welding helmets and safety glasses must be worn by the operator and all students observing the demonstration. Safety practices should be followed at all times while in the shop area.

#### Materials Needed

1. Mild steel plate - size to be determined by the instructor
2. Air carbon-arc cutting electrode

#### Precutting Procedure

1. Clean all dirt, grease, and foreign materials from the surface of the metal.
2. Remove all flammable materials from the work area. Provide proper ventilation.
3. Expose the air and power connections by pushing back the insulated boot on the air carbon-arc torch. See Figure 1.1.

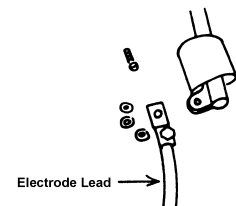

Figure 1.1

## Agricultural Construction

4. Attach the torch to the power assembly. The air hose should be attached to the air hose connection. Replace the insulated boot over the air and power connections. See Figure 1.2.
5. Attach the regulator to the compressed air supply and attach the air hose to the regulator. **CAUTION:** Do not use oxygen as the compressed air supply because it is flammable.
6. Adjust the regulator to 60-100 psi. Spray air on a piece of metal to make sure the air is free of moisture and abrasive particles. If moisture collects on the metal or if abrasive particles are present, the compressed air supply should be checked.
7. Insert the electrode into the jaws of the torch with approximately 6" of electrode extending beyond the torch. Note: Burning the electrode to less than 2" in length can damage the torch.
8. Attach the clamp on the ground lead to the workpiece.
9. Set the arc welding machine to DC, reverse polarity. Adjust the amperage according to the electrode diameter.

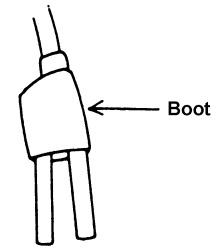

Figure 1.2

### Cutting Procedure

1. Position the air jets on the torch between the electrode and the base metal.
2. Position the electrode at a 90-degree work angle and a 45-degree travel angle, opposite the direction of travel. See Figures 1.3 and 1.4.
3. Turn the arc welding machine on.
4. Turn on the air jet with the air valve located on the torch. Make sure the welding helmet is lowered over the face.
5. Strike an arc and move the electrode in the direction of the cut, just as the arc exits the back side of the base metal. Make sure to keep the torch at a consistent angle and speed.
6. Finish the cut. Turn off the air jet by using the air valve on the torch. Place the torch in a safe position where the electrode will not come in contact with metal.

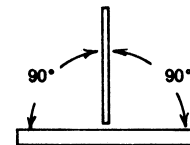

Figure 1.3

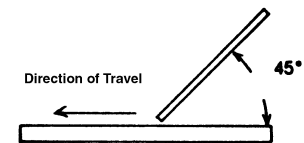

Figure 1.4

## Postcutting Procedure

1. Turn off the air supply and the arc welding machine.
2. Remove the air carbon-arc torch from the air hose.
3. Clean the work area.
4. When the metal is cool, chip slag and remove other residue from the cut.
5. Examine the cut for accuracy and appearance.
6. Give the cut to the instructor for grading.





## UNIT I - OXY-GAS AND OTHER CUTTING/ WELDING PROCESSES

### Job Sheet 1.2: Plasma-Arc Cutting

#### Objective

At the completion of this job sheet, the student will be able to cut metal using the plasma-arc cutting process.

#### Tools and Equipment Needed

1. Plasma power sources
2. Plasma torch and leads
3. Gases (as required by manufacturer)
4. Safety glasses\*
5. Welding helmet\*
6. Protective clothing
7. Straightedge

\* CAUTION: Welding helmet and safety glasses must be worn by all students performing the job sheet. Safety practices should be followed at all times while in the shop area.

#### Materials Needed

1. Piece of ferrous or nonferrous metal

#### Precutting Procedure

1. Connect the torch to the power source.
2. Attach the gas lines from the machine to the required cylinder or gas line. (Some machines operate on compressed air while others require gases stored in cylinders or bulk storage tanks.)
3. Set the power level on the machine to the required level.
4. Set the regulators or flow meter to the required amount.
5. If applicable, attach the torch coolant lines to water or radiator sources.
6. Using a straightedge, mark several lines on the metal to be cut.
7. Align the straightedge with the mark so that the plasma torch will cut evenly along the line.

# Agricultural Construction

## Cutting Procedure

1. Start the machine and move along the side of the straightedge for the complete length of the desired cut, as shown in Figure 1.1.
2. Stop the cutting action and position the tip of the plasma torch in a safe direction. Repeat the cutting procedure for each line.

## Postcutting Procedure

1. Turn the machine off.
2. Examine the cut for accuracy and appearance.
3. Give the cut to the instructor for grading.
4. Clean the work area.

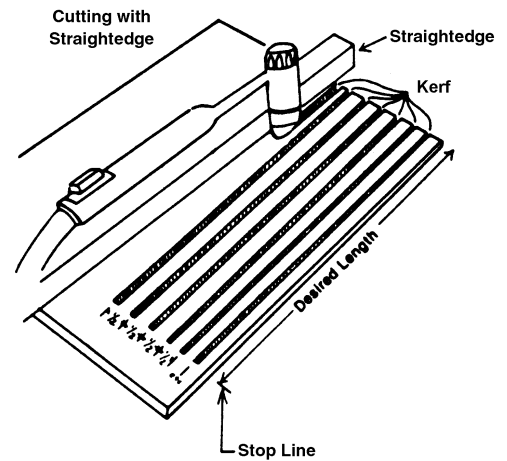

Figure 1.1

# UNIT II - ARC WELDING

## Gas Metal Arc Welding (GMAW)/MIG

### Objective

The student will be able to make a series of welds in a variety of positions using GMAW or MIG welding.

### Study Questions

1. What are the principles of GMAW?
2. What are the primary ways that metal is transferred using GMAW?
3. What are the advantages and limitations of GMAW?
4. What safety and maintenance precautions need to be followed for GMAW?
5. What are the steps for GMAW setup?
6. What are the steps for GMAW shutdown?

### References

1. Giachino, J.W.; W. Weeks. Welding Skills Alsip, NY: American Technical Publishers, 1985.
2. Minnick, William H. Gas Metal Arc Welding Handbook Tinley Park, IL: Goodheart-Willcox Company, Inc. 2000.
3. Demonstration Sheets
  - a) DS 2.1: Prewelding and Postwelding Procedures for GMAW
  - b) DS 2.2: Welds in the Flat Position
  - c) DS 2.3: Welds in the Horizontal Position
  - d) DS 2.4: Welds in the Vertical Position
  - e) DS 2.5: Welds in the Overhead Position
4. Job Sheets
  - a) JS 2.1: Prewelding and Postwelding Procedures for GMAW
  - b) JS 2.2: Welds in the Flat Position
  - c) JS 2.3: Welds in the Horizontal Position
  - d) JS 2.4: Welds in the Vertical Position
  - e) JS 2.5: Welds in the Overhead Position

## UNIT II - ARC WELDING

### Gas Metal Arc Welding (GMAW)/MIG

#### TEACHING PROCEDURES

##### A. Review

Review the previous lesson on shielded metal arc welding. Emphasize its application for agricultural uses.

##### B. Motivation

Ask students what type of farm equipment could be created or repaired using GMAW. Show them one or two pieces. Why is this method preferable to SMAW?

##### C. Assignment

##### D. Supervised study

##### E. Discussion

Gas metal arc welding (GMAW) is also known as metal inert gas (MIG) welding in the industry. GMAW is the more apt name because the shielding gas is not always inert. Given the two popular names for this type of arc welding, how do students think a weld is made?

#### 1. What are the principles of GMAW?

- a) An electric arc between a continuously fed metal electrode (wire) and the base metal produces heat.
- b) A gas, usually argon, helium, or carbon dioxide, shields the electric arc.
- c) The welder performs the following procedures:
  - 1) Selects electrode size
  - 2) Sets desired voltage
  - 3) Adjusts gas flow
  - 4) Adjusts rate of electrode feed
  - 5) Controls gun movement
  - 6) Control selectrode extension.
- d) One machine can regulate the power supply and rate of electrode feed and gas volume, or separate machines can run a specific aspect of the weld. The following equipment is required for GMAW.
  - 1) A power source
    - a. A constant voltage machine sets the arc voltage by establishing the output voltage.
    - b. A constant current power supply sets the arc by an automatic electrode feed rate.
  - 2) DC rectifier or motor generator

- 3) Shielding gas supply
- 4) An electrode-feeding device to supply electrodes continuously
- 5) Welding gun to carry wire, electricity, and gas to the arc, with a trigger switch for controlling the electrode feed and gas flow

The way the filler comes in contact with the workpiece is called the process mode. Four process modes are listed below. Ask the students how many ways they think this could take place.

### **2. What are the primary ways that metal is transferred using GMAW?**

- a) Short circuiting-arc or short arc
  - 1) The electrode is fed until it touches the workpiece.
  - 2) The circuit shorts and burns off the tip of the electrode.
  - 3) Melted metal is deposited into the weld joint.
- b) Globular
  - 1) The electrode burns off above or in contact with the workpiece.
  - 2) The molten metal falls in an erratic pattern around the weld site.
- c) Spray arc
  - 1) The electrode is melted above the workpiece.
  - 2) The metal drops into the joint.
- d) Pulse-spray arc or spray-arc pulse
  - 1) The electrode is melted above the workpiece.
  - 2) The melted metal is released with a pulsing action.
  - 3) The filler is dropped at a controlled time in the weld cycle.
  - 4) This is the most popular method because it causes the least splatter.

GMAW is useful for a number of jobs. Ask students to consider the advantages and limitations of the GMAW process. List them on the board and discuss them.

### **3. What are the advantages and limitations of GMAW?**

- a) Advantages
  - 1) Easy type of welding to learn
  - 2) Produces high-quality welds because of better heat control at weld zone
  - 3) Adaptable for a variety of thickness of ferrous and non ferrous metals
  - 4) Easily adaptable to either automatic or semi-automatic operations
  - 5) Very little cleanup necessary; not much slag formed
  - 6) A faster process than both tungsten inert gas (TIG) and SMAW
- b) Limitations
  - 1) Requires more equipment than SMAW
  - 2) Expensive because of equipment requirements
  - 3) Not as adaptable as SMAW because weld gun must be close to work
  - 4) Easily contaminated by windy conditions

## Agricultural Construction

---

Show students a GMAW machine. How does the GMAW machine compare to the shielded metal arc welder?

### 4. What safety and maintenance precautions need to be followed for GMAW?

- a) Electrical safety and maintenance
  - 1) The welder must have an earth ground.
  - 2) All electrical connections must be tight, clean, and dry.
  - 3) Keep work area, equipment, and clothing dry.
  - 4) Never dip a gun in water to cool it.
  - 5) In multiple-machine operations do not touch hot parts of gun because open-circuit voltages are increased and can cause severe shock.
  - 6) Disconnect and lock all electrical power sources before performing work on any electrical equipment.
  - 7) Do not connect cables to building framework.
  - 8) When working in high places, check area for electrical hazards because a shock could cause a fall.
- b) Safety and maintenance with cables and hoses
  - 1) Never drag cables or hoses.
  - 2) Never pull on cable to force it over an obstruction.
  - 3) Use only clean rags to clean cables and hoses. Never use gas or oily rags to clean cables or hoses.
  - 4) Keep cables and hoses free of kinks at all times.
  - 5) Do not drape welding cables over any type of gas cylinder.
- c) Safety and maintenance with gas cylinders
  - 1) Always store cylinders in an upright position in a well-ventilated or outdoor area.
  - 2) Secure cylinders upright with chains or straps.
  - 3) Do not roll other objects on horizontal cylinders.
  - 4) Keep the protective valve in place except when cylinder is in use.
  - 5) To clean the valve and check outlet threads, crack the cylinder open briefly.
  - 6) Regulator should register no pressure when first attached. Do not stand in front of gauges when opening a cylinder.
  - 7) Never strike an arc on a gas cylinder.
- d) Safety with electrode wire
  - 1) Always wear safety glasses when handling wire.
  - 2) Always keep wire clean and dry.
  - 3) Position coils close to reel before lifting and use the legs to lift coil, not the back.
  - 4) Never look into a gun while feeding wire through it.
  - 5) Never point the gun at anyone.
  - 6) Never place a finger over a contact tip to determine if wire is feeding.
- e) Personal safety equipment
  - 1) Wear welding hood or helmet with shaded lens to protect head from flying sparks and eyes from ultraviolet and infrared radiation.
    - a. Lens shade requirements are based on wire size, amperage range, and base metal properties.

- b. Select lens shade according to lens manufacturer's selection card. Never select less than a No. 11 lens shade for GMAW.
- 2) Wear gloves, long sleeved shirt, long pants without cuffs, and work boots to avoid radiation and hot metal burns.
  - a. Wear a leather jacket and apron for additional protection.
  - b. Clothing should be dark and made of cotton or wool. Avoid synthetic clothing. No flammable materials should be carried in the pockets of clothing.
- 3) Work stations and work areas should be shielded to prevent nearby workers or visitors from an arc flash injury.
- f) Environmental safety
  - 1) Equip every work station with a ventilation or exhaust system capable of safely removing dangerous fumes and vapors.
  - 2) Welders should wear respirators when welding in confined areas. The respirator should be the air-supplied type or a self-contained breathing apparatus.
  - 3) Argon is heavier than air and will quickly displace oxygen. Heed precautions, especially in confined areas.
  - 4) Wear ear plugs or earmuffs in areas subject to high noise levels, especially those levels that are continuous.
  - 5) Provide lighting that is bright enough to provide good visibility free of glare. Poorly lit areas contribute to eye fatigue, irritation, and poor work.

It is necessary to know how to start and shut down GMAW equipment. Ask students why proper setup is necessary. What problems may result with missed steps?

### **5. What are the steps for GMAW setup?**

- a) Check the power cable connections for reverse polarity.
- b) Connect gun to the medium slope welding terminal.
- c) Connect ground cable to the negative terminal.
- d) Connect ground clamp to either work or work table.
- e) Start power source: welding machine.
- f) Switch wire feeder to the "on" position.
- g) Set the wire feed speed control on zero.
- h) Check gas shielding supply system.
- i) Open gas cylinder outlet valve.
- j) Open flow meter valve slowly and squeeze the gun trigger simultaneously.
- j) Adjust the gas flow rate as desired. See instructions for specific machine and release the gun trigger.
- k) Set wire feed speed to intermediate setting. Wire speed determines welding current in constant voltage systems.
- l) Control the electrode stickout distance appropriately for each process. Stickout is the distance from the tip of the electrode to the surface of the workpiece.
- m) Adjust welding current as desired.
- n) To stop welding, release the gun trigger and withdraw from the work.

## Agricultural Construction

---

Performing the correct shutdown procedure is important for the user's safety and for the life of the equipment. Ask students what steps should be included in shutdown. Use DS 5.1 and JS 5.1

### 6. What are the steps for GMAW shutdown?

- a) Close gas outlet valve at the top of the gas cylinder.
- b) Close gun trigger with wire feed speedcontrol on zero to bleed gas line or use the purge button.
- c) Close gas flow meter valve so it is finger tight.
- d) Turn off wire feed switch.
- e) Turn off welding machine.
- f) Clean the work area.

### F. Other Activities

1. Determine when the purchase of a GMAW machine is justified for typical farm shop work. Determine the break-even point.
2. Put together a safety checklist card for GMAW equipment.

### G. Conclusion

Gas metal arc welding has many applications on and off the farm. It involves a continuous rod, a shielding gas, and the heat of electricity for easy and excellent welds.

### H. Competency

Weld in all positions with MIG welder (gas metal arc welding).

- a. Weld in flat position using E-70S-3 & E-71S-3
- b. Weld in vertical position using E-70S-3 & E-71S-3
- c. Weld in horizontal position using E-70S-3 & E-71S-3
- d. Weld in overhead position using E-70S-3 & E-71S-3

### I. Answers to Evaluation

1. d
2. d
3. d
4. c
5. Four of the following: easy type of welding to learn; produces high quality welds because of better heat control at weld zone; adaptable for a variety of thickness of ferrous and non ferrous metals; easily adaptable to either automatic or semi-automatic operations; very little cleanup necessary - not much slag formed; faster process than both tungsten inert gas (TIG) and SMAW.
6. Three of the following: requires more equipment than SMAW's, expensive because of equipment requirements, not as adaptable as SMAW because weld gun must be close to work, is easily contaminated by windy conditions



7. Also called metal inert gas welding, GMAW is the use of an electric arc, shielded by gas (usually argon, helium or carbon dioxide) to heat and melt a continuous feed of wire/electrode. The melted wire becomes the filler for the weld.
8. d
9. e
10. c
11. b
12. a and f
13. f
14. a
15. e
16. b
17. d and f



## UNIT II - ARC WELDING

### Gas Metal Arc Welding (GMAW)/MIG

Name \_\_\_\_\_

Date \_\_\_\_\_

#### Evaluation

**Multiple Choice. Circle the letter that corresponds to the best answer.**

1. What is the most popular GMAW process?
  - a. Globular
  - b. Spray arc
  - c. Short-circuit
  - d. Pulse-spray
  
2. What is the minimum lens shade number for gas metal arc welding?
  - a. 2
  - b. 4
  - c. 7
  - d. 11
  
3. Which of the following is a step for setting up GMAW?
  - a. Rolling gas cylinders across the shop.
  - b. Disconnect and lock power before repairing equipment.
  - c. Clean work area.
  - d. Check the power cable connections for reverse polarity.
  
4. Which of the following is a step for shutting down GMAW?
  - a. Strike an arc on a gas cylinder.
  - b. Adjust gas flow rate.
  - c. Clean work area.
  - d. Connect ground clamp to either work or work table.

**Complete the following short-answer questions.**

5. What are four advantages of GMAW?
  - a.
  - b.

## Agricultural Construction

---

- c.
  - d.
6. What are three limitations of GMAW?
- a.
  - b.
  - c.
7. What is Gas Metal Arc Welding?

**Match the statement on the left with the category of safety on the right. Write the letter in the space provided. Letters may be used more than once.**

- |   |                                 |
|---|---------------------------------|
| ___ 8. Keep fingers away from tip of wire gun                 | A. Environmental safety         |
| ___ 9. Store cylinders upright                                | B. Electrical safety            |
| ___ 10. Use clean rags to keep hoses free of grime            | C. Safety with cables and hoses |
| ___ 11. Have an earth ground                                  | D. Safety with electrodes       |
| ___ 12. Earmuffs and earplugs reduce noise pollution          | E. Safety with gas              |
| ___ 13. Clothing made of natural fibers only                  | F. Personal safety equipment    |
| ___ 14. Lighting that provides good visibility, free of glare |                                 |
| ___ 15. Crack a cylinder to clean a valve                     |                                 |
| ___ 16. Keep connections dry, clean, and tight                |                                 |
| ___ 17. Always wear safety glasses when handling wire         |                                 |

## UNIT II - ARC WELDING

### Demonstration Sheet 2.1: Prewelding and Postwelding Procedures for GMAW

#### Objective

At the completion of this demonstration, the student will be prepared to begin the job sheet in setting up, adjusting, and shutting down the gas metal arc welding machine.

#### Tools and Equipment Needed

1. GMAW welder
2. Protective clothing
3. Safety goggles\*
4. Pliers
5. Helmet\*

\* **CAUTION:** The welder and all students observing this demonstration must wear the proper eye protection. Safety precautions should be observed while in the shop area.

#### Materials Needed

1. E-70S-3 & E-71S-3 wire - .035 inch diameter
2. Mild steel plates - size to be determined by the instructor

#### Prewelding Procedure

1. Set the machine to Direct Current Reverse Polarity. Straight polarity should be used only when a shallow penetration is needed.
2. Plug the welding gun cable into the medium slope terminal located on the welding machine.
3. Plug the ground cable into the negative terminal on the welding machine.
4. Connect the ground cable to the table or metal to be welded.
5. Turn the welding machine power switch to "on."
6. Turn the wire feed control mechanism power switch to "on."
7. Adjust the wire feed speed to zero while setting gas flow, amperage, and voltage. This will prevent wasting wire while making adjustments to gas flow.
8. Open the cylinder valve on top of the gas tank.
9. Gas flow should be adjusted to 20 to 25 cubic feet/hour (cfh). Slowly open the flow meter valve located at the top of the cylinder to adjust the amount of shielding gas being delivered to the weld area. The trigger on the welding gun should be depressed while turning the valve on the flow meter to obtain a reading.
10. Voltage should be adjusted to 19 to 21.

## Agricultural Construction

---

11. Adjust the wire feed control to provide 100 to 120 amps. A trial setting of 5 should be used for wire feed speed and adjusted accordingly in a constant voltage machine.
  - a) In a machine that provides constant current, the amperage is adjusted through the voltage setting. Check the manufacturer's manual to determine if your machine provides constant current or constant voltage.
  - b) Run a practice bead to check if the correct amperage is being received.
  - c) To strike an arc, squeeze the trigger on the gun at the same time that the tip of the wire touches the metal to be welded. The assistance of another person will be required to take a reading of the amperage while you are welding.
  - d) You should also check for the correct voltage at this time. Increasing the wire speed will increase the amount of current provided for welding. Decreasing the wire speed will decrease the amount of current.
  - e) When running a test bead, the arc should make a sizzling sound if the proper amount of shielding gas is being used.
12. Adjust the wire stickout to 1/4 to 3/8 inches. The length of stickout is measured from the welding tip to the surface of the metal to be welded.
13. Explain any additional features of your gas metal arc welding machine.

### Postwelding Procedure

1. When welding is complete, shut off the valve on the top of the gas cylinder.
2. Bleed the gas from the line by depressing the trigger on the welding gun. If the machine you are using has a button, pressing it will also bleed the gas from the line.
3. Close the flow meter valve on the top of the gas cylinder to finger tight. This prevents damage to the flow meter the next time the cylinder valve is opened.
4. Turn off the wire feed speed switch.
5. Turn off the power switch on the welding machine.
6. Return cables to the proper storage position.
7. Clean the work area of scrap metal.

## UNIT II - ARC WELDING

### Demonstration Sheet 2.2: Welds in the Flat Position

#### Objective

At the completion of the demonstration, the student will be prepared to begin the job sheet in performing butt, lap, and T-fillet welds in the flat position using a GMAW welder.

#### Tools and Equipment Needed

1. GMAW welder
2. Protective clothing
3. Safety goggles\*
4. Pliers
5. Helmet\*

\* **CAUTION:** The welder and all students observing this demonstration must wear the proper eye protection. Safety precautions must be observed while in the shop area.

#### Materials Needed

1. E-70S-3 & E-71S-3 wire - .035 inch diameter
2. Mild steel plates - size to be determined by the instructor

#### Prewelding Procedure

Refer to DS 2.1 for prewelding procedures needed to prepare for welding in a flat position.

#### Welding Procedure

##### BUTT JOINT

1. Lower the helmet. Before striking an arc, tell persons in the area to cover themselves. Tack weld two pieces of mild steel together to form a butt joint. If the metal is thicker than 1/8 inch, the edges of the joint should be beveled to increase penetration. A space, no more than 1/8 inch, should be left between the metal plates to increase penetration of the weld.
2. Position the metal so that the joint to be welded is in flat position.
3. The electrode should be positioned at a 90° work angle and a 25° to 30° drag angle to perform the weld.
4. Lower the helmet. Strike the arc and adjust the length of wire stickout to provide the desired penetration. Lengthening wire stickout will decrease penetration, whereas decreasing wire stickout will increase the amount of penetration.
5. Maintain the proper electrode angle while using a slight weaving motion to produce the desired weld.
6. Examine the weld for penetration and bead appearance.

## Agricultural Construction

---

7. Discuss possible improvements with students and how these improvements might be accomplished.

### LAP JOINT

1. Lower the helmet. Before striking an arc, tell persons in the area to cover themselves. Tack weld two pieces of mild steel together to form a lap joint. If the metal is thicker than 1/8 inch, the edges of the joint should be beveled to increase penetration.
2. Position the metal so that the joint to be welded is in the flat position.
3. The electrode should be positioned at a 90° work angle and a 25° to 30° drag angle to perform the weld.
4. Lower the helmet. Strike the arc and adjust wire stickout to provide the desired penetration. Lengthening wire stickout will decrease penetration, while decreasing wire stickout will increase the amount of penetration received.
5. Maintain the proper electrode angle while using a slight weaving motion to produce the desired weld.
6. Examine the weld for penetration and bead appearance.
7. Discuss possible improvements with students and how these improvements might be accomplished.

### T-FILLET JOINT

1. Lower the helmet. Before striking an arc, tell persons in the area to cover themselves. Tack weld two pieces of mild steel together to form a T-joint. If the metal exceeds 1/8 inch in thickness, the edge of the vertical plate should be beveled to increase penetration.
2. Position the metal so that the joint to be welded is in the flat position.
3. The electrode should be positioned at a 45° work angle and a 10° drag angle to perform the weld.
4. Lower the helmet. Strike the arc and adjust wire stickout to provide the desired penetration. Lengthening wire stickout will decrease penetration, whereas decreasing wire stickout will increase the amount of penetration.
5. Maintain the proper electrode angle while using a slight weaving motion to produce the desired weld.
6. Examine the weld for penetration and bead appearance.
7. Discuss possible improvements in the welds with the students and how these improvements might be accomplished.

### Postwelding Procedure

Refer to DS 2.1 for correct postwelding procedures.



## UNIT II -ARC WELDING

### Demonstration Sheet 2.3: Welds in the Horizontal Position

#### Objective

At the completion of this demonstration, the student will be ready to begin the job sheet in performing butt and T-fillet welds in the horizontal position using a GMAW welder.

#### Tools and Equipment Needed

1. GMAW welder
2. Protective clothing
3. Safety goggles\*
4. Pliers
5. Helmet\*

\* **CAUTION:** The welder and all students observing this demonstration must wear proper eye protection. Safety precautions should be observed while working in the shop area.

#### Materials Needed

1. E-70S-3 & E-71S-3 wire - .035 inch diameter
2. Mild steel plates - size to be determined by the instructor

#### Prewelding Procedure

Refer to Shop Demonstration 2.1 for prewelding procedures needed to prepare for horizontal position welding.

#### Welding Procedure

##### BUTT JOINT

1. Lower the helmet. Before striking an arc, tell persons in the area to cover themselves. Tack weld two pieces of mild steel together to form a butt joint. If the metal is thicker than 1/8 inch, the edges of the joint should be beveled to increase penetration. A space, no more than 1/8 inch, should be left between the metal plates to increase penetration of the weld.
2. Position the metal so that the joint to be welded is in the horizontal position.
3. The electrode should be positioned at an 85° work angle and a 5° drag angle to perform the weld.
4. Lower the helmet. Strike the arc and adjust wire stickout to provide the desired penetration. Lengthening wire stickout will decrease penetration, whereas decreasing wire stickout will increase the amount of penetration.
5. Maintain the proper electrode angle while using a slight weaving motion to produce the desired weld.
6. Examine the weld for penetration and bead appearance.

## Agricultural Construction

---

7. Discuss possible improvements with students and how these improvements might be accomplished.

### T-FILLET JOINT

1. Lower the helmet. Before striking an arc, tell persons in the area to cover themselves. Tack weld two pieces of mild steel together to form a T-joint.
2. Position the metal so that the joint to be welded is in the flat position.
3. The electrode should be positioned at a 45° work angle and a 10° to 15° drag angle to perform the weld.
4. Lower the helmet. Strike an arc and adjust wire stickout to provide the desired penetration. Lengthening wire stickout will decrease penetration, whereas decreasing wire stickout will increase the amount of penetration.
5. Maintain the proper electrode angle while using a slight weaving motion to produce the desired weld.
6. Examine the weld for penetration and bead appearance.
7. Discuss with students possible improvements that could be made and how these improvements might be accomplished.

### Postwelding Procedure

Refer to DS 2.1 for correct postwelding procedures.

## UNIT II -ARC WELDING

### Demonstration Sheet 2.4: Welds in the Vertical Position

#### Objective

At the completion of this demonstration, the student will be ready to begin the job sheet in performing butt, lap, and T-fillet welds in the vertical position using a GMAW welder.

#### Tools and Equipment Needed

1. GMAW welder
2. Protective clothing
3. Safety goggles\*
4. Pliers
5. Helmet\*

\* **CAUTION:** The welder and all students observing this demonstration must wear proper eye protection. Safety precautions must be observed while in the shop area.

#### Materials Needed

1. E-70S-3 & E-71S-3
2. Mild steel plates - size to be determined by the instructor

#### Prewelding Procedure

Refer to DS 2.1 for prewelding procedures needed to prepare for vertical position welding.

#### Welding Procedure

##### BUTT JOINT - VERTICAL UP

1. Lower the helmet. Before striking an arc, tell persons in the area to cover themselves. Tack weld pieces of mild steel together to form a butt joint. If the metal is thicker than 1/8 inch, the edges of the joint should be beveled to increase penetration. A space, no more than 1/8 inch, should be left between the metal plates to increase penetration of the weld.
2. Position the metal so that the joint to be welded is in the vertical position.
3. The electrode should be positioned at a 90° work angle and a 10° to 15° push angle to perform the weld.
4. Lower the helmet. Strike an arc and adjust wire stickout to provide the desired penetration. Lengthening wire stickout will decrease penetration, whereas decreasing wire stickout will increase the amount of penetration.
5. Maintain the proper electrode angle while using a slight weaving motion to produce the desired weld.
6. Examine the weld for penetration and bead appearance.

## Agricultural Construction

---

7. Discuss possible improvements with students and how these improvements might be accomplished.

### BUTT JOINT - VERTICAL DOWN

1. Lower the helmet. Before striking an arc, tell persons in the area to cover themselves. Tack weld two pieces of mild steel together to form a butt joint. The vertical-down position should only be used when welding thin gauge metal since the speed of welding required will not allow for adequate penetration of thicker metals.
2. Position the metal so that the joint to be welded is in the vertical position.
3. The electrode should be positioned at a 90° work angle and a 10° to 15° drag angle to perform the weld.
4. Lower the helmet. Strike an arc and adjust the wire stickout to provide the desired penetration. Lengthening wire stickout will decrease penetration, whereas decreasing wire stickout will increase the amount of penetration.
5. Maintain the proper electrode angle while using a slight weaving motion to produce the desired weld. A faster welding speed should be used than when making a vertical up weld. Welding too slowly will result in loss of control of the weld puddle and will increase the chance of burnthrough. Welding too quickly will make it difficult to maintain a stable arc, resulting in poor penetration.
6. Examine the weld for penetration and bead appearance.
7. Discuss possible improvements with students and how these improvements might be accomplished.

### LAP JOINT - VERTICAL UP

1. Lower the helmet. Before striking an arc, tell persons in the area to cover themselves. Tack weld two pieces of mild steel together to form a lap joint.
2. Position the metal so that the joint to be welded is in the vertical position.
3. The electrode should be positioned at a 45° work angle and a 10° to 15° push angle to perform the weld.
4. Lower the helmet. Strike an arc by squeezing the trigger on the gun at the same time that the tip of the wire touches the metal to be welded. Adjust the length of wire stickout to provide the desired penetration. Lengthening wire stickout will decrease penetration, whereas decreasing wire stickout will increase the amount of penetration.
5. Maintain the proper electrode angle while using a slight weaving motion to produce the desired weld.
6. Examine the weld for penetration and bead appearance.
7. Discuss possible improvements with students and how these improvements might be accomplished.

### LAP JOINT - VERTICAL DOWN

1. Lower the helmet. Tack weld two pieces of mild steel together to form a lap joint. “Cover” should be said before striking the arc. The vertical-down position should only be used when welding thin gauge metal, since the speed of welding required will not allow for penetration of thicker metals.
2. Position the metal so that the joint to be welded is in the vertical position.
3. The electrode should be positioned at a 45° work angle and a 10° to 15° drag angle to perform the weld.
4. Lower the helmet. Strike the arc and adjust the wire stickout to provide the desired penetration. Lengthening wire stickout will decrease penetration, whereas decreasing wire stickout will increase the amount of penetration.

5. Maintain the proper electrode angle while using a slight weaving motion to produce the desired weld. A faster welding speed should be used than when making a vertical up weld. Welding too slowly will result in loss of control of the weld puddle and will increase the chance of burnthrough. Welding too quickly will make it difficult to maintain a stable arc, resulting in poor penetration.
6. Examine the weld for penetration and bead appearance.
7. Discuss possible improvements with students and how these improvements might be accomplished.

### T-FILLET JOINT - VERTICAL UP

1. Lower the helmet. Before striking an arc, tell persons in the area to cover themselves. Tack weld two pieces of mild steel together to form a T-joint.
2. Position the metal so that the joint to be welded is in the vertical position.
3. The electrode should be positioned at a 45° work angle and a 10° to 15° push angle to perform the weld.
4. Lower the helmet. Strike an arc and adjust the length of wire stickout to provide the desired penetration. Lengthening wire stickout will decrease penetration, whereas decreasing wire stickout will increase the amount of penetration.
5. Maintain the proper electrode angle while using a slight weaving motion to produce the desired weld.
6. Examine the weld for penetration and bead appearance.
7. Discuss with students possible improvements that could be made to the weld and how these improvements might be accomplished.

### T-FILLET JOINT - VERTICAL DOWN

1. Lower the helmet. Before striking an arc, tell persons in the area to cover themselves. Tack weld two pieces of mild steel together to form a T-joint. The vertical-down position should only be used when welding thin-gauge metal, because the speed of welding required will not allow for adequate penetration of thicker metals.
2. Position the metal so that the joint to be welded is in the vertical down position.
3. The electrode should be positioned at a 45° work angle and a 10° to 15° drag angle to perform the weld.
4. Lower the helmet. Strike an arc and adjust the wire stickout to provide the desired penetration. Lengthening wire stickout will decrease penetration, whereas decreasing wire stickout will increase the amount of penetration.
5. Maintain the proper electrode angle while using a slight weaving motion to produce the desired weld. A faster welding speed should be used than when making a vertical up weld. Welding too slowly will result in loss of control of the weld puddle and will increase the chance of burnthrough. Welding too quickly will make it difficult to maintain a stable arc, resulting in poor penetration.
6. Examine the weld for penetration and bead appearance.
7. Discuss possible improvements with students and how these improvements might be accomplished.

### Postwelding Procedure

Refer to DS 2.1 for correct postwelding procedures.



## UNIT II -ARC WELDING

### Demonstration Sheet 2.5: Welds in the Overhead Position

#### Objective

At the completion of this demonstration, the student will be ready to begin the job sheet in performing butt, lap, and T-fillet welds in the overhead position using a GMAW welder.

#### Tools and Equipment Needed

1. GMAW welder
2. Protective clothing
3. Safety goggles\*
4. Pliers
5. Helmet\*
6. Weld positioner

\* **CAUTION:** The welder and all students observing this demonstration must have the proper eye protection. Safety precautions should be observed while in the shop area.

#### Materials Needed

1. E-70S-3 & E-71S-3 wire - .035 inch diameter
2. Mild steel plates - size to be determined by the instructor

#### Prewelding Procedure

Refer to DS 2.1 for prewelding procedures needed to prepare for welding in the overhead position.

#### Welding Procedure

##### BUTT JOINT

1. Lower the helmet. Before striking an arc, tell persons in the area to cover themselves. Tack weld two pieces of mild steel together to form a butt joint. If the metal is thicker than 1/8 inch, the edges of the joint should be beveled to increase penetration. A space, no more than 1/8 inch, should be left between the metal plates to increase penetration of the weld.
2. Position the metal so that the joint to be welded is in the overhead position.
3. The electrode should be positioned at a 90° work angle and a 10° to 15° drag angle to perform the weld.
4. Lower the helmet. Strike an arc and adjust the length of wire stickout to provide the desired penetration. Lengthening wire stickout will decrease penetration, whereas decreasing wire stickout will increase the amount of penetration.
5. Maintain the proper electrode angle while using a slight weaving motion to produce the desired weld.
6. Examine the weld for penetration and bead appearance.

## Agricultural Construction

---

7. Discuss possible improvements with students and how these improvements might be accomplished.

### LAP JOINT

1. Lower the helmet. Before striking an arc, tell persons in the area to cover themselves. Tack weld two pieces of mild steel together to form a lap joint. If the metal is thicker than 1/8 inch, the edges of the joint should be beveled to increase penetration.
2. Position the metal so that the joint to be welded is in the overhead position.
3. The electrode should be positioned at a 45° work angle and a 10° to 15° drag angle to perform the weld.
4. Lower the helmet. Strike an arc and adjust the length of wire stickout to provide the desired penetration. Lengthening wire stickout will decrease penetration, whereas decreasing wire stickout will increase the amount of penetration.
5. Maintain the proper electrode angle while using a slight weaving motion to produce the desired weld.
6. Examine the weld for penetration and bead appearance.
7. Discuss possible improvements with students and how these improvements might be accomplished.

### T-FILLET JOINT

1. Lower the helmet. Before striking an arc, tell persons in the area to cover themselves. Tack weld pieces of mild steel together to form a T-joint.
2. Position the metal so that the joint to be welded is in the overhead position.
3. The electrode should be positioned at a 45° work angle and a 10° to 15° drag angle to perform the weld.
4. Lower the helmet. Strike an arc and adjust the length of wire stickout to provide the desired penetration. Lengthening wire stickout will decrease penetration, whereas decreasing wire stickout will increase the amount of penetration.
5. Maintain the proper electrode angle while using a slight weaving motion to produce the desired weld.
6. Examine the weld for penetration and bead appearance.
7. Discuss possible improvements with the students and how these improvements might be accomplished.

### Postwelding Procedure

Refer to DS 2.1 for correct postwelding procedures.



## UNIT II - ARC WELDING

### Job Sheet 2.1: Prewelding and Postwelding Procedures for GMAW

#### Objective

At the completion of this job sheet, the student will be able to set up, adjust, and shut down the machine used for gas metal arc welding.

#### Tools and Equipment Needed

1. GMAW welder
2. Protective clothing
3. Safety goggles\*
4. Pliers
5. Helmet\*

\* **CAUTION:** All students performing and observing this procedure must wear proper eye protection. Safety precautions must be observed while working in the shop.

#### Materials Needed

1. E-70S-3 & E-71S-3 wire - .035 inch diameter
2. Mild steel plates - size to be determined by the instructor

#### Prewelding Procedure

1. Set the machine to Direct Current Reverse Polarity.
2. Plug the welding gun cable into the medium slope terminal located on the welding machine.
3. Plug the ground cable into the negative terminal on the welding machine.
4. Connect the ground cable to the table or metal to be welded.
5. Turn the welding machine power switch to "on."
6. Turn the wire feed control mechanism power switch to "on."
7. Adjust the wire feed speed to zero while setting gas flow, amperage, and voltage.
8. Open the cylinder valve on top of the gas tank.
9. Gas flow should be adjusted to 20 to 25 cubic feet/hour (cfh). Slowly open the flow meter valve located at the top of the cylinder to adjust the amount of shielding gas being delivered to the weld area. The trigger on the welding gun should be depressed while turning the valve on the flow meter to get a reading.
10. Voltage should be adjusted to 19 to 21.
11. Adjust the wire feed control to provide 100 to 120 amps. A trial setting of 5 should be used for wire feed speed and adjusted accordingly in a constant voltage machine.
  - a) In a machine that provides constant current, the amperage is adjusted through the voltage setting. Check the manufacturer's manual to determine if your machine provides constant current or constant voltage.

## Agricultural Construction

---

- b) Run a practice bead to check if the correct amperage is being received.
  - c) To strike an arc, squeeze the trigger on the gun at the same time that the tip of the wire touches the metal to be welded. The assistance of another person will be required to take a reading of the amperage while you are welding.
  - d) You should also check for the correct voltage at this time. Increasing the wire speed will increase the amount of current provided for welding. Decreasing the wire speed will decrease the amount of current.
  - e) When running a test bead, the arc should make a sizzling sound if the proper amount of shielding gas is being used.
12. Adjust the wire stickout to 1/4 to 3/8 inches. The length of stickout is measured from the welding tip to the surface of the metal to be welded.
13. Be sure all equipment is in safe working condition and that proper safety precautions are followed at all times.

### Postwelding Procedure

1. When welding is complete, shut off the valve on the top of the gas cylinder.
2. Bleed the gas from the line by depressing the trigger on the welding gun. If the machine you are using has a button, depressing it will also bleed the gas from the line.
3. Close the flowmeter valve on the top of the gas cylinder to finger tight. This prevents damage to the flow meter the next time the cylinder valve is opened.
4. Turn off the wire feed speed switch.
5. Turn off the power switch on the welding machine.
6. Return cables to the proper storage position.
7. Clean the work area of scrap metal.

## UNIT II - ARC WELDING

### Job Sheet 2.2: Welds in the Flat Position

#### Objective

At the completion of this job sheet, the student will be able to perform butt, lap, and t-fillet welds in the flat position using a GMAW welder.

#### Tools and Equipment Needed

1. GMAW welder
2. Protective clothing
3. Safety goggles\*
4. Pliers
5. Helmet\*

\* **CAUTION:** All students performing and observing this procedure must wear proper eye protection. Safety precautions must be observed while in the shop area.

#### Materials Needed

1. E-70S-3 & E-71S-3 wire - .035 inch diameter
2. Mild steel plates - size to be determined by the instructor

#### Prewelding Procedure

Refer to JS 2.1 for prewelding procedures needed to prepare for welding in a flat position.

#### Welding Procedure

##### BUTT JOINT

1. Lower the helmet. Before striking an arc, tell persons in the area to cover themselves. Tack weld two pieces of mild steel together to form a butt joint. If the metal is thicker than 1/8 inch, the edges of the joint should be beveled to increase penetration. A space of no more than 1/8 inch should be left between the metal plates to increase penetration of the weld.
2. Position the metal so that the joint to be welded is in the flat position. (See Figure 2.1.)
3. The electrode should be positioned at a 90° work angle and a 25° to 30° drag angle to perform the weld. (See Figure 2.2.)
4. Lower the helmet. Strike an arc and adjust the length of wire stickout to provide the desired penetration. Lengthening wire stickout will decrease penetration, whereas decreasing wire stickout will increase the amount of penetration.

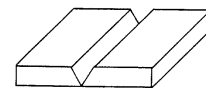

Figure 2.1

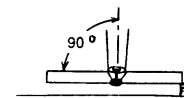

Figure 2.2

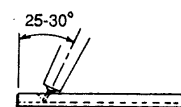

Figure 2.3

# Agricultural Construction

5. Maintain the proper electrode angle while using a slight weaving motion to produce the desired weld.
6. Examine the weld for penetration and bead appearance.
7. Give the weld to the instructor for grading.

## LAP JOINT

1. Lower the helmet. Before striking an arc, tell persons in the area to cover themselves. Tack weld two pieces of mild steel together to form a lap joint. If the metal exceeds 1/8 inch in thickness, the edges of the joint should be beveled to increase penetration.
2. Position the metal so that the joint to be welded is in the flat position. (See Figure 2.4.)
3. The electrode should be positioned at a 90° work angle and a 25° to 30° drag angle to perform the weld. (See Figures 2.5 and 2.6.)
4. Lower the helmet. Strike an arc and adjust the length of wire stickout to provide the desired penetration. Lengthening wire stickout will decrease penetration, whereas decreasing wire stickout will increase the amount of penetration.
5. Maintain the proper electrode angle while using a slight weaving motion to produce the desired weld.
6. Examine the weld for amount of penetration and bead appearance.
7. Give the weld to the instructor for grading.

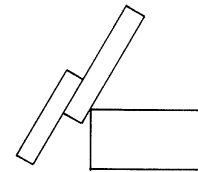

Figure 2.4

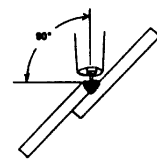

Figure 2.5

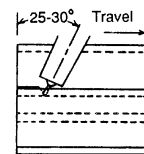

Figure 2.6

## T-FILLET JOINT

1. Lower the helmet. Before striking an arc, tell persons in the area to cover themselves. Tack weld two pieces of mild steel together to form a T-joint. If the metal exceeds 3/8 inch in thickness, the edge of the vertical plate should be beveled to increase penetration.
2. Position the metal so that the joint to be welded is in the flat position. (See Figure 2.7)
3. The electrode should be positioned at a 45° work angle and a 10° drag angle to perform the weld. (See Figures 2.8 and 2.9.)
4. Lower the helmet. Strike the arc and adjust the length of wire stickout to provide the desired penetration. Lengthening wire stickout will increase penetration, whereas decreasing wire stickout will decrease the amount of penetration.
5. Maintain the proper electrode angle while using a slight weaving motion to produce the desired weld.
6. Examine the weld for amount of penetration and bead appearance.
7. Give the weld to the instructor for grading.

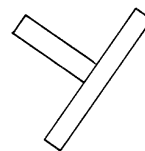

Figure 2.7

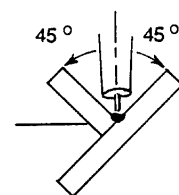

Figure 2.8

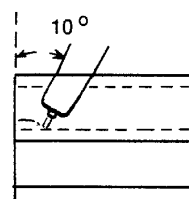

Figure 2.9

## Postwelding Procedure

Refer to JS 2.1 for correct postwelding procedures.

## UNIT II -ARC WELDING

### Job Sheet 2.3: Welds in the Horizontal Position

#### Objective

At the completion of this job sheet, the student will be able to perform a butt and T-fillet weld in the horizontal position using a GMAW welder.

#### Tools and Equipment Needed

1. GMAW welder
2. Protective clothing
3. Safety goggles\*
4. Pliers
5. Helmet\*

\* **CAUTION:** All students performing and observing this procedure must wear proper eye protection. Safety precautions must be observed while in the shop area.

#### Materials Needed

1. E70S-3 & E71S-3 wire - .035 inch diameter
2. Mild steel plates - size to be determined by the instructor

#### Prewelding Procedure

Refer to JS 2.1 for prewelding procedures needed to prepare for welding in the horizontal position.

#### Welding Procedure

##### BUTT JOINT

1. Lower the helmet. Before striking an arc, tell persons in the area to cover themselves. Tack weld two pieces of mild steel together to form a butt joint. If the metal is thicker than 1/8 inch, the edges of the joint should be beveled to increase penetration. A space, no more than 1/8 inch, should be left between the metal plates to increase penetration of the weld.
2. Position the metal so that the joint to be welded will be in the horizontal position. (See Figure 2.1.)
3. The electrode should be positioned at an 85° work angle and a 5° drag angle to perform the weld. (See Figure 2.2.)
4. Lower the helmet. Strike an arc and adjust the length of wire stickout to provide the desired penetration. Lengthening wire stickout will decrease penetration, whereas decreasing wire stickout will increase the amount of

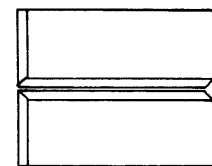

Figure 2.1

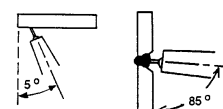

Figure 2.2

# Agricultural Construction

---

penetration.

5. Maintain the proper electrode angle while using a slight weaving motion to produce the desired weld.
6. Examine the weld for penetration and bead appearance.
7. Give the weld to the instructor for grading.

## T-FILLET JOINT

1. Lower the helmet. Before striking an arc, tell persons in the area to cover themselves. Tack weld two pieces of mild steel together to form a T-joint.
2. Position the metal so that the joint to be welded will be in the horizontal position. (See Figure 2.3.)
3. The electrode should be positioned at a  $45^\circ$  work angle and a  $10^\circ$  to  $15^\circ$  drag angle to perform the weld. (See Figures 2.4 and 2.5.)
4. Lower the helmet. Strike an arc and adjust the length of wire stickout to provide the desired penetration. Lengthening wire stickout will decrease penetration, whereas decreasing wire stickout will increase the amount of penetration.
5. Maintain the proper electrode angle while using a slight weaving motion to produce the desired weld.
6. Examine the weld for amount of penetration and bead appearance.
7. Give the weld to the instructor for grading.

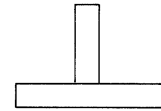

Figure 2.3

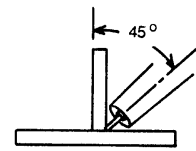

Figure 2.4

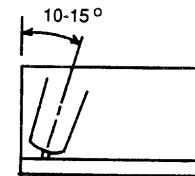

Figure 2.5

## Postwelding Procedure

Refer to JS 2.1 for correct postwelding procedures.

## UNIT II - ARC WELDING

### Job Sheet 2.4: Welds in the Vertical Position

#### Objective

At the completion of this job sheet, the student will be able to perform a butt, lap, and T-fillet weld in the vertical position using a GMAW welder.

#### Tools and Equipment Needed

1. GMAW welder
2. Protective clothing
3. Safety goggles\*
4. Pliers
5. Helmet\*

\* **CAUTION:** All students performing and observing this procedure must wear proper eye protection. Safety precautions must be observed while in the shop area.

#### Materials Needed

1. E-70S-3 & E-71S-3 wire - .035 inch diameter
2. Mild steel plates - size to be determined by the instructor

#### Prewelding Procedure

Refer to JS 2.1 for prewelding procedures needed to prepare for welding in the vertical position.

#### Welding Procedure

##### BUTT JOINT - VERTICAL UP

1. Lower the helmet. Before striking an arc, tell persons in the area to cover themselves. Tack weld two pieces of mild steel together to form a butt joint. If the metal is thicker than 1/8 inch, the edges of the joint should be beveled to increase penetration. A space, no more than 1/8 inch, should be left between the metal plates to increase penetration of the weld.
2. Position the metal so that the joint to be welded is in the vertical position. (See Figure 2.1.)
3. The electrode should be positioned at a 90° work angle and a 10° to 15° push angle to perform the weld. (See Figure 2.2 and 2.3.)
4. Lower the helmet. Strike an arc and adjust the length of wire stickout to provide the desired penetration. Lengthening wire stickout will decrease penetration, while decreasing wire stickout will increase the amount of penetration received.

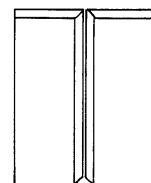

Figure 2.1

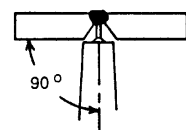

Figure 2.2

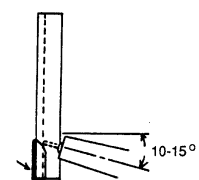

Figure 2.3

## Agricultural Construction

5. Maintain the proper electrode angle while using a slight weaving motion to produce the desired weld.
6. Examine the weld for penetration and bead appearance.
7. Give the weld to the instructor for grading.

### BUTT JOINT - VERTICAL DOWN

1. Lower the helmet. Before striking an arc, tell persons in the area to cover themselves. Tack weld two pieces of mild steel together to form a butt joint. The vertical-down position should only be used when welding thin-gauge metal because the speed of welding required will not allow for adequate penetration of thicker metals.
2. Position the metal so that the joint to be welded is in the vertical position. (See Figure 2.4)
3. The electrode should be positioned at a  $90^\circ$  work angle and a  $10^\circ$  to  $15^\circ$  drag angle to perform the weld. (See Figures 2.5 and 2.6.)
4. Lower the helmet. Strike an arc and adjust the wire stickout to provide the desired penetration. Lengthening wire stickout will decrease penetration, whereas decreasing wire stickout will increase the amount of penetration.
5. Maintain the proper electrode angle while using a slight weaving motion to produce the desired weld. A faster welding speed should be used when making a vertical-up weld. Welding too slowly will result in loss of control of the weld puddle and will increase the chance of burnthrough. Welding too quickly will make it difficult to maintain a stable arc, resulting in poor penetration.
6. Examine the weld for penetration and bead appearance.
7. Give the weld to the instructor for grading.

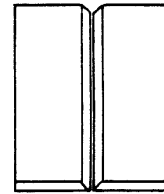

Figure 2.4

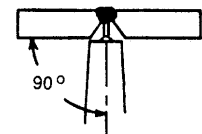

Figure 2.5

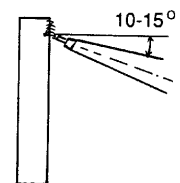

Figure 2.6

### LAP JOINT - VERTICAL UP

1. Lower the helmet. Before striking an arc, tell persons in the area to cover themselves. Tack weld two pieces of mild steel together to form a lap joint.
2. Position the metal so that the joint to be welded is in the vertical position. (See Figure 2.7.)
3. The electrode should be positioned at a  $45^\circ$  work angle and a  $10^\circ$  to  $15^\circ$  push angle to perform the weld. (See Figures 2.8 and 2.9.)
4. Lower the helmet. Strike an arc and adjust the length of wire stickout to provide the desired penetration. Lengthening wire stickout will decrease penetration, whereas decreasing wire stickout will increase the amount of penetration.
5. Maintain the proper electrode angle while using a slight weaving motion to produce the desired weld.
6. Examine the weld for penetration and bead appearance.
7. Give the weld to the instructor for grading.

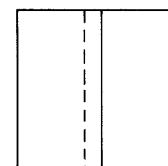

Figure 2.7

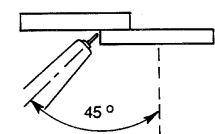

Figure 2.8

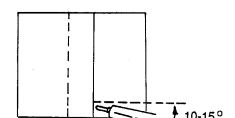

Figure 2.9

### LAP JOINT - VERTICAL DOWN

1. Lower the helmet. Before striking an arc, tell persons in the area to cover



themselves. Tack weld two pieces of mild steel together to form a lap joint. The vertical-down position should only be used when welding thin-gauge metal because the speed of welding required will not allow for adequate penetration of thicker metals.

2. Position the metal so that the joint to be welded is in the vertical position. (See Figure 2.10.)
3. The electrode should be positioned at a 45° work angle and a 10° to 15° drag angle to perform the weld. (See Figures 2.11 and 2.12.)
4. Lower the helmet. Strike an arc and adjust the wire stickout to provide the desired penetration. Lengthening wire stickout will decrease penetration, whereas decreasing wire stickout will increase the amount of penetration.
5. Maintain the proper electrode angle while using a slight weaving motion to produce the desired weld. A faster welding speed should be used than when making a vertical up weld. Welding too slowly will result in loss of control of the weld puddle and will increase the chance of burnthrough. Welding too quickly will make it difficult to maintain a stable arc, resulting in poor penetration.
6. Examine the weld for penetration and bead appearance.
7. Give the weld to the instructor for grading.

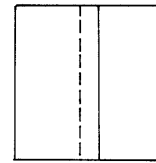

Figure 2.10

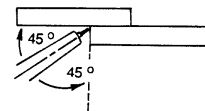

Figure 2.11

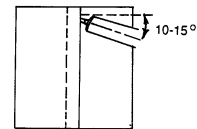

Figure 2.12

### T-FILLET JOINT - VERTICAL UP

1. Lower the helmet. Before striking an arc, tell persons in the area to cover themselves. Tack weld two pieces of mild steel together to form a T-joint.
2. Position the metal so that the joint to be welded will be in the vertical position. (See Figure 2.13.)
3. The electrode should be positioned at a 45° work angle and a 10° to 15° push angle to perform the weld. (See Figures 2.14 and 2.15.)
4. Lower the helmet. Strike an arc and adjust the length of wire to provide the desired penetration. Lengthening wire stickout will decrease penetration, whereas decreasing wire stickout will increase the amount of penetration.
5. Maintain the proper electrode angle while using a slight weaving motion to produce the desired weld.
6. Examine the weld for penetration and bead appearance.
7. Give the weld to the instructor for grading.

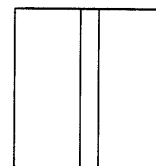

Figure 2.13

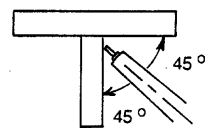

Figure 2.14

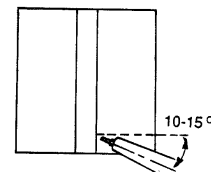

Figure 2.15

### T-FILLET JOINT - VERTICAL DOWN

1. Lower the helmet. Before striking an arc, tell persons in the area to cover themselves. Tack weld two pieces of mild steel together to form a T-joint. The vertical-down position should only be used when welding thin-gauge metal because the speed of welding required will not allow for adequate penetration of thicker metals.
2. Position the metal so that the joint to be welded is in the vertical position. (See Figure 2.16.)
3. The electrode should be positioned at a 45° work angle and a 10° to 15°

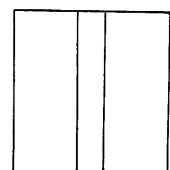

Figure 2.16

# Agricultural Construction

---

drag angle to perform the weld. (See Figures 2.17 and 2.18.)

4. Lower the helmet. Strike an arc and adjust the wire stickout to provide the desired penetration. Lengthening wire stickout will decrease penetration, whereas decreasing wire stickout will increase the amount of penetration.
5. Maintain the proper electrode angle while using a slight weaving motion to produce the desired weld. A faster welding speed should be used than when making a vertical-up weld. Welding too slowly will result in loss of control of the weld puddle and will increase the chance of burnthrough. Welding too quickly will make it difficult to maintain a stable arc, resulting in poor penetration.
6. Examine the weld for penetration and bead appearance.
7. Give the weld to the instructor for grading.

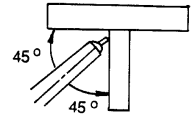

Figure 2.17

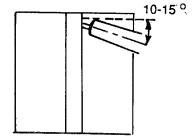

Figure 2.18

## Postwelding Procedure

Refer to JS 2.1 for correct postwelding procedures.

## UNIT II - ARC WELDING

### Job Sheet 2.5: Welds in the Overhead Position

#### Objective

At the completion of this job sheet, the student will be able to perform a butt and T-fillet weld in the overhead position using a GMAW welder.

#### Tools and Equipment Needed

1. GMAW welder
2. Protective clothing
3. Safety goggle\*
4. Pliers
5. Helmet\*
6. Weld positioner

\* **CAUTION:** All students performing and observing this procedure must wear the proper eye protection. Safety precautions must be observed while in the shop area.

#### Materials Needed

1. E-70S-3 & E71S-3 wire - .035 inch diameter
2. Mild steel plates - size to be determined by the instructor

#### Prewelding Procedure

Refer to JS 2.1 for prewelding procedures needed to prepare for welding in the overhead position.

#### Welding Procedure

##### BUTT JOINT

1. Lower the helmet. Before striking an arc, tell persons in the area to cover themselves. Tack weld two pieces of mild steel together to form a butt joint. If the metal is thicker than 1/8 inch, the edges of the joint should be beveled to increase penetration. A space, no more than 1/8 inch, should be left between the metal plates to increase penetration of the weld.
2. Position the metal so that the joint to be welded is in the overhead position. (See Figure 2.1.)
3. The electrode should be positioned at a 90° work angle and a 10° to 15° drag angle to perform the weld. (See Figures 2.2 and 2.3.)
4. Lower the helmet. Strike the arc and adjust the length of wire stickout to provide the desired penetration. Lengthening wire stickout will decrease penetration, whereas decreasing wire stickout will increase the amount of

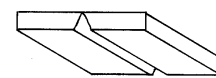

Figure 2.1

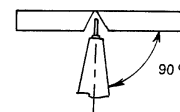

Figure 2.2

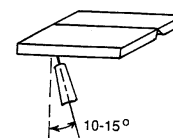

Figure 2.3

# Agricultural Construction

penetration.

5. Maintain the proper electrode angle while using a slight weaving motion to produce the desired weld.
6. Examine the weld for penetration and bead appearance.
7. Give the weld to the instructor for grading.

## LAP JOINT

1. Lower the helmet. Before striking an arc, tell persons in the area to cover themselves. Tack weld two pieces of mild steel together to form a lap joint. If the metal is thicker than 1/8 inch, the edges of the joint should be beveled to increase penetration.
2. Position the metal so that the joint to be welded is in the overhead position. (See Figure 2.4.)
3. The electrode should be positioned at a 45° work angle and a 10° to 15° drag angle to perform the weld. (See Figures 2.5 and 2.6.)
4. Lower the helmet. Strike an arc and adjust the length of wire stickout to provide the desired penetration. Lengthening wire stickout will decrease penetration, whereas decreasing wire stickout will increase the amount of penetration.
5. Maintain the proper electrode angle while using a slight weaving motion to produce the desired weld.
6. Examine the weld for penetration and bead appearance.
7. Give the weld to the instructor for grading.

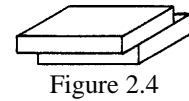

Figure 2.4

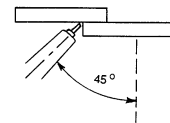

Figure 2.5

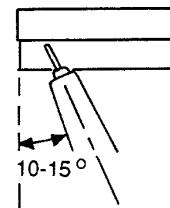

Figure 2.6

## T-FILLET JOINT

1. Lower the helmet. Before striking an arc, tell persons in the area to cover themselves. Tack weld two pieces of mild steel together to form a T-joint.
2. Position the metal so that the joint to be welded is in the overhead position. (See Figure 2.7.)
3. The electrode should be positioned at a 45° work angle and a 10° to 15° drag angle to perform the weld. (See Figures 2.8 and 2.9.)
4. Lower the helmet. Strike an arc and adjust the length of wire stickout to provide the desired penetration. Lengthening wire stickout will decrease penetration, whereas decreasing wire stickout will increase the amount of penetration.
5. Maintain the proper electrode angle while using a slight weaving motion to produce the desired weld.
6. Examine the weld for amount of penetration and bead appearance.
7. Give the weld to the instructor for grading.

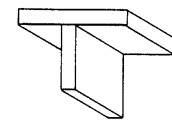

Figure 2.7

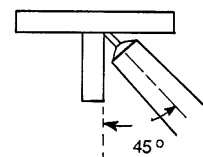

Figure 2.8

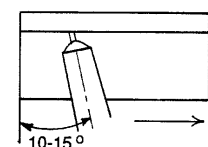

Figure 2.9

## Postwelding Procedure

Refer to JS 2.1 for correct postwelding procedures.

## UNIT III - ARC WELDING

### Gas Tungsten Arc Welding (GTAW) TIG

#### Objective:

The student will be able to make a series of welds in a variety of positions using gas tungsten arc welding.

#### Study Questions

1. What are the principles of GTAW?
2. What are the advantages and limitations of GTAW?
3. What safety and maintenance considerations need to be observed for GTAW?
4. What are the steps for GTAW setup?
5. What are the steps for GTAW shutdown?

#### References

1. Agricultural Engineering Safety Lesson Plan: Arc, TIG, and MIG Welding Safety. Kansas State University Cooperative Extension. Accessed June 17, 2002, from <http://www.cdc.gov/nasd/index.html>.
2. Althouse, A.D., Turnquist, C.H., Bowditch, W.A. Bowditch, K.E. Modern Welding. Tinley Park, IL: The Goodheart-Willcox Company, Inc., 2000.
3. Bowditch, W.A., Bowditch, K.E. Welding Technology Fundamentals. Tinley Park, IL: The Goodheart-Willcox Company, Inc., 1997.
4. Griffin, I.H., Roden, E.M., Jeffus, L., Briggs, C.W. Welding Processes (3rd ed). Albany, NY: Delmar Publishers, Inc., 1984.
5. Jeffus, L. Welding Principles and Applications (4th ed). Albany, NY: Delmar Publishers, 1999.
6. Minnick, W.H. Gas Tungsten Arc Welding Handbook. Tinley Park, IL: The Goodheart-Willcox Company, Inc., 2000.
7. Welding. University of Missouri-Columbia: Instructional Materials Laboratory, July 1988.
8. Demonstration Sheets
  - a) DS 3.1: Prewelding and Postwelding Procedures for GTAW

## Agricultural Construction

---

- b) DS 3.2: Welds in the Flat Position
- c) DS 3.3: Welds in the Horizontal Position
- d) DS 3.4: Welds in the Vertical Position
- e) DS 3.5: Welds in the Overhead Position

### 9. Job Sheets

- a) JS 3.1: Prewelding and Postwelding Procedures for GTAW
- b) JS 3.2: Welds in the Flat Position
- c) JS 3.3: Welds in the Horizontal Position
- d) JS 3.4: Welds in the Vertical Position
- e) JS 3.5: Welds in the Overhead Position

## UNIT III - ARC WELDING

### Gas Tungsten Arc Welding (GTAW) TIG

#### TEACHING PROCEDURES

##### A. Review

Review the lesson on gas metal arc welding. Emphasize its application for agricultural use.

##### B. Motivation

Demonstrate the gas tungsten arc welding process and discuss how it can be applied to agricultural uses. Show students welds that have been made using the GTAW process. Have students compare GTAW joints to those made using other welding methods, such as gas metal arc welding and shielded metal arc welding.

##### C. Assignment

Upon completion of the written evaluation, students should be ready to complete job sheets 3.1 through 3.5.

##### D. Supervised Study

##### E. Discussion

#### 1. What are the principles of GTAW?

**Gas tungsten arc welding (GTAW) differs from gas metal arc welding and shielded metal arc welding. How does GTAW work?**

- a) An electric arc between a nonconsumable tungsten electrode and the base metal produces heat.
- b) “Nonconsumable” means that the electrode does not melt and become part of the weld.
- c) The arc is shielded by an inert gas, such as argon or helium.
- d) Welding can be done with or without filler material. When filler is required, it can be added by dipping a filler rod into the weld pool, by using an automatic feeder, or by placing filler inserts into the weld groove prior to welding.
- e) Shielding gas is stored in a cylinder and delivered to the weld by a regulator, a flowmeter, and a torch.
- f) The regulator reduces the high storage pressure to a lower working pressure and the flowmeter controls the amount of gas going to the torch.
- g) The torch holds the electrode and directs the shielding gas over the weld pool.
- h) Torch nozzles are changed depending on the size of the electrode.
- i) Torches can be air-cooled or water-cooled to remove heat that can build up during welding.

## Agricultural Construction

---

- j) A constant current machine is used for gas tungsten arc welding.
  - 1) Direct current electrode negative (DCEN, previously called direct current straight polarity or DCSP) produces welds with deep penetration.
  - 2) Direct current electrode positive (DCEP, previously called direct current reverse polarity or DCRP) produces wide, shallow beads and also has a cleaning effect on some base metals, such as aluminum.
  - 3) Alternating current (AC) combines the characteristics of DCEN and DCEP and produces welds of medium penetration and has a cleaning effect on some base metals.
  - 4) Direct current may be steady flowing or pulsed. For pulsed arc GTAW, amperage changes between high or peak current and low or background current. Welding is done during peak current periods, and the weld pool cools during background periods. This reduces heat buildup in the base metal and helps control distortion.

### 2. What are the advantages and limitations of GTAW?

Ask students to consider the advantages and limitations of the GTAW process. List them on the board and discuss them.

- a) Advantages
  - 1) The gas tungsten process produces an intense and highly concentrated arc heat with a small heat-affected zone around the weld, which means it is less likely to weaken the base metal.
  - 2) Welds are generally clean. Because GTAW does not use flux, it does not produce slag or residue that can corrode the weld.
  - 3) Metal is not transferred across the arc, as it is in SMAW, which means there is no spatter.
  - 4) It produces welds of high quality. Weld chemistry is easily controlled and welds are usually equal to the base metal and stronger and more ductile than welds made by other processes.
  - 5) The arc and weld pool are clearly visible to the operator because smoke is not produced.
  - 6) Welding is easily done in all positions.
  - 7) The process is adaptable to automatic or semi-automatic operations.
  - 8) It can be used to weld most industrial metals.
- b) Limitations
  - 1) Welding speed is relatively slow.
  - 2) The cost of the equipment and inert gases and the slower speed make GTAW expensive compared to other processes, such as SMAW.
  - 3) The intense heat of the arc can cause some erosion of the electrode to occur. The eroded tungsten can travel across the arc to the weld and make it brittle. With practice and experience, the welder can learn to keep tungsten inclusions to a limited, acceptable level.

### 3. What safety and maintenance considerations need to be observed for GTAW?

**Show students a GTAW machine. How does the GTAW machine compare to other welding equipment they have used? Ask students how safety precautions for GTAW are similar and dissimilar to those for other welding equipment. Discuss any additional safety and maintenance considerations as needed.**



- a) Electrical safety and maintenance
  - 1) Ensure that the welder is properly grounded.
  - 2) Inspect all equipment for damage or defect.
  - 3) Keep all electrical connections tight, clean, and dry.
  - 4) Keep work area, equipment, and clothing dry.
  - 5) Never dip a torch in water to cool it.
  - 6) Disconnect and lock all electrical power sources before performing work on any electrical equipment.
  - 7) Do not use water to extinguish an electrical fire or any fire near the welder.
  - 8) When working in high places, check the area for electrical hazards because a shock could cause a fall.
  - 9) To avoid the risk of shock, do not touch the filler rod to the electrode.
  - 10) Do not use the power supply above the rated load.
  - 11) Do not change the current type or current range switch while welding.
- b) Safety and maintenance of cables, cylinders, and hoses
  - 1) Never drag cables or hoses or pull them to force them over an obstruction.
  - 2) Run hoses and cables so that they will not be damaged or cause a tripping hazard.
  - 3) Use only clean rags to clean cables and hoses. Never use gas or oily rags to clean cables or hoses.
  - 4) Keep cables and hoses free of kinks at all times.
  - 5) Do not drape welding cables or hoses over any type of gas cylinder or over the flowmeter or regulator.
  - 6) Never strike an arc on a gas cylinder.
  - 7) Cylinders must be fastened to a wall, post, or approved cylinder truck so that they stay upright at all times.
  - 8) Valve protection caps should be in place when the cylinder is not in use.
  - 9) Crack (quickly open and close) cylinders before attaching the regulator to clean any debris out of the cylinder valve outlet. Be sure that the valve is not pointed toward anyone.
- c) Personal safety equipment
  - 1) Wear a welding helmet with a filter lens classified as no. 10 or higher, depending on the work being done. Consult the manufacturer's recommendations for the appropriate lens.
    - a. Arc rays can burn both the retina (the back of the eye) and the white of the eye.
    - b. Burns to the whites of the eyes are painful and can easily become infected.
    - c. Burns to the retina, though not painful, can cause loss of sight.
  - 2) Wear safety glasses to protect eyes from flying debris.
  - 3) Wear gloves and high-top leather boots to protect hands and feet. Gloves worn for GTAW are usually thinner than those worn for SMAW or GMAW to give the welder more control over the torch and filler rod.
  - 4) Wear only wool or cotton clothing that is dark and tightly woven to protect the skin from burns and help block arc rays.
  - 5) Wear only long-sleeved shirts that button at the sleeves and collar. Keep the sleeves and shirt buttoned, including the top button at the collar.
  - 6) Wear pants that come down over the top of the boots and do not have cuffs.
  - 7) Wear any additional protective clothing as needed.

## Agricultural Construction

---

- 8) Do not wear clothing with torn or frayed areas that could leave the skin exposed or could easily catch fire from sparks.
  - 9) Workstations and work areas should be shielded to prevent an arc flash injury of nearby workers or visitors.
  - 10) Everyone in the work area should wear appropriate eye protection.
- e) Work area safety
- 1) Keep a fire extinguisher, first-aid kit, and safety equipment within easy reach.
  - 2) Follow all procedures for ensuring adequate ventilation and use forced ventilation or respirators when necessary.
    - a. Gases used in the welding process, such as argon, can displace oxygen and cause dizziness, unconsciousness, or death.
    - b. Respirators should be worn when welding in confined areas. The respirator should be the air-supplied type or a self-contained breathing apparatus.
    - c. Every workstation should be equipped with a ventilation or exhaust system capable of safely removing dangerous fumes and vapors.
  - 5) Appropriate ear protection should be worn in areas subject to high noise levels, especially those levels that are continuous.
  - 6) Follow all manufacturer recommendations for solvents and cleaning agents used to clean metal. Failure to do so can result in chemical burns, toxic fumes, or fire hazards.
  - 7) When grinding a tungsten, be sure to keep the palms of the hands clear of the back end of the tungsten in case the grinding wheel suddenly pushes it back or downward.
  - 8) Lighting should be bright enough to provide good visibility free of glare. Poorly lit areas contribute to eye fatigue, irritation, and poor work.

#### 4. What are the steps for GTAW setup?

**It is necessary to know how to start and shut down GTAW equipment. Ask students why proper setup is necessary. What problems may result with missed steps?**

- a) With the power off, attach the torch hoses to the machine.
- b) Crack the cylinder valve and attach the flowmeter and regulator to the shielding gas cylinder.
- c) Attach the gas hose from the flowmeter to the machine.
- d) With the power still off, switch the machine to GTAW, select the type of current, and set the current range.
- e) Set the high frequency switch.
- f) Set up the remote control.
- g) Set the shielding gas postflow timer and adjust the gas flow according to the size of the electrode.
- h) Check for proper and complete circulation in the cooling system and verify that there are no leaks.
- i) Select the correct size collet body, collet, and nozzle.
- j) Select and prepare the tungsten.
- k) Adjust electrode extension (the length the electrode extends beyond the nozzle opening).
- l) Attach the ground clamp to the base metal.
- m) Switch on the machine.

## 5. What are the steps for GTAW shutdown?

**Following the proper shutdown procedure is important for the user's safety and for the life of the equipment. Once students have been introduced to the setup procedure for GTAW, ask them what steps should be followed for shutdown. Use DS 3.1 and JS 3.1.**

- a) Close the gas cylinder valve. Depress the foot control to bleed the gas line.
- b) Shut off the flowmeter, cooling system, and power switch.
- c) Remove the electrode from the torch and return it to its proper storage.
- d) Remove the collet, collet body, and nozzle and return them to their proper storage.
- e) Disconnect the ground clamp.
- f) Roll cables neatly. Return any remaining materials and equipment to their proper places.
- g) Clean the work area.

## F. Other Activities

1. Put together a safety checklist card for GTAW equipment. Distribute copies to students and post a large, easily visible version in the work area.

## G. Conclusion

Gas tungsten arc welding uses a nonconsumable tungsten electrode, a shielding gas, and heat from an electric arc to weld. Filler may or may not be used. Gas tungsten arc welding is slower and more expensive than some procedures, but it can produce excellent, slag-free welds on most industrial metals.

## H. Competency

Weld in all positions with the gas tungsten arc welder.

- a. Weld in flat position
- b. Weld in vertical position
- c. Weld in horizontal position
- d. Weld in overhead position

## I. Answers to Evaluation

1. Students should provide four of the following:
  - a. The GTAW process produces an intense heat with a small heat-affected zone around the weld, which means it is less likely to weaken the base metal.
  - b. Welds are generally clean because GTAW doesn't use flux.
  - c. Metal is not transferred across the arc, so no spatter is produced.
  - d. It produces a high quality weld. Welds are usually equal to the base metal and stronger and more ductile than welds made by other processes.
  - e. The arc and weld pool are clearly visible because smoke is not produced.
  - f. Welding is easily done in all positions.
  - g. It is adaptable to automatic and semi-automatic operations.

## Agricultural Construction

---

- h. It can be used to weld most industrial metals.
2. Students should provide two of the following:
    - a. Weld speed is relatively slow.
    - b. It is expensive because of the equipment and gas.
    - c. The intense heat of the arc can cause some erosion of the electrode. This eroded tungsten can travel across the arc and make welds brittle.
  3. An electric arc between a nonconsumable tungsten electrode and the base metal produces heat. The arc is shielded by an inert gas, such as argon or helium, and welding can be done with or without filler.
  4. Cracking the cylinder cleans any debris out of the cylinder valve outlet.
  5. Good ventilation is necessary to prevent the accumulation of dangerous fumes and vapors. Gases used in the welding process, such as argon, can displace oxygen and cause dizziness, unconsciousness, or death.
  6. Arc rays can burn the retina and the white of the eye. Burns to the whites of the eyes are painful and can easily become infected. Burns to the retina can cause loss of sight.
  7. d
  8. c

## UNIT III - ARC WELDING

Gas Tungsten Arc Welding

Name \_\_\_\_\_

(GTAW) / TIG

Date \_\_\_\_\_

### EVALUATION

**Complete the following short answer questions.**

1. Name four advantages of GTAW.
  - a.
  - b.
  - c.
  - d.
2. Name two limitations of GTAW.
  - a.
  - b.
3. How is a GTAW weld made?
4. What is the purpose of cracking a gas cylinder?
5. Why should a welding area be well ventilated?

## Agricultural Construction

---

6. Why is a helmet with a filter lens needed for welding?

**Circle the letter that corresponds to the best answer.**

7. Which of the following is a step in setting up a gas tungsten arc welder?

- a. Disconnect the ground clamp.
- b. Drape the hoses over the gas cylinder.
- c. Dip the torch in water.
- d. Attach the flowmeter and regulator.

8. Which of the following is a step in shutting down a gas tungsten arc welder?

- a. Set shielding gas postflow.
- b. Attach hoses with the power off.
- c. Clean the work area.
- d. Prepare the tungsten.

## UNIT III - ARC WELDING

### Demonstration Sheet 3.1: Prewelding and Postwelding Procedures for GTAW

#### Objective

At the completion of this demonstration, the student will be prepared to begin the job sheet in setting up, adjusting, and shutting down the gas tungsten arc welding machine.

#### Tools and Equipment Needed

1. GTAW machine and accessories
2. Protective clothing
3. Safety goggles\*
4. Helmet
5. Adjustable wrench or appropriate open-end wrench
6. Shielding gas cylinder
7. Tungsten
8. Pliers

\* CAUTION: Everyone participating in or observing the demonstration should wear appropriate protective eyewear. Safety precautions should be observed while in the shop area.

#### Materials Needed

1. Metal plates - type and size to be determined by the instructor
2. Filler metal - per instructor

#### Prewelding Procedures

1. With the power off, attach the torch hoses to the machine.
2. Check that the gas cylinder is safely secured in an upright position. Remove the cylinder cap. Crack the cylinder to clear the cylinder valve fitting.
3. Attach the flowmeter and regulator to the cylinder valve. Tighten the regulator fitting nut with the wrench, but do not overtighten.
4. Attach the gas hose from the flowmeter to the machine.
5. With the power still off, switch the machine to GTAW, select the type of current, and set the current range according to metal thickness.
6. Set the high frequency switch.
7. Set the spark control for soft start. Set up the remote control, depending on the machine's accessories.
8. Set the shielding gas postflow timer according to electrode size.
9. Check to be sure that the flowmeter adjusting valve is shut off. If it isn't, turn it clockwise until it is tight.

## Agricultural Construction

---

10. Stand to one side and turn on the cylinder valve.
11. Adjust gas flow according to the size of the electrode.
12. Check for proper and complete circulation in the cooling system and verify that there are no leaks.
13. Select the correct size collet body, collet, and nozzle according to the electrode size.
14. Select and prepare the tungsten.
15. Adjust electrode extension (the length the electrode extends beyond the nozzle opening).
16. Attach the ground clamp to the base metal.
17. Switch on the machine.
18. Position the base metal and hold the torch with the dominant hand. Move the torch so that the nozzle rests on the metal with the electrode about 3/16 in. off the surface.
19. Cover up and remind others in the area to do so as well. Depress the foot control until an arc jumps the gap. Correct the electrode angle as soon as the arc is established.
20. Preheat the starting point until a small molten puddle is formed.  
Move the filler rod into the leading edge of the molten puddle and let a drop or two of molten filler metal fill the puddle.
21. Withdraw the filler rod about 1/2 in. from the arc so the torch and puddle can be moved in the direction of travel; be sure to keep the end of the rod in the shielded area.
22. Move the puddle forward while using the torch to maintain a uniform bead width, then reinsert the filler rod into the center of the molten puddle at the point of the arc, letting a drop or two of filler metal fill the puddle.
23. Repeat the procedure until the stringer bead is completed.
24. Stop at the edge of the plate and release the foot control. Keep the torch in place for a few seconds after the weld is completed.
25. Shut down the welding machine.
26. Explain any additional features of your gas tungsten arc welding machine.

### Postwelding Procedure

1. When welding is complete, close the gas cylinder valve. Depress the foot control to bleed the gas line.
2. Shut off the flowmeter, cooling system, and power switch.
3. Remove the electrode from the torch and return it to its proper storage.
4. Remove the collet, collet body, and nozzle and return them to their proper storage.
5. Disconnect the ground clamp.
6. Roll cables neatly. Return any remaining materials and equipment to their proper places.
7. Clean the work area.



## UNIT III - ARC WELDING

### Demonstration Sheet 3.2: Welds in the Flat Position

#### Objective

At the completion of the demonstration, the student will be prepared to begin the job sheet in performing butt, lap, and T-fillet welds in the flat position using a GTAW welder.

#### Tools and Equipment Needed

1. GTAW machine and accessories
2. Protective clothing
3. Safety goggles\*
4. Helmet
5. Adjustable wrench or appropriate open-end wrench
6. Shielding gas cylinder
7. Tungsten
8. Pliers

\* CAUTION: Everyone participating in or observing the demonstration should wear appropriate protective eyewear. Safety precautions must be observed while in the shop area.

#### Materials Needed

1. Filler metal - per instructor
2. Mild steel plates - size to be determined by the instructor

#### Prewelding Procedure

Refer to DS 3.1 for prewelding procedures.

#### Welding Procedure

##### BUTT JOINT

1. Lower the helmet. Tack weld two pieces of mild steel together to form a butt joint. "Cover" should be said before striking an arc. If the metal is thicker than 1/8 inch, the edges of the joint should be beveled to increase penetration. A space, approximately 1/16 inch, should be left between the metal plates to increase penetration of the weld.
2. Position the metal so that the joint to be welded will be in flat position.
3. The electrode should be perpendicular to the surface of the weld and pointed forward with the torch approximately 70 to 80 degrees from the weld axis. The filler rod is held at a 15 to 20 degree angle to the plate.
4. Lower the helmet and strike the arc.

## Agricultural Construction

---

5. Move the filler rod into the leading edge of the molten puddle and let a drop or two of molten filler metal fill the puddle.
6. Withdraw the filler rod about 1/2 inch from the arc so the torch and puddle can be moved in the direction of travel; be sure to keep the end of the rod in the shielded area.
7. Advance the puddle while using the torch to maintain a uniform bead width. Then reinsert the filler rod into the center of the molten puddle at the point of the arc; let a drop or two of molten filler metal fill the puddle.
8. Repeat the procedure until the weld is complete.
9. Stop just as you reach the end of the plate and let off the foot control. Keep the torch in place for a few seconds after the end of the weld.
10. Examine the weld for penetration and bead appearance.
11. Discuss possible improvements with students and how these improvements might be accomplished.

### LAP JOINT

1. Lower the helmet. Tack weld two pieces of mild steel together to form a lap joint. “Cover” should be said before striking an arc.
2. Position the metal so that the joint to be welded will be in flat position.
3. The electrode should be held at a 45 degree angle to the surface of the weld and pointed forward at approximately 70 to 80 degrees from the weld axis. The filler rod is held at a 15 to 20 degree angle to the plate.
4. Lower the helmet and strike the arc.
5. Move the filler rod into the leading edge of the molten puddle and let a drop or two of molten filler metal fill the puddle.
6. Withdraw the filler rod about 1/2 inch from the arc so the torch and puddle can be moved in the direction of travel; be sure to keep the end of the rod in the shielded area.
7. Advance the puddle while using the torch to maintain a uniform bead width. Then reinsert the filler rod into the center of the molten puddle at the point of the arc; let a drop or two of molten filler metal fill the puddle.
8. Repeat the procedure until the weld is complete.
9. Stop just as you reach the end of the plate and let off the foot control. Keep the torch in place for a few seconds after the end of the weld.
10. Examine the weld for penetration and bead appearance.
11. Discuss possible improvements with students and how these improvements might be accomplished.

### T-FILLET JOINT

1. Lower the helmet. Tack weld two pieces of mild steel together to form a T joint. “Cover” should be said before striking an arc.
2. Position the metal so that the joint to be welded will be in flat position.
3. The electrode should be held at a 45 degree angle to the surface of the weld and pointed forward at approximately 70 to 80 degrees from the weld axis. The filler rod is held at a 15 to 20 degree angle to the plate.
4. Lower the helmet and strike the arc.
5. Move the filler rod into the leading edge of the molten puddle and let a drop or two of molten filler metal fill the puddle.
6. Withdraw the filler rod about 1/2 inch from the arc so the torch and puddle can be moved in the direction of travel; be sure to keep the end of the rod in the shielded area.

7. Advance the puddle while using the torch to maintain a uniform bead width. Then reinsert the filler rod into the center of the molten puddle at the point of the arc; let a drop or two of molten filler metal fill the puddle.
8. Repeat the procedure until the weld is complete.
9. Stop just as you reach the end of the plate and let off the foot control. Keep the torch in place for a few seconds after the end of the weld.
10. Examine the weld for penetration and bead appearance.
11. Discuss possible improvements with students and how these improvements might be accomplished.

### **Postwelding Procedure**

Refer to DS 3.1 for postwelding procedures.



## UNIT III -ARC WELDING

### Demonstration Sheet 3.3: Welds in the Horizontal Position

#### Objective

At the completion of this demonstration, the student will be ready to begin the job sheet in performing butt, lap, and T-fillet welds in the horizontal position using a GTAW welder.

#### Tools and Equipment Needed

1. GTAW machine and accessories
2. Protective clothing
3. Safety goggles\*
4. Helmet
5. Adjustable wrench or appropriate open-end wrench
6. Shielding gas cylinder
7. Tungsten
8. Pliers

\* CAUTION: Everyone participating in or observing the demonstration should wear appropriate protective eyewear. Safety precautions must be observed while in the shop area.

#### Materials Needed

1. Filler metal - per instructor
2. Mild steel plates - size to be determined by the instructor

#### Prewelding Procedure

Refer to DS 3.1 for prewelding procedures needed to prepare for horizontal position welding.

#### Welding Procedure

##### BUTT JOINT

1. Lower the helmet. Tack weld two pieces of mild steel together to form a butt joint. "Cover" should be said before striking an arc. If the metal is thicker than 1/8 inch, the edges of the joint should be beveled to increase penetration. A space, approximately 1/16 inch, should be left between the metal plates to increase penetration of the weld.
2. Position the metal so that the joint to be welded will be in the horizontal position.
3. The torch should be held 75 to 80 degrees to the surface of the weld and the back of the torch should be tipped downward so that the electrode is pointing up toward the weld at a 15 degree angle. The filler rod is held at a 20 degree angle to the plate.
4. Lower the helmet and strike the arc.

## Agricultural Construction

---

5. Move the filler rod into the leading edge of the molten puddle and let a drop or two of molten filler metal fill the puddle.
6. Withdraw the filler rod about 1/2 inch from the arc so the torch and puddle can be moved in the direction of travel; be sure to keep the end of the rod in the shielded area.
7. Advance the puddle while using the torch to maintain a uniform bead width. Then reinsert the filler rod into the center of the molten puddle at the point of the arc; let a drop or two of molten filler metal fill the puddle.
8. Repeat the procedure until the weld is complete.
9. Stop just as you reach the end of the plate and let off the foot control. Keep the torch in place for a few seconds after the end of the weld.
10. Examine the weld for penetration and bead appearance.
11. Discuss possible improvements with students and how these improvements might be accomplished.

### LAP JOINT

1. Lower the helmet. Tack weld two pieces of mild steel together to form a lap joint. "Cover" should be said before striking an arc.
2. Position the metal so that the joint to be welded will be in the horizontal position.
3. The electrode should be held 45 degrees to the surface of the weld and pointed forward at 70 to 80 degrees from the weld axis. The filler rod is held at a 20 degree angle to the plate.
4. Lower the helmet and strike the arc.
5. Move the filler rod into the leading edge of the molten puddle and let a drop or two of molten filler metal fill the puddle.
6. Withdraw the filler rod about 1/2 inch from the arc so the torch and puddle can be moved in the direction of travel; be sure to keep the end of the rod in the shielded area.
7. Advance the puddle while using the torch to maintain a uniform bead width. Then reinsert the filler rod into the center of the molten puddle at the point of the arc; let a drop or two of molten filler metal fill the puddle.
8. Repeat the procedure until the weld is complete.
9. Stop just as you reach the end of the plate and let off the foot control. Keep the torch in place for a few seconds after the end of the weld.
10. Examine the weld for penetration and bead appearance.
11. Discuss possible improvements with students and how these improvements might be accomplished.

### T-FILLET JOINT

1. Lower the helmet. Tack weld two pieces of mild steel together to form a T joint. "Cover" should be said before striking an arc.
2. Position the metal so that the joint to be welded will be in the horizontal position.
3. The electrode should be held 45 degrees to the surface of the weld and pointed forward at 70 to 80 degrees from the weld axis. The filler rod is held at a 15 to 20 degree angle to the plate.
4. Lower the helmet and strike the arc.
5. Move the filler rod into the leading edge of the molten puddle and let a drop or two of molten filler metal fill the puddle.
6. Withdraw the filler rod about 1/2 inch from the arc so the torch and puddle can be moved in the direction of travel; be sure to keep the end of the rod in the shielded area.

7. Advance the puddle while using the torch to maintain a uniform bead width. Then reinsert the filler rod into the center of the molten puddle at the point of the arc; let a drop or two of molten filler metal fill the puddle.
8. Repeat the procedure until the weld is complete.
9. Stop just as you reach the end of the plate and let off the foot control. Keep the torch in place for a few seconds after the end of the weld.
10. Examine the weld for penetration and bead appearance.
11. Discuss possible improvements with students and how these improvements might be accomplished.

### **Postwelding Procedure**

Refer to DS 3.1 for postwelding procedures.





## UNIT III - ARC WELDING

### Demonstration Sheet 3.4: Welds in the Vertical Position

#### Objective

At the completion of this demonstration, the student will be ready to begin the job sheet in performing butt, lap, and T-fillet welds in the vertical position using a GTAW welder.

#### Tools and Equipment Needed

1. GTAW machine and accessories
2. Protective clothing
3. Safety goggles\*
4. Helmet
5. Adjustable wrench or appropriate open-end wrench
6. Shielding gas cylinder
7. Tungsten
8. Pliers

\* CAUTION: Everyone participating in or observing the demonstration should wear appropriate protective eyewear. Safety precautions must be observed while in the shop area.

#### Materials Needed

1. Filler metal - per instructor
2. Mild steel plates - size to be determined by the instructor

#### Prewelding Procedure

Refer to DS 3.1 for prewelding procedures.

#### Welding Procedure

##### BUTT JOINT

1. Lower the helmet. Tack weld two pieces of mild steel together to form a butt joint. "Cover" should be said before striking an arc. If the metal is thicker than 1/8 inch, the edges of the joint should be beveled to increase penetration. A space, approximately 1/16 inch, should be left between the metal plates to increase penetration of the weld.
2. Position the metal so that the joint to be welded will be in the vertical position. For thicker metal, it is best to weld with the weld pool moving from the bottom to the top, or vertically up. For thinner metal, it is best to weld with the pool moving from the top to the bottom, or vertically down.
3. The torch should be held perpendicular to the surface of the weld and tipped down so that the torch is 75 to 80 degrees from the base metal. The filler rod is held at an angle of approximately 35 to 45 degrees to the plate.

## Agricultural Construction

---

4. Lower the helmet and strike the arc.
5. Move the filler rod into the leading edge of the molten puddle and let a drop or two of molten filler metal fill the puddle.
6. Withdraw the filler rod about 1/2 inch from the arc so the torch and puddle can be moved in the direction of travel; be sure to keep the end of the rod in the shielded area.
7. Advance the puddle while using the torch to maintain a uniform bead width. Then reinsert the filler rod into the center of the molten puddle at the point of the arc; let a drop or two of molten filler metal fill the puddle.
8. Repeat the procedure until the weld is complete.
9. Stop just as you reach the end of the plate and let off the foot control. Keep the torch in place for a few seconds after the end of the weld.
10. Examine the weld for penetration and bead appearance.
11. Discuss possible improvements with students and how these improvements might be accomplished.

### LAP JOINT

1. Lower the helmet. Tack weld two pieces of mild steel together to form a lap joint. "Cover" should be said before striking an arc.
2. Position the metal so that the joint to be welded will be in the vertical position. For thicker metal, it is best to weld with the weld pool moving from the bottom to the top, or vertically up. For thinner metal, it is best to weld with the pool moving from the top to the bottom, or vertically down.
3. The torch should be centered over the root of the weld and tipped down so that the torch is 75 to 80 degrees from the base metal. The filler rod is held at an angle of approximately 35 to 45 degrees to the plate.
4. Lower the helmet and strike the arc.
5. Move the filler rod into the leading edge of the molten puddle and let a drop or two of molten filler metal fill the puddle.
6. Withdraw the filler rod about 1/2 inch from the arc so the torch and puddle can be moved in the direction of travel; be sure to keep the end of the rod in the shielded area.
7. Advance the puddle while using the torch to maintain a uniform bead width. Then reinsert the filler rod into the center of the molten puddle at the point of the arc; let a drop or two of molten filler metal fill the puddle.
8. Repeat the procedure until the weld is complete.
9. Stop just as you reach the end of the plate and let off the foot control. Keep the torch in place for a few seconds after the end of the weld.
10. Examine the weld for penetration and bead appearance.
11. Discuss possible improvements with students and how these improvements might be accomplished.

### T-FILLET JOINT

1. Lower the helmet. Tack weld two pieces of mild steel together to form a T joint. "Cover" should be said before striking an arc.
2. Position the metal so that the joint to be welded will be in the vertical position. For thicker metal, it is best to weld with the weld pool moving from the bottom to the top, or vertically up. For thinner metal, it is best to weld with the pool moving from the top to the bottom, or vertically down.
3. The torch should be centered over the root of the weld and tipped down so that the torch is 75 to 80 degrees from the base metal. The filler rod is held at an angle of approximately 35 to 45 degrees to the plate.

4. Lower the helmet and strike the arc.
5. Move the filler rod into the leading edge of the molten puddle and let a drop or two of molten filler metal fill the puddle.
6. Withdraw the filler rod about 1/2 inch from the arc so the torch and puddle can be moved in the direction of travel; be sure to keep the end of the rod in the shielded area.
7. Advance the puddle while using the torch to maintain a uniform bead width. Then reinsert the filler rod into the center of the molten puddle at the point of the arc; let a drop or two of molten filler metal fill the puddle.
8. Repeat the procedure until the weld is complete.
9. Stop just as you reach the end of the plate and let off the foot control. Keep the torch in place for a few seconds after the end of the weld.
10. Examine the weld for penetration and bead appearance.
11. Discuss possible improvements with students and how these improvements might be accomplished.

### **Postwelding Procedure**

Refer to DS 3.1 for postwelding procedures.



## UNIT III -ARC WELDING

### Demonstration Sheet 3.5: Welds in the Overhead Position

#### Objective

At the completion of this demonstration, the student will be ready to begin the shop exercise in performing butt, lap, and T-fillet weld in the overhead position using a GTAW welder.

#### Tools and Equipment Needed

1. GTAW machine and accessories
2. Protective clothing
3. Safety goggles\*
4. Helmet
5. Adjustable wrench or appropriate open-end wrench
6. Shielding gas cylinder
7. Tungsten
8. Pliers

\* CAUTION: Everyone participating in or observing the demonstration should wear appropriate protective eyewear. Safety precautions must be observed while in the shop area.

#### Materials Needed

1. Filler metal - per instructor
2. Mild steel plates - size to be determined by the instructor

#### Prewelding Procedure

Refer to DS 3.1 for prewelding procedures.

#### Welding Procedure

##### BUTT JOINT

1. Lower the helmet. Tack weld two pieces of mild steel together to form a butt joint. "Cover" should be said before striking an arc. If the metal is thicker than 1/8 inch, the edges of the joint should be beveled to increase penetration. A space, approximately 1/16 inch, should be left between the metal plates to increase penetration of the weld.
2. Position the metal so that the joint to be welded will be in the overhead position.
3. The electrode should be perpendicular to the surface of the weld and pointed forward with the torch approximately 70 to 80 degrees from the weld axis. The filler rod is held at a 15 to 20 degree angle to the plate.
4. Lower the helmet and strike the arc.

## Agricultural Construction

---

5. Move the filler rod into the leading edge of the molten puddle and let a drop or two of molten filler metal fill the puddle.
6. Withdraw the filler rod about 1/2 inch from the arc so the torch and puddle can be moved in the direction of travel; be sure to keep the end of the rod in the shielded area.
7. Advance the puddle while using the torch to maintain a uniform bead width. Then reinsert the filler rod into the center of the molten puddle at the point of the arc; let a drop or two of molten filler metal fill the puddle.
8. Repeat the procedure until the weld is complete.
9. Stop just as you reach the end of the plate and let off the foot control. Keep the torch in place for a few seconds after the end of the weld.
10. Examine the weld for penetration and bead appearance.
11. Discuss possible improvements with students and how these improvements might be accomplished.

### LAP JOINT

1. Lower the helmet. Tack weld two pieces of mild steel together to form a lap joint. "Cover" should be said before striking an arc.
2. Position the metal so that the joint to be welded will be in the overhead position.
3. The electrode should be held at a 45 degree angle to the surface of the weld and pointed forward at approximately 70 to 80 degrees from the weld axis. The filler rod is held at a 15 to 20 degree angle to the plate.
4. Lower the helmet and strike the arc.
5. Move the filler rod into the leading edge of the molten puddle and let a drop or two of molten filler metal fill the puddle.
6. Withdraw the filler rod about 1/2 inch from the arc so the torch and puddle can be moved in the direction of travel; be sure to keep the end of the rod in the shielded area.
7. Advance the puddle while using the torch to maintain a uniform bead width. Then reinsert the filler rod into the center of the molten puddle at the point of the arc; let a drop or two of molten filler metal fill the puddle.
8. Repeat the procedure until the weld is complete.
9. Stop just as you reach the end of the plate and let off the foot control. Keep the torch in place for a few seconds after the end of the weld.
10. Examine the weld for penetration and bead appearance.
11. Discuss possible improvements with students and how these improvements might be accomplished.

### T-FILLET JOINT

1. Lower the helmet. Tack weld two pieces of mild steel together to form a T joint. "Cover" should be said before striking an arc.
2. Position the metal so that the joint to be welded will be in the overhead position.
3. The electrode should be held at a 45 degree angle to the surface of the weld and pointed forward at approximately 70 to 80 degrees from the weld axis. The filler rod is held at a 15 to 20 degree angle to the plate.
4. Lower the helmet and strike the arc.
5. Move the filler rod into the leading edge of the molten puddle and let a drop or two of molten filler metal fill the puddle.
6. Withdraw the filler rod about 1/2 inch from the arc so the torch and puddle can be moved in the direction of travel; be sure to keep the end of the rod in the shielded area.

7. Advance the puddle while using the torch to maintain a uniform bead width. Then reinsert the filler rod into the center of the molten puddle at the point of the arc; let a drop or two of molten filler metal fill the puddle.
8. Repeat the procedure until the weld is complete.
9. Stop just as you reach the end of the plate and let off the foot control. Keep the torch in place for a few seconds after the end of the weld.
10. Examine the weld for penetration and bead appearance.
11. Discuss possible improvements with students and how these improvements might be accomplished.

### **Postwelding Procedure**

Refer to DS 3.1 for postwelding procedures.





## UNIT III - ARC WELDING

### Job Sheet 3.1: Prewelding and Postwelding Procedures for GTAW

#### Objective

At the completion of this job sheet, the student will be able to set up, adjust, and shut down the machine used for gas tungsten arc welding.

#### Tools and Equipment Needed

1. GTAW machine and accessories
2. Protective clothing
3. Safety goggles\*
4. Helmet
5. Adjustable wrench or appropriate open-end wrench
6. Shielding gas cylinder
7. Tungsten
8. Pliers

\* CAUTION: Everyone participating in or observing this procedure should wear appropriate protective eyewear. Safety precautions should be observed while in the shop area.

#### Materials Needed

1. Metal plates - type and size to be determined by the instructor
2. Filler metal - per instructor

#### Prewelding Procedures

1. Be sure all equipment is in safe working condition and that proper safety precautions are followed at all times.
2. With the power off, attach the torch hoses to the machine.
3. Check that the gas cylinder is safely secured in an upright position. Remove the cylinder cap. Crack the cylinder to clear the cylinder valve fitting.
4. Attach the flowmeter and regulator to the cylinder valve. Tighten the regulator fitting nut with the wrench, but do not overtighten.
5. Attach the gas hose from the flowmeter to the machine.
6. With the power still off, switch the machine to GTAW, select the type of current, and set the current range according to metal thickness.
7. Set the high frequency switch.
8. Set the spark control for soft start. Set up the remote control, depending on the machine's accessories.
9. Set the shielding gas postflow timer according to electrode size.

## Agricultural Construction

---

10. Check to be sure that the flowmeter adjusting valve is shut off. If it isn't, turn it clockwise until it is tight.
11. Stand to one side and turn on the cylinder valve.
12. Adjust gas flow according to the size of the electrode.
13. Check for proper and complete circulation in the cooling system and verify that there are no leaks.
14. Select the correct size collet body, collet, and nozzle according to the electrode size.
15. Select and prepare the tungsten.
16. Adjust electrode extension (the length the electrode extends beyond the nozzle opening).
17. Attach the ground clamp to the base metal.
18. Switch on the machine.
19. Position the base metal and hold the torch with the dominant hand. Move the torch so that the nozzle rests on the metal with the electrode about 3/16 in. off the surface.
20. Cover up and remind others in the area to do so as well. Depress the foot control until an arc jumps the gap. Correct the electrode angle as soon as the arc is established.
21. Preheat the starting point until a small molten puddle is formed.  
Move the filler rod into the leading edge of the molten puddle and let a drop or two of molten filler metal fill the puddle.
22. Withdraw the filler rod about 1/2 in. from the arc so the torch and puddle can be moved in the direction of travel; be sure to keep the end of the rod in the shielded area.
23. Move the puddle forward while using the torch to maintain a uniform bead width, then reinsert the filler rod into the center of the molten puddle at the point of the arc, letting a drop or two of filler metal fill the puddle.
24. Repeat the procedure until the stringer bead is completed.
25. Stop at the edge of the plate and release the foot control. Keep the torch in place for a few seconds after the weld is completed.
26. Ask the instructor to check the results of the procedure.

### Postwelding Procedure

1. When welding is complete, close the gas cylinder valve. Depress the foot control to bleed the gas line.
2. Shut off the flowmeter, cooling system, and power switch.
3. Remove the electrode from the torch and return it to its proper storage.
4. Remove the collet, collet body, and nozzle and return them to their proper storage.
5. Disconnect the ground clamp.
6. Roll cables neatly. Return any remaining materials and equipment to their proper places.
7. Clean the work area.
8. Ask the instructor to check the results of the procedure.

## UNIT III - ARC WELDING

### Job Sheet 3.2: Welds in the Flat Position

#### Objective

At the completion of this job sheet, the student will be able to perform butt, lap, and T-fillet welds in the flat position using a GTAW welder.

#### Tools and Equipment Needed

1. GTAW machine and accessories
2. Protective clothing
3. Safety goggles\*
4. Helmet
5. Adjustable wrench or appropriate open-end wrench
6. Shielding gas cylinder
7. Tungsten
8. Pliers

\* CAUTION: Everyone participating in or observing the procedure should wear appropriate protective eyewear. Safety precautions must be observed while in the shop area.

#### Materials Needed

1. Filler metal - per instructor
2. Mild steel plates - size to be determined by the instructor

#### Prewelding Procedure

Refer to JS 3.1 for prewelding procedures.

#### Welding Procedure

##### BUTT JOINT

1. Lower the helmet. Tack weld two pieces of mild steel together to form a butt joint. "Cover" should be said before striking an arc. If the metal is thicker than 1/8 inch, the edges of the joint should be beveled to increase penetration. A space, approximately 1/16 inch, should be left between the metal plates to increase penetration of the weld.
2. Position the metal so that the joint to be welded will be in flat position.
3. The electrode should be perpendicular to the surface of the weld and pointed forward with the torch approximately 70 to 80 degrees from the weld axis. The filler rod is held at a 15 to 20 degree angle to the plate.
4. Lower the helmet and strike the arc.

## Agricultural Construction

---

5. Move the filler rod into the leading edge of the molten puddle and let a drop or two of molten filler metal fill the puddle.
6. Withdraw the filler rod about 1/2 inch from the arc so the torch and puddle can be moved in the direction of travel; be sure to keep the end of the rod in the shielded area.
7. Advance the puddle while using the torch to maintain a uniform bead width. Then reinsert the filler rod into the center of the molten puddle at the point of the arc; let a drop or two of molten filler metal fill the puddle.
8. Repeat the procedure until the weld is complete.
9. Stop just as you reach the end of the plate and let off the foot control. Keep the torch in place for a few seconds after the end of the weld.
10. Examine the weld for penetration and bead appearance.
11. Turn in the weld to the instructor for grading.

### LAP JOINT

1. Lower the helmet. Tack weld two pieces of mild steel together to form a lap joint. "Cover" should be said before striking an arc.
2. Position the metal so that the joint to be welded will be in flat position.
3. The electrode should be held at a 45 degree angle to the surface of the weld and pointed forward at approximately 70 to 80 degrees from the weld axis. The filler rod is held at a 15 to 20 degree angle to the plate.
4. Lower the helmet and strike the arc.
5. Move the filler rod into the leading edge of the molten puddle and let a drop or two of molten filler metal fill the puddle.
6. Withdraw the filler rod about 1/2 inch from the arc so the torch and puddle can be moved in the direction of travel; be sure to keep the end of the rod in the shielded area.
7. Advance the puddle while using the torch to maintain a uniform bead width. Then reinsert the filler rod into the center of the molten puddle at the point of the arc; let a drop or two of molten filler metal fill the puddle.
8. Repeat the procedure until the weld is complete.
9. Stop just as you reach the end of the plate and let off the foot control. Keep the torch in place for a few seconds after the end of the weld.
10. Examine the weld for penetration and bead appearance.
11. Turn in the weld to the instructor for grading.

### T-FILLET JOINT

1. Lower the helmet. Tack weld two pieces of mild steel together to form a T joint. "Cover" should be said before striking an arc.
2. Position the metal so that the joint to be welded will be in flat position.
3. The electrode should be held at a 45 degree angle to the surface of the weld and pointed forward at approximately 70 to 80 degrees from the weld axis. The filler rod is held at a 15 to 20 degree angle to the plate.
4. Lower the helmet and strike the arc.
5. Move the filler rod into the leading edge of the molten puddle and let a drop or two of molten filler metal fill the puddle.
6. Withdraw the filler rod about 1/2 inch from the arc so the torch and puddle can be moved in the direction of travel; be sure to keep the end of the rod in the shielded area.

7. Advance the puddle while using the torch to maintain a uniform bead width. Then reinsert the filler rod into the center of the molten puddle at the point of the arc; let a drop or two of molten filler metal fill the puddle.
8. Repeat the procedure until the weld is complete.
9. Stop just as you reach the end of the plate and let off the foot control. Keep the torch in place for a few seconds after the end of the weld.
10. Examine the weld for penetration and bead appearance.
11. Turn in the weld to the instructor for grading.

### **Postwelding Procedure**

Refer to JS 3.1 for postwelding procedures.



## UNIT III -ARC WELDING

### Job Sheet 3.3: Welds in the Horizontal Position

#### Objective

At the completion of this job sheet, the student will be able to perform a butt, lap, and T-fillet weld in the horizontal position using a GTAW welder.

#### Tools and Equipment Needed

1. GTAW machine and accessories
2. Protective clothing
3. Safety goggles\*
4. Helmet
5. Adjustable wrench or appropriate open-end wrench
6. Shielding gas cylinder
7. Tungsten
8. Pliers

\* CAUTION: Everyone participating in or observing the procedure should wear appropriate protective eyewear. Safety precautions must be observed while in the shop area.

#### Materials Needed

1. Filler metal - per instructor
2. Mild steel plates - size to be determined by the instructor

#### Prewelding Procedure

Refer to JS 3.1 for prewelding procedures needed to prepare for horizontal position welding.

#### Welding Procedure

##### BUTT JOINT

1. Lower the helmet. Tack weld two pieces of mild steel together to form a butt joint. "Cover" should be said before striking an arc. If the metal is thicker than 1/8 inch, the edges of the joint should be beveled to increase penetration. A space, approximately 1/16 inch, should be left between the metal plates to increase penetration of the weld.
2. Position the metal so that the joint to be welded will be in the horizontal position.
3. The torch should be held 75 to 80 degrees to the surface of the weld and the back of the torch should be tipped downward so that the electrode is pointing up toward the weld at a 15 degree angle. The filler rod is held at a 20 degree angle to the plate.
4. Lower the helmet and strike the arc.

## Agricultural Construction

---

5. Move the filler rod into the leading edge of the molten puddle and let a drop or two of molten filler metal fill the puddle.
6. Withdraw the filler rod about 1/2 inch from the arc so the torch and puddle can be moved in the direction of travel; be sure to keep the end of the rod in the shielded area.
7. Advance the puddle while using the torch to maintain a uniform bead width. Then reinsert the filler rod into the center of the molten puddle at the point of the arc; let a drop or two of molten filler metal fill the puddle.
8. Repeat the procedure until the weld is complete.
9. Stop just as you reach the end of the plate and let off the foot control. Keep the torch in place for a few seconds after the end of the weld.
10. Examine the weld for penetration and bead appearance.
11. Turn in the weld to the instructor for grading.

### LAP JOINT

1. Lower the helmet. Tack weld two pieces of mild steel together to form a lap joint. "Cover" should be said before striking an arc.
2. Position the metal so that the joint to be welded will be in the horizontal position.
3. The electrode should be held 45 degrees to the surface of the weld and pointed forward at 70 to 80 degrees from the weld axis. The filler rod is held at a 20 degree angle to the plate.
4. Lower the helmet and strike the arc.
5. Move the filler rod into the leading edge of the molten puddle and let a drop or two of molten filler metal fill the puddle.
6. Withdraw the filler rod about 1/2 inch from the arc so the torch and puddle can be moved in the direction of travel; be sure to keep the end of the rod in the shielded area.
7. Advance the puddle while using the torch to maintain a uniform bead width. Then reinsert the filler rod into the center of the molten puddle at the point of the arc; let a drop or two of molten filler metal fill the puddle.
8. Repeat the procedure until the weld is complete.
9. Stop just as you reach the end of the plate and let off the foot control. Keep the torch in place for a few seconds after the end of the weld.
10. Examine the weld for penetration and bead appearance.
11. Turn in the weld to the instructor for grading.

### T-FILLET JOINT

1. Lower the helmet. Tack weld two pieces of mild steel together to form a T joint. "Cover" should be said before striking an arc.
2. Position the metal so that the joint to be welded will be in the horizontal position.
3. The electrode should be held 45 degrees to the surface of the weld and pointed forward at 70 to 80 degrees from the weld axis. The filler rod is held at a 15 to 20 degree angle to the plate.
4. Lower the helmet and strike the arc.
5. Move the filler rod into the leading edge of the molten puddle and let a drop or two of molten filler metal fill the puddle.
6. Withdraw the filler rod about 1/2 inch from the arc so the torch and puddle can be moved in the direction of travel; be sure to keep the end of the rod in the shielded area.



7. Advance the puddle while using the torch to maintain a uniform bead width. Then reinsert the filler rod into the center of the molten puddle at the point of the arc; let a drop or two of molten filler metal fill the puddle.
8. Repeat the procedure until the weld is complete.
9. Stop just as you reach the end of the plate and let off the foot control. Keep the torch in place for a few seconds after the end of the weld.
10. Examine the weld for penetration and bead appearance.
11. Turn in the weld to the instructor for grading.

### **Postwelding Procedure**

Refer to JS 3.1 for postwelding procedures.



## UNIT III - ARC WELDING

### Job Sheet 3.4: Welds in the Vertical Position

#### Objective

At the completion of this job sheet, the student will be able to perform a butt, lap, and T-fillet weld in the vertical position using a GTAW welder.

#### Tools and Equipment Needed

1. GTAW machine and accessories
2. Protective clothing
3. Safety goggles\*
4. Helmet
5. Adjustable wrench or appropriate open-end wrench
6. Shielding gas cylinder
7. Tungsten
8. Pliers

\* CAUTION: Everyone participating in or observing the procedure should wear appropriate protective eyewear. Safety precautions must be observed while in the shop area.

#### Materials Needed

1. Filler metal - per instructor
2. Mild steel plates - size to be determined by the instructor

#### Prewelding Procedure

Refer to JS 3.1 for prewelding procedures.

#### Welding Procedure

##### BUTT JOINT

1. Lower the helmet. Tack weld two pieces of mild steel together to form a butt joint. "Cover" should be said before striking an arc. If the metal is thicker than 1/8 inch, the edges of the joint should be beveled to increase penetration. A space, approximately 1/16 inch, should be left between the metal plates to increase penetration of the weld.
2. Position the metal so that the joint to be welded will be in the vertical position. For thicker metal, it is best to weld with the weld pool moving from the bottom to the top, or vertically up. For thinner metal, it is best to weld with the pool moving from the top to the bottom, or vertically down.
3. The torch should be held perpendicular to the surface of the weld and tipped down so that the torch is 75 to 80 degrees from the base metal. The filler rod is held at an angle of approximately 35 to 45 degrees to the plate.

## Agricultural Construction

---

4. Lower the helmet and strike the arc.
5. Move the filler rod into the leading edge of the molten puddle and let a drop or two of molten filler metal fill the puddle.
6. Withdraw the filler rod about 1/2 inch from the arc so the torch and puddle can be moved in the direction of travel; be sure to keep the end of the rod in the shielded area.
7. Advance the puddle while using the torch to maintain a uniform bead width. Then reinsert the filler rod into the center of the molten puddle at the point of the arc; let a drop or two of molten filler metal fill the puddle.
8. Repeat the procedure until the weld is complete.
9. Stop just as you reach the end of the plate and let off the foot control. Keep the torch in place for a few seconds after the end of the weld.
10. Examine the weld for penetration and bead appearance.
11. Turn in weld to the instructor for grading.

### LAP JOINT

1. Lower the helmet. Tack weld two pieces of mild steel together to form a lap joint. "Cover" should be said before striking an arc.
2. Position the metal so that the joint to be welded will be in the vertical position. For thicker metal, it is best to weld with the weld pool moving from the bottom to the top, or vertically up. For thinner metal, it is best to weld with the pool moving from the top to the bottom, or vertically down.
3. The torch should be centered over the root of the weld and tipped down so that the torch is 75 to 80 degrees from the base metal. The filler rod is held at an angle of approximately 35 to 45 degrees to the plate.
4. Lower the helmet and strike the arc.
5. Move the filler rod into the leading edge of the molten puddle and let a drop or two of molten filler metal fill the puddle.
6. Withdraw the filler rod about 1/2 inch from the arc so the torch and puddle can be moved in the direction of travel; be sure to keep the end of the rod in the shielded area.
7. Advance the puddle while using the torch to maintain a uniform bead width. Then reinsert the filler rod into the center of the molten puddle at the point of the arc; let a drop or two of molten filler metal fill the puddle.
8. Repeat the procedure until the weld is complete.
9. Stop just as you reach the end of the plate and let off the foot control. Keep the torch in place for a few seconds after the end of the weld.
10. Examine the weld for penetration and bead appearance.
11. Turn in weld to the instructor for grading.

### T-FILLET JOINT

1. Lower the helmet. Tack weld two pieces of mild steel together to form a T joint. "Cover" should be said before striking an arc.
2. Position the metal so that the joint to be welded will be in the vertical position. For thicker metal, it is best to weld with the weld pool moving from the bottom to the top, or vertically up. For thinner metal, it is best to weld with the pool moving from the top to the bottom, or vertically down.
3. The torch should be centered over the root of the weld and tipped down so that the torch is 75 to 80 degrees from the base metal. The filler rod is held at an angle of approximately 35 to 45 degrees to the plate.

4. Lower the helmet and strike the arc.
5. Move the filler rod into the leading edge of the molten puddle and let a drop or two of molten filler metal fill the puddle.
6. Withdraw the filler rod about 1/2 inch from the arc so the torch and puddle can be moved in the direction of travel; be sure to keep the end of the rod in the shielded area.
7. Advance the puddle while using the torch to maintain a uniform bead width. Then reinsert the filler rod into the center of the molten puddle at the point of the arc; let a drop or two of molten filler metal fill the puddle.
8. Repeat the procedure until the weld is complete.
9. Stop just as you reach the end of the plate and let off the foot control. Keep the torch in place for a few seconds after the end of the weld.
10. Examine the weld for penetration and bead appearance.
11. Turn in weld to the instructor for grading.

### **Postwelding Procedure**

Refer to JS 3.1 for postwelding procedures.



## UNIT III - ARC WELDING

### Job Sheet 3.5: Welds in the Overhead Position

#### Objective

At the completion of this job sheet, the student will be able to perform a butt, lap, and T-fillet weld in the overhead position using a GTAW welder.

#### Tools and Equipment Needed

1. GTAW machine and accessories
2. Protective clothing
3. Safety goggles\*
4. Helmet
5. Adjustable wrench or appropriate open-end wrench
6. Shielding gas cylinder
7. Tungsten
8. Pliers

\* CAUTION: Everyone participating in or observing the procedure should wear appropriate protective eyewear. Safety precautions must be observed while in the shop area.

#### Materials Needed

1. Filler metal - per instructor
2. Mild steel plates - size to be determined by the instructor

#### Prewelding Procedure

Refer to JS 3.1 for prewelding procedures.

#### Welding Procedure:

##### BUTT JOINT

1. Lower the helmet. Tack weld two pieces of mild steel together to form a butt joint. "Cover" should be said before striking an arc. If the metal is thicker than 1/8 inch, the edges of the joint should be beveled to increase penetration. A space, approximately 1/16 inch, should be left between the metal plates to increase penetration of the weld.
2. Position the metal so that the joint to be welded will be in the overhead position.
3. The electrode should be perpendicular to the surface of the weld and pointed forward with the torch approximately 70 to 80 degrees from the weld axis. The filler rod is held at a 15 to 20 degree angle to the plate.
4. Lower the helmet and strike the arc.

## Agricultural Construction

---

5. Move the filler rod into the leading edge of the molten puddle and let a drop or two of molten filler metal fill the puddle.
6. Withdraw the filler rod about 1/2 inch from the arc so the torch and puddle can be moved in the direction of travel; be sure to keep the end of the rod in the shielded area.
7. Advance the puddle while using the torch to maintain a uniform bead width. Then reinsert the filler rod into the center of the molten puddle at the point of the arc; let a drop or two of molten filler metal fill the puddle.
8. Repeat the procedure until the weld is complete.
9. Stop just as you reach the end of the plate and let off the foot control. Keep the torch in place for a few seconds after the end of the weld.
10. Examine the weld for penetration and bead appearance.
11. Turn in weld to the instructor for grading.

### LAP JOINT

1. Lower the helmet. Tack weld two pieces of mild steel together to form a lap joint. “Cover” should be said before striking an arc. If the metal is thicker than 1/8 inch, the edges of the joint should be beveled to increase penetration.
2. Position the metal so that the joint to be welded will be in the overhead position.
3. The electrode should be held at a 45 degree angle to the surface of the weld and pointed forward at approximately 70 to 80 degrees from the weld axis. The filler rod is held at a 15 to 20 degree angle to the plate.
4. Lower the helmet and strike the arc.
5. Move the filler rod into the leading edge of the molten puddle and let a drop or two of molten filler metal fill the puddle.
6. Withdraw the filler rod about 1/2 inch from the arc so the torch and puddle can be moved in the direction of travel; be sure to keep the end of the rod in the shielded area.
7. Advance the puddle while using the torch to maintain a uniform bead width. Then reinsert the filler rod into the center of the molten puddle at the point of the arc; let a drop or two of molten filler metal fill the puddle.
8. Repeat the procedure until the weld is complete.
9. Stop just as you reach the end of the plate and let off the foot control. Keep the torch in place for a few seconds after the end of the weld.
10. Examine the weld for penetration and bead appearance.
11. Turn in the weld to the instructor for grading.

### T-FILLET JOINT

1. Lower the helmet. Tack weld two pieces of mild steel together to form a T joint. “Cover” should be said before striking an arc.
2. Position the metal so that the joint to be welded will be in the overhead position.
3. The electrode should be held at a 45 degree angle to the surface of the weld and pointed forward at approximately 70 to 80 degrees from the weld axis. The filler rod is held at a 15 to 20 degree angle to the plate.
4. Lower the helmet and strike the arc.
5. Move the filler rod into the leading edge of the molten puddle and let a drop or two of molten filler metal fill the puddle.



6. Withdraw the filler rod about 1/2 inch from the arc so the torch and puddle can be moved in the direction of travel; be sure to keep the end of the rod in the shielded area.
7. Advance the puddle while using the torch to maintain a uniform bead width. Then reinsert the filler rod into the center of the molten puddle at the point of the arc; let a drop or two of molten filler metal fill the puddle.
8. Repeat the procedure until the weld is complete.
9. Stop just as you reach the end of the plate and let off the foot control. Keep the torch in place for a few seconds after the end of the weld.
10. Examine the weld for penetration and bead appearance.
11. Turn in weld to the instructor for grading.

### Postwelding Procedure

Refer to JS 3.1 for postwelding procedures.