

AGRICULTURAL STRUCTURES

Writers:

Claude Busby, Brad King, and James C. Graham
Instructional Materials Laboratory
University of Missouri-Columbia

Consulting Editor:

Jim Riley
Agricultural Education
University of Missouri-Columbia

Sherry Mahnken, Editor

Instructional Materials Laboratory
University of Missouri-Columbia

Produced by:

Instructional Materials Laboratory
University of Missouri-Columbia
10 London Hall
Columbia, Missouri 65211

Volume 31
Number 2

Catalog Number 10-7103-S
June 1999

Available from:
Instructional Materials Laboratory
University of Missouri-Columbia
10 London Hall
Columbia, MO 65211
573-882-2883

©1999 the Curators of the University of Missouri on behalf of the Missouri Department of Elementary and Secondary Education. All rights reserved.

The activity that is the subject of this report was supported in whole or in part by funds from the Department of Elementary and Secondary Education, Division of Vocational and Adult Education. However, the opinions expressed herein do not necessarily reflect the position or policies of the Missouri Department of Elementary and Secondary Education or the Division of Vocational and Adult Education, and no official endorsement should be inferred.

ACKNOWLEDGMENTS

Recognition is given to advisory committee members for providing their valuable time and suggestions in developing this agricultural structures curriculum. The committee consisted of Gale Hodges, Doyle Justus, Keith Mueller, Mike Pollard, Alan Slayton, Kirk Lawson, Lance Massey, Joseph Zulovich, and Charles Parkes.

Information for this project was supplied by individuals at J&B Construction in Gallatin, Missouri; Weston Drilling and Pump Co. in New Franklin, Missouri; and Ballenger's Propane Service in Columbia, Missouri.

Appreciation is expressed to the following staff members of the Instructional Materials Laboratory for their efforts in producing this material: Dana Tannehill, Director; Dan Stapleton, Associate Director; Veronica Feilner, Project Coordinator; Bonnie Painter, Assistant Editor; Cheryl Unterschut, Graphic Designer; Kevin Gamble, Graphic Artist; Chris Casey, Graphic Artist; and Jill Clark, Jamie Keith, and Allison Cadle, Editorial Assistants.

Sherry Mahnken, Editor
Instructional Materials Laboratory
University of Missouri-Columbia

Jim Riley, Instructor
Agricultural Education
University of Missouri-Columbia

FOREWORD

The development of the *Agricultural Structures* curriculum guide is the result of suggestions by the MVATA Teaching Aids Committee. The Agricultural Structures Advisory Committee suggested the topics to be included and reviewed the materials.

This curriculum contains seven units. Topics include working with plans, home and farmstead planning, building construction, concrete, electricity, plumbing, and fencing. An instructor guide can be purchased separately.

During the summer of 1981, the Missouri State Board of Education formally adopted the concept of "Instructional Management Systems" (IMS) as a priority for the 1981-82 school year. The Missouri Commissioner of Education described the IMS concept as a practical way of "organizing for excellence" in education. To meet the demand for greater productivity and accountability, the director of Vocational Education applied the elements of IMS to form the Vocational Instructional Management System (VIMS). The VIMS process provides a framework to use in planning and organizing to assure excellence in Missouri's vocational education system by focusing greater attention on the management of teaching and learning. The instructor guide for this student reference incorporates the needed component parts to aid agriculture teachers in the implementation of VIMS.

Jim Riley, Instructor
Agricultural Education
University of Missouri-Columbia

Terry Heiman, Director
Agricultural Education
Department of Elementary and
Secondary Education

AGRICULTURAL STRUCTURES

TABLE OF CONTENTS

ACKNOWLEDGMENTS.....	iii
FOREWORD.....	iv
UNIT I - WORKING WITH PLANS	
Lesson 1--Preparing a Plan.....	I-1
Lesson 2--Understanding a Plan of Procedure.....	I-7
UNIT II - HOME AND FARMSTEAD PLANNING	
Lesson 1--Home Site Selection.....	II-1
Lesson 2--Arranging a Farmstead.....	II-5
Lesson 3--Livestock Manure Management Systems.....	II-9
UNIT III - BUILDING CONSTRUCTION	
Lesson 1--Construction Safety.....	III-1
Lesson 2--Building Designs.....	III-3
Lesson 3--Building Materials.....	III-7
Lesson 4--Fasteners and Fastening Systems.....	III-11
Lesson 5--Floors and Subfloors.....	III-17
Lesson 6--Walls.....	III-21
Lesson 7--Roof Support Systems.....	III-25
Lesson 8--Roofing Materials.....	III-31
Lesson 9--Heating, Cooling, and Ventilation.....	III-37
UNIT IV - CONCRETE	
Lesson 1--Safety in Working with Concrete.....	IV-1
Lesson 2--Factors Affecting the Quality of Fresh Concrete.....	IV-3
Lesson 3--Site Preparation.....	IV-7
Lesson 4--Pouring a Concrete Slab.....	IV-11
Lesson 5--Ordering, Pouring, and Finishing Concrete.....	IV-15
Lesson 6--Curing Concrete.....	IV-19
Lesson 7--Pouring Concrete Walls.....	IV-23
UNIT V - ELECTRICITY	
Lesson 1--Electrical Safety.....	V-1
Lesson 2--Electrical Terminology.....	V-5
Lesson 3--Wire Types and Uses.....	V-7
Lesson 4--Grounding and GFCI Protection.....	V-15
Lesson 5--Lights, Outlets, Switches, and Circuit Protection.....	V-19
Lesson 6--Electrical Symbols in Wiring Plans.....	V-23
Lesson 7--Running Electrical Wiring.....	V-25
Lesson 8--Connecting to the SEP.....	V-29
Lesson 9--Running Wire from the SEP.....	V-35
Lesson 10--Cost and Electrical Power Use.....	V-43
Lesson 11--Lightning Protection.....	V-45
Lesson 12--Detecting Problems.....	V-51
UNIT VI - PLUMBING	
Lesson 1--Water Needs.....	VI-1

Lesson 2--Plumbing Safety	VI-3
Lesson 3--Pipe Types and Size Requirements	VI-5
Lesson 4--Measuring, Cutting, and Connecting Pipes	VI-9
Lesson 5--Protecting Water Pipes from Freezing	VI-13

UNIT VII - FENCING

Lesson 1--Fencing Basics	VII-1
Lesson 2--Setting and Bracing Posts	VII-5
Lesson 3--Barbed and Woven Wire Fences	VII-11
Lesson 4--High Tensile and Electric Fences	VII-17
Lesson 5--Fence Mending Techniques	VII-23

GLOSSARY.....	Glossary-1
---------------	------------

Lesson 1: Preparing a Plan

When building an agricultural structure, developing and understanding a simple construction drawing is the first step in actually producing the structure. The following lesson will outline the importance of developing a useable plan and explain how to develop a simple plan.

The Importance of Having a Good Plan

A plan is a drawing of a proposed structure containing a pictorial representation of the structure and information about it, such as the various dimensions of the structure and the placement of any doors or windows. Having and following a good plan will provide a useable structure that serves its intended purpose. A good plan will be well thought out before the actual building of the structure begins, thus providing an opportunity to design the structure to meet specific needs. Following a good plan saves time and money and allows an individual to avoid the difficulties associated with situations caused by a lack of careful forethought. A good plan is the builder's instruction sheet!

The Steps in Making a Good Plan

The first step in making a good plan is determining and defining needs. Being as specific as possible is important to avoid problems with the plan later. The person planning the structure should ask himself or herself, "What are the intended uses of the structure?" As she or he considers the uses of the structure, this information should be written down and reviewed carefully. For example, suppose storage space was needed for lawn and garden equipment, so a storage shed was to be built. The person putting together the plan would need to make the storage shed as usable as possible. A good place to start would be to write down a list of the items that would be stored there.

The next step is to determine the size of the structure. The designer should consider what size the structure needs to be to fulfill its intended purpose. Forethought is required at this point in the plan. Defining the needs is first evaluated by determining what the building is to

- Building and fire codes - These codes provide a list of rules and regulations

be used for and considering any needs that might be designated in the future. Also, consideration must be given in order to have enough room in the structure for access and maneuvering. For this project, a storage shed with floor dimensions of 10 feet by 14 feet, equaling 140 square feet of floor space, should be sufficient for storing a riding lawn mower with a width of 42 inches, a wheelbarrow, and many hand tools and supplies. A door 48 inches wide and 80 inches tall centered in the front of the building would allow good entry for the equipment. Walls should be 8 feet in height with an overall building height of 18 feet from the ridge of the roof to the bottom of the structure.

The third step is to choose the style of the structure. Different styles and combinations of styles allow for a wide selection of structures. Structures are often referred to by their shape or roof style. Some examples of basic shapes are round, dome, A-frame, square, or rectangular. Common roof styles are gambrel, gable, or a shed roof. These roof types will be discussed in more detail in later lessons. For the storage shed described in the preceding paragraphs, a gambrel roof would be a good choice. This style will allow for considerable overhead room that can be used for storage if needed.

While other factors to think about at this point in the planning process will not affect all structures, they may be considerations in certain circumstances. An individual planning a building may need to consider the following factors:

- Material resources available - Some materials may be more cost efficient or easier to work with in construction but are simply not available or would take too long to find and purchase. An excellent example is very long pieces of dimensional lumber. Sixteen-foot lengths are not available in all dimensions on a regular basis; longer lengths may be very hard to obtain.
- Cost factors and constraints - Cost is usually a limiting factor in construction. Projects must be constructed at a cost that will allow for their completion and use.

that must be followed when planning and constructing a building. The

Working with Plans

regulations do not just apply to residential buildings, but to most structures. Compliance with any code or regulation in effect for a structure makes good sense. They are designed to ensure structures are safe. Insurance companies may also reject insurance applications or certain claims on buildings that are not in compliance.

- Zoning laws - Zoning laws are a set of local restrictions and requirements that determine what type of building may be done in a particular area. These laws regulate the type of building permitted, the size of a structure, the permits required, the style of construction, and other characteristics.
- Insurance and/or financial stipulations - These stipulations can affect the style and size of building that a lending institution will approve for financing. If commercial financing by a bank or other lending agency is required for the project, insurance is commonly required also.
- Safety considerations for specific structures - Structures may have very specific safety concerns, which generally depend on the enterprise in question. Ventilation could be a serious safety consideration, as a repair shop where engine exhaust or fumes might build up to dangerous levels. Milking parlors that are washed down daily may have slick floors if special measures are not included in the plan before construction begins. Hay and grain storage facilities have specific fire precautions that need to be addressed before construction.
- Utility and service access - Any enterprise will need some level of utility and service access to structures, and some need very reliable access. A good example is dairies where milk must be picked up on a regular basis.
- Cleaning requirements - For some enterprises, such as dairies and pig nurseries, cleaning is an everyday practice. Drains and sufficient water supplies must be planned to operate efficiently.
- Heating and cooling requirements - These requirements are critical to some enterprises, such as greenhouses or livestock and poultry facilities. They

must be planned before beginning to build a structure.

Notice how quickly details accumulate when putting together a plan. Even a simple drawing must convey a large amount of information. A simple construction drawing for the storage building described could be put together from the information given above. However, before the plan could actually be drawn, an understanding of scale and the symbols used on plans is necessary.

Scale

According to Webster's Dictionary, scale means "a proportion between two sets of dimensions." For plans, scale indicates an adjustment in the size of a drawing that reflects the size of the object being drawn. Drawing structures to their actual size on paper would not be practical. A system of reducing the actual size mathematically has been devised to compensate and allow for easy drawing and interpretation. An example would be to draw a construction project to 1/48 of the actual size, with one foot of the actual project being represented by 1/4 inch on the drawing. This scale would be indicated on the drawing by including the following label: Scale 1/4 inch = 1 foot.

Some common scales are used to represent projects of different sizes. Although many different scales can be used, the chart in Table 1.1 shows several of the most common scales. They are found on a triangular architect's scale (see Figure 1.1), a tool used by professionals who do many construction drawings. The architect's scale combines the eleven commonly used scales on one tool. Two scales are found on each face. The

Table 1.1 - Common Scales

Full Scale

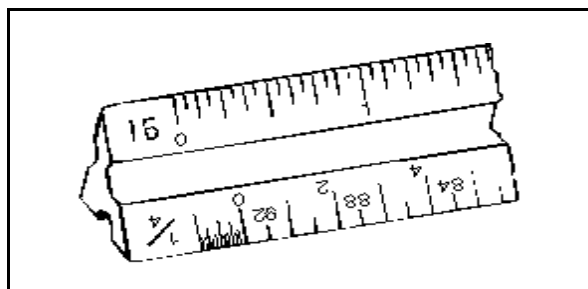

Lesson 1: Preparing a Plan

$3/32" = 1'$	$1/16" = 1'$
$3/16" = 1'$	$1/4" = 1'$
$1/2" = 1'$	$1/2" = 1'$

$3/4" = 1'$	$1" = 1'$
$1 1/2" = 1'$	$3" = 1'$

main units of the scales are undivided with a fully subdivided extra unit at the zero end; the only exception is the full size scale, which is divided into sixteenths. The numbers listed at the zero end represent the length in inches that will represent one foot of the actual structure being drawn. This tool is very convenient for anyone drawing by hand. However, a regular ruler may also be used to draw a simple plan to scale.

When using a regular ruler, consider the maximum amount of space available for drawing. If standard drawing paper is used, as shown in Figure 1.2, approximately 10 inches by 7 inches is available for the drawing. Then consider the

size of the actual structure. The storage building described in the earlier example has a 10 foot by 14-foot floor. To draw this structure on a standard sheet of drawing paper, the scale must fit a length of 10 inches and a width of 7 inches. The scale must fit within 7 inches, since this measurement is the limiting dimension for the drawing. What is needed is a scale that represents 14 feet in no more than 7 inches of drawing space. Keep the math simple and estimate a scale that might work. If the scale $1/2$ inch = 1 foot is used, 7 inches on the drawing will represent 14 feet of the actual structure.

Common Symbols and Elements of a

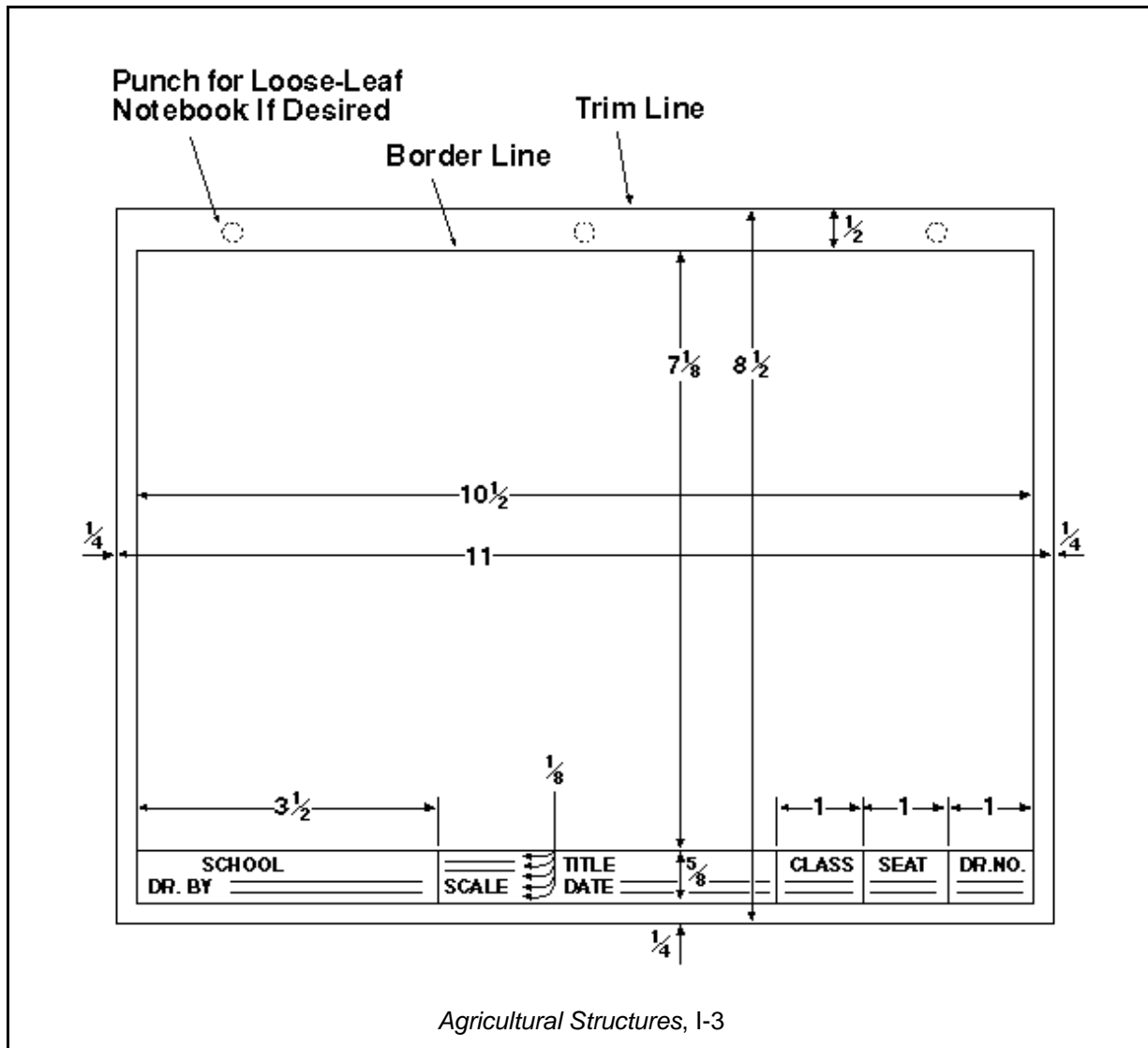

Working with Plans

Plan

Elements are the different parts of a construction drawing that convey information or enhance the information displayed on the drawing. Examples of elements would be all the information in the blocks provided in the title box, such as the name

Working with Plans

of the person drawing the plan, title of the project, date, and scale (see Figure 1.2), as well as the symbols found on the drawing. The lines used for the drawing are also elements of a plan.

Symbols are pictorial representations of information that are included on the actual drawing. Some symbols, such as those for doors and windows, may be subject to the same scale as the rest of the drawing. They show the location of these parts of the structure. Other symbols, such as those used for plumbing and electricity, show where these devices or appliances are to be located. Symbols may also indicate the type or grade of materials used, such as concrete, steel, or wood.

The symbols that can be included on a plan cover a large number of pictorial representations of items that should be shown but are not practical to draw. As the illustration of symbols shown in Figure 1.3 indicates, they can be broken into categories, such as electrical symbols, plumbing symbols, symbols for metals, and symbols for lumber.

Symbols are most often used on plans to represent specific types of materials, doors, windows, and electrical or plumbing apparatuses.

They need to appear on the plan where the specific information they convey is important. The appearance of symbols may vary between different sources, but they generally are like the examples in the illustration or are similar enough to be recognizable. Symbols are a great convenience for displaying information. The information conveyed by most symbols is more often of use on detailed plans. These symbols may appear on simple construction drawings if they are needed to represent specific information related to a particular plan.

Several different types of lines (Figure 1.4) may be used on a plan. As with the symbols, using all these lines on a single project is unlikely, but each may convey information needed for a specific project.

- **Border line** - A border line is the heavy dark line around the perimeter of the drawing paper, usually $\frac{1}{4}$ inch from the paper's edge. The drawing and all other information are inside the border line.

- **Object line** - This line is a very distinct line used to draw the object.
- **Hidden line** - A hidden line is a dashed line that represents material in a drawing that is under other material from the view being displayed.
- **Extension line** - This type of line is used for placing dimensions on drawings. It extends from objects without touching them to indicate their length, width, and height.
- **Dimension line** - This line shows the size of an object. It spans the space from one extension line to the next and has arrows at each end; a numerical notation of the length is displayed in a broken area in the middle of the line.
- **Break line** - A break line represents an area in a structure where a section has been removed.

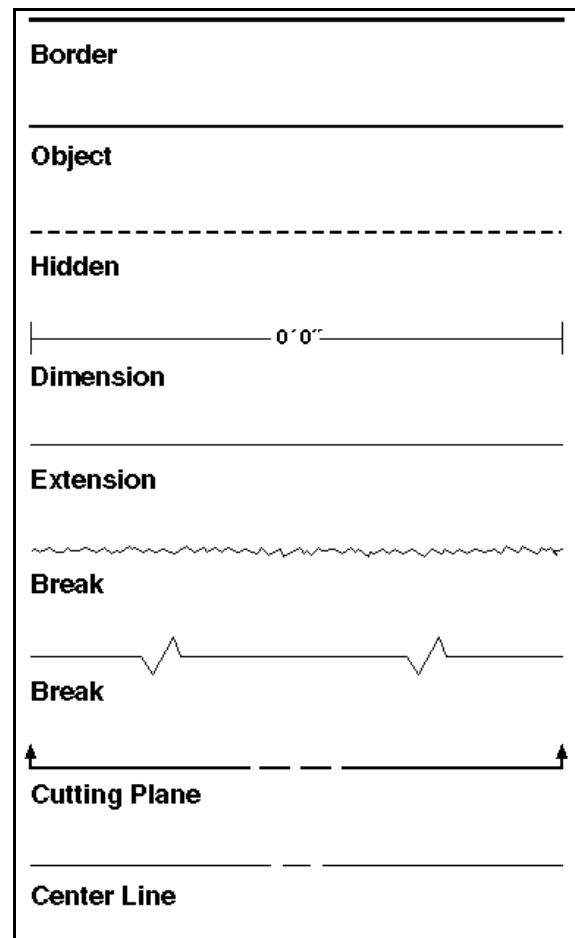

- **Cutting plane** - A cutting plane shows an area where a section has been removed.

Arrows on the end show the direction from which the section was taken.

- **Center line** - A center line shows the centers of holes and round shapes, such as drains.

Elevation drawing is a term used by drafters to refer to orthographic projections of a structure as viewed from different perspectives, most commonly the top, front, and one or both sides. Drawing only one view simply does not provide enough information to be able to visualize the structure completely. To convey the necessary basic information about a structure, a minimum of three elevation drawings must be produced either by hand or with a CAD system. These drawings show the exterior features of the

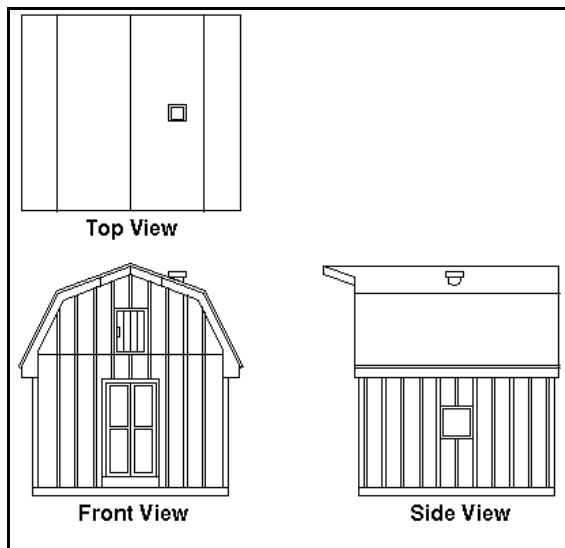

building. Figure 1.5 shows different elevation drawings for a particular structure.

Computer-Aided Drafting

Computer-aided drafting or design, called CAD, is a system consisting of a computer and specially designed software that does the actual drawing of plans. CAD software programs are offered in different levels of complexity as well as in home versions that are inexpensive and produce excellent results. CAD is now the industry standard for drafting. The four main

benefits of CAD over conventional hand drafting are speed, quality, ease of making changes, and communication (since CAD drawings can be transferred electronically). Drafting complex plans was once very labor intensive but can now be done with less effort. Changes can be made and viewed easily before printing. However, the CAD operator must still have the skill and talent to develop a functional plan. Many schools now teach the use of CAD.

Summary

As demonstrated throughout the lesson, the plan affects how the structure ultimately looks. To formulate and produce a good plan, the structure's intended purpose must be carefully considered. Decisions on style and size are determined by evaluating all known facts concerning the proposed structure. Each structure will likely have its own unique circumstances and considerations that factor into the plan. To convey the necessary information, a minimum of three elevation drawings of the structure must be produced either by hand or with a CAD system.

Credits

Duelm, Brian L. *Computer-Aided Drafting*. Holland, Ill.: Goodheart-Willcox Company, Inc., 1989.

Huth, Mark W. *Construction Technology*. 2nd ed. Albany, N.Y.: Delmar Publishers, Inc., 1989.

McClain, Gerald R. *Basic Drafting*. 3rd ed. Stillwater, Okla.: MAVCC, 1997.

National Plan Service. *UCANDO Design #B2042*. 1994.

Lesson 2: Understanding a Plan of Procedure

Lesson 2: Understanding a Plan of Procedure

This lesson will provide information about how to develop a plan of procedure and produce material lists, also called bills of materials. Different types of material lists and their uses will also be explored.

Steps in Making a Plan of Procedure

A plan of procedure is the order in which everything concerning the eventual completion of a planned project is identified, listed, and then arranged in a logical order from the first step to the last step. A good place to start is with a review of the printed construction plan. From this, the exact material requirements can be determined.

A good plan will need to follow a logical order suitable for the project. The first step in developing a plan of procedure is identifying every factor that may affect the project and then arranging all the identified elements in a logical order. With some projects, this process may be lengthy. Factors such as code specifications, site, financing stipulations, and insurance requirements can affect some plans of procedure. More complicated structures might require extensive site preparation before construction of the foundation, or perhaps utilities must be placed before concrete is poured. A variety of circumstances and situations may need to be considered. A good plan requires careful attention and forethought. Visualizing and writing out each step of the project's construction can be of value in formulating a plan.

The second step in developing a plan of procedure is considering the type and grade of materials appropriate for the project. Each project may have unique circumstances that might influence these choices. The person doing the planning must evaluate the purpose of the structure and select materials with this information in mind. Other factors to be considered are resources and their availability. Materials come in a variety of grades of quality, each of which is suited to a specific set of circumstances. Retailers of specific products are knowledgeable and can be of help in selecting materials for construction.

The third step in the planning process is putting together a list of the materials required. This type of list is called a bill of materials. This list will need to be developed from the information assembled so far and by studying the plan drawings.

The final step involves the purchase of materials and the assembly of the structure. After the needed materials have been bought, any necessary cutting of the materials is done. The project can then be assembled in a logical order.

The Importance of a Bill of Materials

A bill of materials is a list of all the components included in a proposed project. The materials need to be identified by amount, size, and kind. Also, for convenience, they are usually separated into broad categories of supplies, such as lumber, plumbing materials, electrical materials, etc. These lists are necessary for purchasing the correct amount of materials and for obtaining cost estimates. For projects requiring a significant amount of materials, a common practice is to submit a bill of materials to different suppliers and receive quotes on the exact cost from each supplier. These estimates can vary considerably.

Cutting and Purchasing Bills of Materials

Bills of materials are often divided into two types of lists, a cutting bill of materials and a purchasing bill of materials. Many materials used in construction of agriculture structures come from suppliers in standard sizes and dimensions, particularly plumbing supplies and lumber. These standard sizes make it necessary to purchase more material than will be used in the project. The materials are then cut to the exact dimensions needed during construction. Careful consideration must be given to the purchase of materials to minimize waste and keep costs as low as possible.

A cutting bill of materials is a list of all the materials, in the actual sizes or dimensions needed, that will need to be cut to size during the construction of the project. For most projects, depending on the material type and size of the project, the cutting list is developed before the purchasing list to reduce waste when purchasing materials.

Working with Plans

The purchasing bill of materials can be developed from the information identified in the cutting bill of materials and from the drawings of a structure. This list should include the materials identified on the cutting bill of materials in their standard sizes. It will also list all other materials needed to construct the project, such as fasteners, hinges, wire, etc.

The following example illustrates developing a plan of procedure with a cutting and purchasing bill of materials. The selected example is a sawhorse, illustrated in Figure 2.1. Developing a plan of procedure involves first studying the elevation drawings and noting the dimension lines to determine the details of the project.

As noted on the drawings, the project consists of 2" x 4" boards in different lengths, two sections of 1" x 6" board, and screws for fasteners. Wood is the material used for this project. The next step of the process is to inventory the parts of the project and develop a cutting bill of materials.

Inventory:

inch section left over. The end braces consist of 1" x 6" lumber, and although a total of only 22 inches is required for the project, the purchase of a standard 8-foot board will usually be necessary.

The remainder, a section 74 inches in length, can be used for a future project. Wood screws will be used to assemble this project, requiring eight 3-inch general purpose wood screws and twelve 1½-inch general purpose wood screws. To complete this project, the materials should be purchased. They can then be cut to size and assembled.

Purchasing bill of materials:

Top - 36-inch length of 2" x 4" material

Legs (4) - 22-inch length of 2" x 4" material (totaling 88 inches in length)

End braces (2) - 11-inch length of 1" x 6" material

(totaling 22 inches in length)
Wood screws - Eight 3-inch screws and twelve 1½-

Cutting bill of materials:

One 2" x 4" board, 36 inches in length

Four 2" x 4" boards, 22 inches in length

Two 1" x 6" boards, 11 inches in length

The purchasing bill of materials can now be composed from the above information, keeping in mind the need to minimize waste and the standard sizes of lumber. A total of 124 inches of 2" x 4" lumber is needed (36 inches for the top plus 88 inches for the legs). Lumber is available starting at 8 feet in length and increasing in increments of two feet, so one 12-foot (144-inch) board will provide enough material for the project with a 20-

Eight 3-inch wood screws

Twelve 1½-inch wood screws

One 2" x 4" board, 12 feet in length

One 1" x 6" board, 8 feet in length

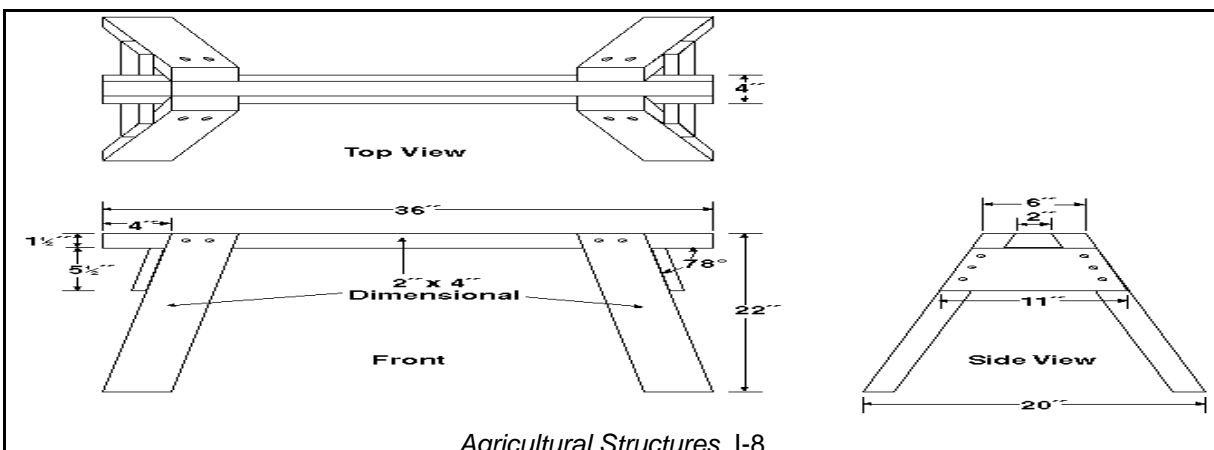

Lesson 2: Understanding a Plan of Procedure

Summary

This lesson outlines four basic steps that can be applied to agricultural structures to develop a plan of procedure. By following the steps carefully, precise material needs can be determined to successfully complete a project from beginning to end.

Credits

Taylor, Robert L. *Builders Estimating Databook*.
Blue Ridge Summit, Pa.: Tab Books, 1990.

Working with Plans

Lesson 1: Home Site Selection

Lesson 1: Home Site Selection

Whenever the construction of a new home is planned, the site must be evaluated before building. If the site is not carefully chosen, the home owner may experience problems later. The structure may not be of as good a quality as possible or may be more expensive than necessary.

Soil and Water Conditions

As a part of home site selection, the soil conditions on the property need to be considered.

The bedrock depth and soil type will affect foundation design decisions. A test should be done to determine the depth of bedrock formations or the underlying soil conditions at possible sites.

Any site with surface and subsurface water for more than half the year should be avoided if possible. A building site will be easier to work with and on if the location selected does not have subsurface water. Subsurface water makes concrete work more difficult by increasing the moisture level in the concrete. It also makes sealing the building difficult, which will lead to water in the basement or crawl space. Eventually, subsurface water leads to mold, mildew, or rot in wood buildings. If an entire plot has subsurface water, a drainage system may possibly be installed to remove the excess water.

Topography

Topography can be defined as the relative positions and elevations of the natural or man-made features of an area that determine the surface configuration of the land. For site selection purposes, this is simply defined as how the land lays. Topography will greatly impact construction if the selected site is on an uphill or downhill slope. Consideration must also be given to the topography that surrounds the selected site as this will determine how water and wind moves toward and away from the site.

Hillside construction will have higher costs because the need for retaining walls, grading, fill material, and general site preparation are greater in comparison to a flat site. Considerable amounts of soil may need to be either removed

or brought onto the site to make it useable. This process will require additional advance planning in securing a place to deposit excavated dirt or finding a source for dirt or proper fill material.

Topography is also important because of water runoff. Building a house at the bottom of a hill means that water will run down toward the house, possibly causing flooding or sub-irrigation problems. In addition, the location of other facilities can be a factor when considering runoff.

If a livestock lot is located uphill from a proposed home site, liquid waste may run downhill toward the home and contaminate water resources. A home site should generally be located on a higher elevation than livestock facilities or crop ground where many chemicals are used in order to allow the water runoff to flow away from the site.

The amount of wind that strikes the home is affected by topography. Homes built on hilltops or knolls generally receive more wind than those built on hillsides or at the base of hills. Natural growing trees or man-made windrows can provide protection from wind, but the topography may limit natural growth or make new trees hard to establish. Additional construction costs may be incurred to insulate and strengthen roofs and walls that are exposed to heavy prevailing winds.

A factor that should be considered is if the location offers the possibility of expansion. If an addition onto the building (such as extra rooms, a garage, workshops, etc.) may some day be necessary, careful consideration should be given to the initial site chosen for the building. Room needs to be left around the building, especially on those sides where additions may be built.

One of the most overlooked factors is the building perspective, or view. Building perspective is the direction a building faces in relation to the external scenery. If a scenic view is desired and offered by a certain direction, the view must be considered in laying out the building. The location of the larger windows, such as the large picture windows in the living room or kitchen of a house, is of particular importance.

Wind

Home and Farmstead Planning

In addition to affecting the choice of a location for the house, wind will affect how a house is laid out. If possible, the main entrance is commonly located on a side of the house away from prevailing winds. For example, in an area with strong north winds, the main entrance may be on the south side of a building. If the door faces the direction of the prevailing winds, rain, dust, and debris may blow into the house, and the wind may cause damage when the door is opened. Snow drifts can also accumulate around the door and may make it inaccessible.

Services and Utilities

Every new building requires certain services and utilities, and houses are no exception. Every house must have road access, a water source, and sewage facilities, as well as electrical power, telephone service, and possibly natural gas or propane for heating and cooking. The site chosen for a home should take into consideration the ease with which these utilities and services can be provided.

The distance to services and utilities should be considered because it will affect the cost of bringing them to the home. It is desirable to build as close to existing roads and utility lines as possible, especially electricity, telephone, and gas lines, to keep costs at a minimum. If the closest access is found at one corner of the property, the home may be placed closer to that corner because the cost of installing these services over a long distance can be considerable. The local electrical power, telephone service, and natural gas suppliers may be contacted to determine the cost of extending power, telephone, and gas lines to the home site.

If the location of the utilities is unknown, locator services can come to the property to determine the location of various utilities. Using a locator service may also reveal that some of the utilities already cross the property, which would probably lower the cost, especially with gas lines. By planning utility access, the builder can budget for the costs of bringing the utility to the building, especially if power poles, trenches, conduits, or other items are needed.

Many rural homes make use of propane gas for heating or cooking. Tanks should be located so as not to detract from the home's appearance,

yet they should be easily accessible for the propane supplier to refill. Propane suppliers will provide tanks, meters, and trenched-in connecting lines for an initial lease fee for their customers. Suppliers may also provide footing blocks, or the home builder can pour a level concrete pad to set the tank on. Home owners are required to provide a stubbed-up exterior line that is securely capped or connected to the heating system and/or appliances.

Drilling a well is often necessary for rural homes in order to secure a good water supply. State law requires all wells used for drinking water to be drilled to at least 80 feet to prevent groundwater runoff from directly entering the system. Knowing the average depth of drilling to reach quality water prior to selecting the site may influence selection because drilling costs are based on the number of feet drilled and the soil structure where the drilling will be done. The depth of the well can vary greatly in different areas. In Boone County, Missouri, good water sources can be reached at 80 feet, but in nearby Howard County, wells generally need to be drilled to 250 to 400 feet. In Howard County, drilling through hard rock to install a six to eight inch well casing would currently cost approximately \$900 to \$1,500, not including the cost of a submersible pump or the pipe line and trenching from the well to the home. To determine the approximate drilling depth, homeowners should contact the Missouri Department of Natural Resources, Division of Geology and Land Services, for information about water availability and location.

Several rural areas throughout the state have access to rural water districts. Water is purchased and piped from a nearby town or city's reservoir or well system. A homeowner can hook into this system for an initial fee and then purchase water based on usage on a monthly basis. Using a rural water district may be more cost efficient than drilling a well if the distance to the connection is fairly close and if the topography presents no major obstacles. Livestock and crop producers may still consider drilling a less expensive well for farm use in addition to using rural water.

Sewer service is seldom available outside city limits. If it is not, the builder will need to arrange for a private sewage disposal system to be constructed. A large area of land and

Lesson 1: Home Site Selection

suitable soil is necessary to prevent contamination of surface water and wells. Septic systems should be located away from home and building sites. Local or county sewer regulations should be consulted before building to determine if a site is acceptable. Many

Access to the site for concrete, lumber, and other material deliveries is important for construction. Consideration should be given to where the roads currently are and where they will need to be built on the property to provide access. Roads and room for turning around should be provided. Time should be taken to consider where a lawn or any other landscaping will be prior to laying out the roads. Geomat, a mesh material, is commonly placed on the ground to provide traction for vehicles if the site is wet and muddy. Bridges may need to be added to allow access for trucks and other vehicles.

Regulatory Agencies

Generally, more agencies will affect construction within city limits than in rural areas. In many communities, fire codes and local building codes that set guidelines for building need to be taken into account when planning a structure. For example, fire codes may specify the distance from other buildings necessary to provide fire trucks and other emergency equipment access to the site. Common building codes include regulations for the reinforcement of concrete structures, service access, and utility access. An inspection is often required prior to beginning the project to make sure the building will be constructed according to code. For information about the codes for a particular area, the local building inspector or county commission can be contacted.

Zoning laws may also affect construction. Many communities have zoning laws that prohibit the construction of private homes in areas that have been zoned for commercial development. The local zoning commission, building inspector, or assessor can usually identify local zoning laws that apply to the site being considered.

In a rural area, builders may only need to obtain permission for construction from a county board of commissioners. The amount of regulation will depend on the local area, however. In some places, sewer fields must be approved

counties will not allow a septic tank or sewer field to be placed within a certain distance of rivers or ponds.

prior to construction, generally by a local or county sanitation board. Zoning laws have also become much more common in many agricultural areas.

Neighbors

As more homes are built in rural areas, the issue of neighbors becomes more relevant. The location of neighboring homes can impact the selection of a building site for a home. Some landowners choose to build the home as far as possible from other neighbors to obtain greater privacy. However, if neighbors are also relatives, some home builders may select a site that is relatively close to neighboring homes. This practice may allow for more family interaction and promote a greater sense of security.

Having the Home and Business on the Same Site

A number of issues must be considered when building a home on a business site, as is commonly the case in agricultural situations. If the home is located on the site, the possible sale of the home at a later time needs to be considered. Many owners choose to sell an existing home to finance the construction of a new one. If the home is in the center of some type of business site, it may be difficult or impractical to sell. If the home is located on the edge of the property separate from the business, selling the home will be easier but will require accepting new and closer neighbors. Also, road access to the farming or business operation may have to be added, as well as connections to services and utilities.

Another reason builders should consider the possibility of locating the home in an area away from business activities is because excessive noise, traffic, or pollution may be a problem. Odors, fumes, dust, and other problems are not desirable and can be a health concern at the home site.

Home and Farmstead Planning

Having the home site near the business operation may also pose potential safety problems for the residents, especially children. Agricultural operations use numerous pieces of equipment that are dangerous. They can be even more dangerous to children, who may not realize how to protect themselves. Many Environmental concerns are very important when selecting a site for a home. Before a site is chosen, a number of environmental issues should be considered. An environmental audit (definition) examines the potential building site to determine if any environmental issues will need to be addressed prior to construction. An environmental audit can alert home builders to a number of potential hazards and what measures can be taken to eliminate any problems.

Several potential problems may exist that can be determined through an audit. One of the most significant environmental and safety problems is the existence of abandoned wells, especially on old farmstead sites. As new drilling techniques and regulations have come into use, many old rock wells have been abandoned or even used to dispose of hazardous liquids. Even modern wells have been abandoned for rural water connections. Their locations are seldom recorded, and often these well openings are hidden by natural overgrowth until they are discovered, sometimes through dangerous accidents. A thorough environmental audit can help identify any abandoned wells through a study of county records of the property and a physical evaluation of the site. Other potential problems that should be considered are the identification of underground storage tanks, old landfills, or dump sites. Underground tanks may have held substances like gasoline or diesel fuel, and landfills or dump sites could contain chemicals that are harmful to humans if they get into the drinking water.

people prefer to locate the home away from more hazardous activities to help ensure the safety of children and visitors.

Environmental Concerns

Summary

When considering the selection of a site for a home, a number of issues should be addressed, including topography, wind, services and utilities, regulatory agencies, neighbors, locating the home and a business on the same site, and environmental audits. By carefully considering each of these factors before selecting a site for construction, problems can be avoided in the future.

Credits

Kicklighter, Clois E. et al. *Architecture: Residential Drawing and Design*. Tinley Park, Ill.: Goodheart-Willcox Company, 1995.

Lindley, James A., and James H. Whitaker. *Agricultural Buildings and Structures*. Rev. ed. St. Joseph, Mich.: American Society of Agricultural Engineers, 1996.

Lesson 2: Arranging a Farmstead

A farmstead can be defined as a farm and its structures. Preparing a farmstead plan involves many variables and complexities. Developing a good plan requires considerable forethought and effort. This lesson outlines major considerations in farmstead planning and will show how to systematically address issues. Also, long-term goals must be kept in mind from the beginning to achieve the desired results. A good farmstead plan will involve research and outside help. Local University Extension offices are an excellent source of information and referrals.

Direction of Farmstead Layout

Farmstead planning often involves orienting activities in relation to one another and the farm's effect on surrounding areas. Efficiency of farm operation is a key to farmstead planning.

To be efficient, a farm will have to be laid out in a convenient fashion. Structures associated with related activities, such as feed storage facilities and feed lots, should be located near one another. In addition, the noise, dust, pollution, and insects associated with agricultural activities must be anticipated and directed away from residential areas, which can be a challenging proposition. These conditions occur to some degree in most farm enterprises, but if they are taken into account during planning, detrimental effects can generally be minimized. However, if a farm is the source of significant amounts of noise, dust, pollution, or insects, locating activities at a suitable distance from residential areas may be the only choice.

Orientation of structures according to the four directions is usually done to minimize the effects or take advantage of natural elements such as sun or a prevailing wind. Orientation of individual buildings is a function of the type of building, type of enterprise, and desired outcome of the structure's use. An example of this type of planning would be orienting a greenhouse with a large translucent wall to the south to gain extra sunlight or positioning a milking parlor with milk storage tanks receiving the least southern exposure possible to avoid sunlight, which will heat the tanks.

Topography

The actual topography of a large area would be very difficult, and perhaps impossible, to change, so a successful farmstead plan must take advantage of the resources and options to which the available topography lends itself. Drainage, the removal or flow of water from an area, and pollution are of particular concern when considering topography. Addressing these concerns in the planning stages is critical to an operation's success. For example, drainage of water from rain, snow, ice melt, or farm operations should be away from structures, with a slope of 3 to 5 percent. As water passes over the ground, it may erode soil; a slope of 3 to 5 percent will allow for drainage without promoting erosion. Water can also damage structures if allowed to drain into them, which is why a slope away from structures is advisable.

Pollution that may enter the watershed from agricultural enterprises must be managed. Exactly what constitutes a pollutant and what management practices will be required are generally governed by law and are specified in codes and regulations concerning specific enterprises and their by-products. Topography plays an essential role in pollution control in that understanding a given area's topography will provide an understanding of the direction and routes of drainage. Structures such as dams, holding ponds, or routing channels are sometimes effective in controlling the effects of pollution in a given area.

Topography is also a significant factor in regard to accessibility for machinery, water retention, and soil components. To some extent, topography explains why similar farm enterprises are located in similar geographic regions. Often, the reasonable uses of a property are limited or more adapted to a particular type of enterprise because of the topography of the area. An example would be marshy areas that may support rice production, but little else. Whatever the type of enterprise, the topography must be able to support the operation's activities profitably. A row crop operation will require relatively flat land with few stones. On the other hand, beef cattle operations may work well in a hilly, rocky area.

Wind

Home and Farmstead Planning

Wind erosion can be a significant factor in many farm enterprises, especially field crop enterprises. Historically, wind erosion has been devastating to farmsteads in susceptible areas. Preventing wind erosion may be impossible. Wind breaks are a key to success in dealing with wind erosion.

Most wind breaks are rows of trees strategically planted and spaced to interrupt a prevailing wind.

While they are helpful, establishing wind breaks is usually time consuming. Effective wind breaks need very careful planning; consulting an agricultural engineer is recommended if a large wind break is needed. Orienting a structure to act as a wind break is helpful in shielding small areas from a prevailing wind. For example, locating cattle holding areas on the side of a barn or milking parlor away from winds provides shelter for the animals.

Wind must also be considered when planning for enterprises that involve odors or airborne contaminants. Residential areas need to be protected from both of these problems. If the farmstead in question has a prevailing consistent wind, devising plans to address airborne contaminants may be easier. Such winds can be an advantage if they blow away from an area where windborne contaminants may cause problems. However, if a prevailing wind is carrying contaminants into an inappropriate area, the most effective solution is to locate the source of the odors or contaminants at a distance from other activities. Consulting with an agricultural engineer experienced in these issues may also provide aid in determining options. These problems may be controlled somewhat through the use of specifically designed ventilation systems and filters as well as regular cleaning and good waste management practices.

Heating and cooling requirements are affected by wind. Prevailing winter winds from the north are of considerable concern when evaluating heating requirements. Reducing the number of windows or their size on the north side of structures and taking advantage of wind breaks can be of help in reducing heating needs. Orienting farm structures to take advantage of wind for ventilation can help in meeting cooling requirements as well as enhancing livestock health.

Natural Resources and Environmental Impact

Natural resources are material sources of wealth that occur in a natural state, such as timber, water, or mineral deposits. Taking advantage of the natural resources an area provides is advantageous to farming operations. However, natural resources must be used in compliance with the regulations governing their use. These laws are designed to protect the environment and its inhabitants. Complying with these regulations can be complicated. The codes and regulations are constantly changing and evolving as the U.S. government becomes more and more involved in meeting concerns for public and environmental health. As a result, many agencies have been formed to monitor and ensure compliance with environmental regulations.

This focus on regulations greatly affects farmstead planning. Agricultural production has become a highly industrialized activity that involves countless chemicals and waste products, which makes agricultural operations subject to many regulations. These items all have the potential to damage the environment if misused. Generally speaking, any fuel, waste products, or chemicals used in amounts considered to be at a commercial level will be regulated. Each enterprise will have different circumstances, which will affect its regulatory requirements. Of particular concern is any contaminant that can enter and be spread in the watershed, contaminating valuable natural resources.

Type and Size of Business

Agriculture is a varied industry, and specific circumstances require individual consideration. The type and size of business affects many aspects of farmstead planning. It directly influences farm acreage needs, the number and type of structures required, the number and type of regulations affecting the operation, financing options, the source and amount of water, and waste management.

Farm acreage needs - Different enterprises require acreage suitable for their needs. Each enterprise's needs are different. A beef cattle operation may require hundreds of acres, while a greenhouse may only need half an acre. Careful consideration of future needs must take place during the first stages of planning if

Lesson 2: Arranging a Farmstead

possible. The planner must think about what the operation might be like in 20 or 40 years.

Number and type of structures - The number and type of structures on a farmstead also must be adapted to the specific operation's needs. No one structure will meet every need. When planning a farmstead, an individual must do research to find information concerning the type of structures needed for a particular operation. Trade associations dealing with a particular type of enterprise are a good place to start asking questions. University Extension services may also be an excellent resource. Contract producers in the swine or poultry industries work closely with the processors with whom they contract to develop plans for farmsteads and structures designed for efficient operation.

Number and type of regulations - Research is required to determine what regulations might affect each aspect of the farmstead being planned. A county planning and zoning office would be an excellent place to begin a search for information. County Extension offices are also a good place to start. The planner will likely be referred to other agencies that deal with more specific details concerning the farmstead's planned operations. As a rule, larger operations require more and larger structures and produce more waste. They are therefore subject to more regulations.

Financing options - Because agricultural enterprises are generally businesses requiring a profit to be successful, financing options are critical. Agricultural operations have been lost to foreclosures and bankruptcies. Structures are expensive to construct and maintain, so careful planning is required when determining structural needs. Obtaining professional advice concerning farm financing is recommended. In areas where agricultural enterprises are common, professional accountants experienced in financing should be available.

Sources and amount of water - All farm enterprises require some amount of water. Many of them can require very large amounts, such as irrigated crop enterprises or large dairy operations. Water needs should be anticipated and evaluated in the planning stage. Often, water needs are greater than first expected, so careful research is required. The types of water sources, such as rivers, creeks, ponds, wells, and municipal water, and amounts they can

deliver must be considered as well. Planning for structures should take into account convenient access to water supplies and drainage of wastes away from water sources. Laws and regulations may affect the options for water for the operation.

Waste management - Waste management must be planned according to the codes and regulations governing the enterprise. This area of farmstead planning is often a complicated one. Waste management structures such as holding tanks or lagoons are critical for the environment and must be planned carefully. The failure of these structures can lead to extensive damages for which the operator is liable. Lesson 2 of this unit contains more information about this topic.

Services and Utilities

Both the services and utilities available must be taken into account during farmstead planning. Utilities of an acceptable level and dependability must be available at a cost that will allow profitable operation of the chosen enterprise. Services that affect the particular enterprise in question must be available and consistent enough to allow profitable operation. Utilities and services include electricity, passable roads, fire protection, ambulance services, and telephone services.

Depending on the type of enterprise involved, the utilities and services needed can be extensive, and they may be critical to the success of the business. Two good examples are dairy and greenhouse enterprises. Power outages at milk times can be disastrous, as can an access road that the milk truck cannot use. Loss of heat to greenhouses during cold weather can devastate the entire inventory of plants.

Utilities and services must be considered when arranging the layout of structures. Overhead electrical lines should be located away from trees if possible, since falling limbs may break lines; underground lines tend to be more dependable. If water is supplied by a municipal source, structures must have suitable hookup access.

Planning for Neighbors

Home and Farmstead Planning

Laws and regulations, particularly zoning laws, will dictate much of what is acceptable when planning in regard to the neighborhood surrounding the farmstead. Most new agricultural enterprises will be required to locate in areas approved for these types of businesses.

The potential for zoning changes and urban encroachment in the future should also be taken into account. If such changes are a possibility, the farm's operations may not be allowed to continue, and structures may have to stand unused. Some other concerns need to be considered, such as pollution and runoff that may affect neighbors, especially when planning structures that involve or alter watershed activity.

For example, clearing timbered acreage to build a structure on a hill above a neighbor's home will create a greater amount of runoff, with the potential to damage a neighbor's home. Fences that separate properties and are used by both parties are worthy of consideration when forming a farmstead plan; agreeing on which party maintains the fencing may be important.

Regulatory Agencies

Regulatory agencies that are designed to protect the environment, its inhabitants, and natural resources have a direct effect on most farm enterprises. Compliance with regulations for such things as pollution control can be costly and involve considerable labor. Regulations may limit the size an enterprise can operate at successfully. However, they also work to ensure that the environment is safe for everyone. Two major regulatory agencies that provide guidelines and answers to questions for farmstead planning are the Environmental Protection Agency (EPA) and the Department of Natural Resources (DNR). State branches of these offices are excellent sources of information and will in most cases be an excellent place to start as well as a good source of referrals. Although this subject is large and complicated,

resources to aid in understanding these regulations are readily available from the sources mentioned in the lesson as well as many specific subgroups of these agencies. The local planning and zoning office may also provide answers to many questions, and the staff may have current recommendations for sources of information on anything that is out of their scope of expertise.

Summary

When planning a farmstead, developing a good plan can be accomplished by listing the desired facts concerning the proposed enterprise. The size and type of business and its specific needs must be defined. Factors such as the direction of layout, topography, wind, natural resources, utilities and services, and location of neighbors are another consideration. Compliance with regulatory agencies may have a great effect on farmstead planning.

Credits

Animal Waste Regulations for Livestock Producers in Missouri (WQ200). University Extension Agricultural Publications, 1993.

Environmental Protection Agency. "Office of Enforcement and Compliance Assurance." <http://es.epa.gov/oeca/> (31 August 1998).

Lindley, James A., and James H. Whitaker. *Agricultural Buildings and Structures*. Rev. ed. St. Joseph, Mich.: American Society of Agricultural Engineers, 1996.

Missouri Department of Natural Resources. "Soil and Water Conservation Service Program." <http://www.dnr.state.mo.us/deq/swcp/faqs/wcp.htm> (17 August 1998).

Lesson 3: Livestock Manure Management Systems

Lesson 3: Livestock Manure Management Systems

Everyone involved in farmstead planning for livestock operations needs a basic knowledge of manure management. Acceptable management practices are dependent on factors such as the size and type of operation and soil conditions. Research into the requirements for the use of manure is therefore imperative for each livestock operation.

Principles of a Manure Management System

Animal manure contains materials, including nitrogen and, to a lesser degree, phosphorus, that can be harmful when concentrated in large quantities. Effective manure management is required for any operation to manage these substances, but with the development of larger operations, particularly in the beef, dairy, swine, and poultry industries, the complications of dealing with large amounts of manure have increased. The potential for manure to enter surface and ground water is, in most circumstances, the greatest threat, and the main goal of manure management systems is to prevent this type of pollution.

A manure management system generally consists of some sort of manure storage and handling. For livestock operations in which the animals are kept on a well-maintained pasture, manure storage and handling is generally not an issue, because the livestock manure is spread throughout the pasture. However, when animals are kept on lots or in some sort of confinement system, the manure that they produce must be handled efficiently to avoid pollution, maintain sanitation, and make use of the nutrients in the manure for fertilizer. Producers have a number of options for managing manure; the methods chosen will depend on the conditions of the livestock operation. Common storage options include pits underneath buildings with slotted floors, storage tanks, and lagoons. Common methods for applying the manure to fields as fertilizer include pumping it through irrigation systems and applying it to the land using some type of mechanical spreader.

The exact type of manure disposal system needed will be dictated by many factors, such as the size and type of enterprise, its location, costs, local zoning regulations, the volume, odor considerations, proximity of neighbors, and use of manure as fertilizer for crops. While the type of system or practices that will be required to operate successfully will vary, most systems are strictly regulated to protect the environment.

Regulatory Agencies Involved in Manure Management

The number of agencies and specific divisions of agencies that are involved in livestock manure management is growing and evolving as the issue of handling manure effectively becomes more critical. Help can be obtained from the following agencies at the federal, state, and local levels; referrals from these agencies will lead to answers for most questions. Most of these agencies also make information available on the World Wide Web.

Department of Natural Resources (DNR) - The Missouri Department of Natural Resources is a state agency that monitors natural settings, evaluating soil and water quality and the effect of pollution. They enforce regulations concerning pollution. This department may provide information about designing manure management systems.

Environmental Protection Agency (EPA) - The EPA is a federal agency responsible for the enforcement of federal environmental policies and laws. The agency provides information on the laws and rules governing the use of manure. This information would be especially useful when designing the system.

Planning a Manure Management System

Farmstead planners should carefully research the different types of manure management systems available and obtain professional help as needed. This aspect of the farm plan should not be taken lightly; whatever system is chosen, it must work properly for the enterprise to be successful. The regulatory agencies listed above will be of some assistance in choosing a manure management system. The following sources of information may be able to supply specific designs and referrals to other sources. These sources can be located through phone

Home and Farmstead Planning

directories, library reference services, or Web searches.

- Natural Resource Conservation Service (NRCS) offices
- Associations for a particular species of livestock (such as the National Pork Producers Council and National Cattlemen's Beef Association)
- Private agricultural engineering firms
- For producers with contracts with large corporations, engineers who assist with design that are hired by the corporation

Summary

The main goal of manure handling systems is to prevent the pollution of surface and ground water. Depending on the type of livestock enterprise, manure management can be very involved. Planning for an appropriate system may require

- University Extension offices

research involving government agencies, livestock associations, and other sources of information.

Credits

Animal Waste Regulations for Livestock Producers in Missouri (WQ200). University Extension Agricultural Publications, 1993.

Ensminger, M. E. *The Stockman's Handbook*. 7th ed. Danville, Ill.: Interstate Publishers, 1992.

Steele, Kenneth. *Animal Waste and Land Water Interface*. Boca Raton: Lewis Publishers, 1995.

Lesson 1: Construction Safety

This unit presents an exploration of building construction. Bureau of Labor statistics for 1997 show that the construction and agriculture (including forestry and fishing) industry divisions both have high fatality rates relative to the level of employment in those industries. Because these industries have such high rates of injury and illness, the first lesson of this unit focuses on safety. Being aware of and following good safety practices is absolutely imperative to protect everyone involved in the construction of a structure. It is important to stay alert, pay attention, and think ahead to avoid injury.

A few general considerations may help prevent or reduce the seriousness of injuries. Suitable protective equipment and clothing should be used as necessary. Long pants, long sleeves, and thick-soled shoes or work boots are highly recommended. For some jobs, a hard hat, work gloves, eye protection such as goggles or safety glasses, and hearing protection like ear plugs may also be required. Workers should try to avoid hazardous jobs while alone or isolated from others in case an injury occurs that requires assistance. Keeping a first aid kit at the site may also help in dealing with any injuries that do occur.

Heights and Safety

Working with heights is often unavoidable in construction. Falls from heights contribute significantly to the number of injuries and fatalities that occur in construction. While heights do present some special safety concerns, the risks can be minimized by observing the following safety tips.

- Ladders or any other equipment, such as scaffolds or lifts, must be well maintained and in good working order. Never use faulty equipment.
- The base of a ladder or the legs of a scaffold must be properly seated. They must be evenly set on a solid, non-slippery surface.
- Use any applicable safety equipment, such as safety belts and boots with non-skid soles.

Structural elements are all the materials that go into a construction project. They will vary with

Building construction	Specialization in:
Remodeling and renovation	Foundation work
Estimator	Framing
Bricklayer	Drywalling
Heavy equipment operator	Insulating
Terrazzo builder	Roofing
Building supply retailer	Siding

- Use extra caution when carrying materials. Keep loads small enough to be manageable.
- Be aware that roofs can be slick, especially early in the mornings when dew may be present. Move slowly and carefully.
- Do not attempt to work at heights if experiencing any dizziness or disorientation.

Safety with Construction Equipment and Tools

Construction projects may involve the use of a wide array of equipment and tools. Some of them, such as a hammer, are very simple to use, while others, such as propane torches, require more knowledge to operate correctly. However, most equipment and tools can cause injuries if they are handled carelessly. To use construction equipment and tools effectively and efficiently, remember the following tips.

- Keep tools well maintained and in proper working order.
- Use tools for their intended purpose. Most tools are designed for specific purposes, and their use for other jobs is frequently unsatisfactory or dangerous.
- Follow the manufacturer's instructions for the use of equipment and tools. Also, take heed of any safety recommendations.
- Fatigue will dull the senses and can contribute to carelessness, which can be hazardous when working with equipment and tools. Take breaks as needed. Construction work requires your full attention at all times.

Safety and Structural Elements

each project. Some examples would be lumber, steel, concrete, and plumbing and electrical

Building Construction

supplies. To handle these materials safely, remember the following guidelines.

- Unloading materials at a work site can present a variety of hazards. Materials may be large and heavy. Care should be taken when loading and unloading. Avoid standing where materials (or the equipment handling them) could be a hazard in the event of a mishap. Always try to find a position that would be safe from an unexpected spill--at the end of the material if it is stacked very high or, with concrete being delivered, facing the truck while it unloads.
- Care and good technique are necessary when lifting construction materials. They should be moved in some other way if possible, such as pushing, rolling, or sliding. If materials must be lifted, the best way to do so is to bend at the knees, keeping the back straight, and lift the object by straightening the legs. The process should be reversed when setting materials down. To turn, the feet should be moved to a new position; twisting at the waist should be avoided to prevent back injuries.
- Some materials, such as concrete, may be caustic and should be handled wearing protective clothing and boots.
- Electrical hook-ups are often necessary at construction sites. They should only be assembled by someone who is very knowledgeable and qualified to establish

such service. Sufficient grounding and devices that provide protection from current (such as circuit breakers) must be in place.

- Materials and waste materials should be kept organized and out of the way while working. Leaving materials in an area of activity creates a situation where workers can trip.

Summary

While following the tips on working with heights, equipment and tools, and structural elements given in this lesson will improve safety at a construction work site, the most important step in preventing injury may be paying close attention to what is happening. An awareness of what is going on will allow a worker to avoid hazards and thus reduce injuries on the site.

Credits

National Institute for Occupational Safety and Health (NIOSH). "The National Ag Safety Database (NASD)." <http://www.cdc.gov/niosh/nasd/nasdhome.html> (5 Oct. 1998).

Bureau of Labor Statistics. "National Census of Fatal Occupational Injuries, 1997." <http://stats.bls.gov/special.requests/ocwc/oshwc/foi/cfnr0004.txt> (13 Oct. 1998).

Lesson 2: Building Designs

Agricultural structures use many different types of styles and designs because of the vast diversity of agricultural enterprises. This lesson describes some common building designs and factors that should be considered when designing and constructing agricultural structures.

Designs for Agricultural Structures

Although any conceivable design or combination of designs may be used for agricultural structures, certain basic shapes and roof styles are most commonly used. Structures are generally square, rectangular, round, or oval in shape; they may also be some combination of these shapes. Roof styles also are a significant factor in design; many structures are commonly referred to by the roof style used. Seven roof styles--gable, hip, mansard, gambrel, shed, Quonset, and Gothic/arched--meet most agricultural needs. A gable roof has two sloping sides that meet at the peak of the building, while a hip roof slopes on all four sides from the peak.

A mansard roof is similar to a hip roof in that it slopes on all four sides, but the upper part of the roof is flat. In the gambrel roof style, the sides slope slightly from the ridge to about halfway down the roof and then slope more steeply. A shed roof is sloping, with no ridge. A Quonset building is basically a half circle, with a rounded roof and walls. A Gothic or arched roof has two continuous curves that come to a peak to form the roof. Figure 2.1 shows these different styles.

Methods of construction vary with the types of materials selected for the structure. Several common methods of construction are used when building agricultural structures. Agricultural structures may also make use of aspects of all four of these basic methods of construction.

Wood frame - Wood frame construction involves the use of weight-bearing upright wooden members for the walls of a building. An example of this type of construction is a shed with stud walls.

Pole - In pole buildings, often called post frame buildings, large wooden timbers are placed in the ground and serve as the weight-bearing skeleton

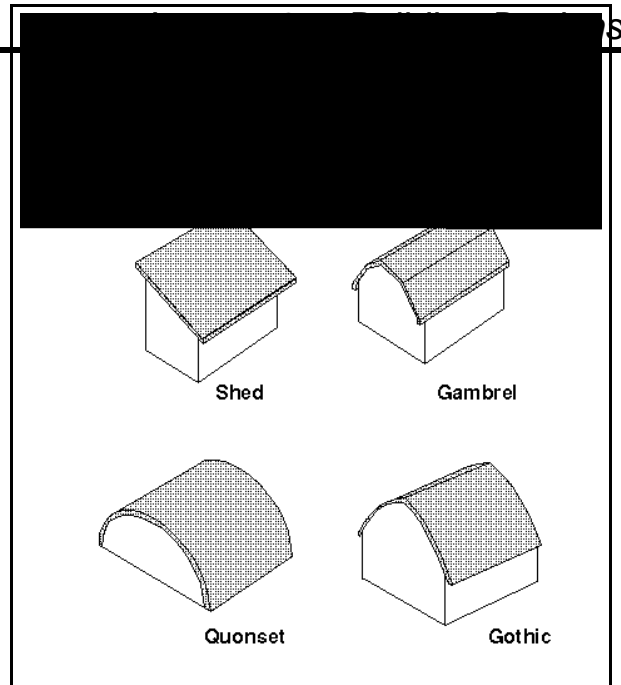

of the building. This type of design is often used for hay barns and shelters for farm machinery. **Metal** - Metal construction refers to any structure where metal is used as a primary component of the building. Because of its strength and stability, metal is sometimes used in place of wood in pole-type construction. Structures are built by welding and bolting the materials together. This type of construction is often used for machine storage sheds.

Masonry - In masonry construction, concrete or masonry blocks are the primary building material.

Buildings are constructed by pouring concrete in forms or laying blocks. The use of masonry is very common for some types of agricultural structures, such as manure handling, because it produces a durable surface that can be cleaned and disinfected easily.

Advantages and Disadvantages of Different Designs

The advantages or disadvantages of each type of structure must be evaluated while keeping in mind its intended uses, the builder's options, and site restrictions. One type of structure cannot successfully meet the needs of every possible situation. To evaluate the suitability of a structure for a project, the following questions should be considered.

Building Construction

- Will the structure serve its intended purpose? Is it efficient?
- Are the construction and operating costs reasonable? Will using a particular design or material save money?
- Can the building be heated or cooled if required?
- Are the building materials durable enough to last for the life of the structure?
- Can the building be partitioned off or expanded if necessary?

Wood frame structures are often more economical than the other types. They are usually relatively easy to partition or expand. However, wood frame buildings will likely require more maintenance and may not be durable under conditions of abusive use. They also pose an inherent fire hazard because of the use of wood in their construction.

Pole buildings can be constructed rapidly and economically. With good maintenance and repair, the buildings can have a long life span. Partitioning or expansion of the existing structure is usually easily accomplished. However, they may provide inferior weather protection, because they often do not have solid sides. They generally cannot be heated or cooled without modifications being made to the structure.

Metal buildings often are serviceable for a long time; they are also fire resistant. Disadvantages of metal structures are that they may be expensive and require special equipment and considerable skill to build. They also may be short-lived around manure.

Since masonry can be cleaned and disinfected easily, as discussed above, it is often the best choice for structures that require frequent cleaning with water. Masonry is also fire resistant. The life span of masonry or concrete structures is generally very long, and they require minimal maintenance. Building with masonry may be more costly, however. The use of concrete may also require extensive excavation, depending on the topography. While masonry structures may be expanded or partitioned, tearing down masonry for expansion is a labor intensive process.

Factors to Consider For Design or Construction

A structure's intended uses must be specifically identified before the style of the design or the materials used are determined. The activities that will take place in a building may determine the best type of design. For example, a pole building will generally not be appropriate for swine nurseries.

A second factor to consider is whether the cost of construction is reasonable enough to allow successful operation or use. The building's use must justify its construction cost. An example would be to borrow money to erect a hay storage facility at a cost of \$100,000 and only produce enough hay to average \$5,000 per year in returns, which would likely not pay the interest on the loan or produce any profit.

The builder must determine whether the proposed structure is appropriate for local environmental conditions. Different designs and building materials affect a building's ability to function in its environment. Before making any decisions about design and the materials used, determining the amount of weather protection needed is important. The steepness of the roof will affect the structure's ability to deflect rain, snow, or ice. The type of wall construction and the materials used will determine how much weather protection is provided by the walls. Foundation designs vary from bare earth to raised floors of metal, concrete, or wood products that meet the requirements of the environment and the structure's intended use. The tremendous diversity of building materials, designs, and environmental conditions makes it impossible to give specific recommendations. However, tables and charts that detail specifics for weather and load, which is the weight carried by a part of a structure, recommendations are available from sources such as University Extension services, libraries, and manufacturers of building materials.

Since some structures may be unacceptable according to the regulations for a particular area, codes and regulations for construction must be consulted when choosing a design for a structure.

A county planning and zoning office can supply specific information about required wiring, plumbing, structural specifications, and permits. They may also suggest additional sources of information.

Finally, the efficient use of materials must be considered. The efficient use of materials is often a compromise because using them efficiently to provide the most space does not always yield the most functional design. Even though a square, rectangle, and circle have the same perimeter, they do not contain the same amount of interior space. Rectangular buildings are the most inefficient use of materials; however, they are frequently the most functional in use because the flow of activities typically follows a horizontal line. Square designs are more efficient and are suitable for many applications, although they are not as popular in the construction industry. Circles are very efficient in the use of materials but are usually not efficient in use or ease of construction.

Summary

When choosing a design for an agricultural structure, the intended use of the structure is perhaps the most significant factor, although other factors that may affect the design and its advantages and disadvantages must also be considered. Information is readily available to provide help in identifying options. Anyone considering constructing a large structure should seek appropriate help, which is often very inexpensive or free from government sources. Professionally prepared plans generally are designed to take many factors into account and may be an excellent choice for use in constructing a structure.

Credits

Burch, Monte. *How to Build Small Barns and Outbuildings*. Pownal, Vt.: Garden Way Publishing, 1992.

Huth, Mark W. *Construction Technology*. Albany, N.Y.: Delmar Publishers, 1989.

Lindley, James A., and James H. Whitaker. *Agricultural Buildings and Structures*. Rev. ed. St. Joseph, Mich.: American Society of Agricultural Engineers, 1996.

Lesson 3: Building Materials

Many options are available for materials for use in construction, and structures may contain a variety of materials. Evaluating factors such as the project's purpose and the availability and cost of materials will be necessary to select the appropriate materials.

Different Types of Building Materials

Agricultural structures are constructed from many types of materials. Among the materials used are wood, metal, concrete, clay bricks and tiles, vinyls, plastics, glass, and fiberglass.

Wood products come in a variety of forms, including boards and plywood. They have many uses, including structural members for building the frames of structures, siding, and floors. Because wood is so common, it is the focus of this unit.

Metal products, such as steel and aluminum, are widely used in agricultural projects, often for structural members, roofing, or siding. Specific uses include support beams, roofing, sealing for the edge of a roof, trim on the corners of buildings, and many others. Metal materials generally are sold to an exact size, since cutting is more difficult than it is with lumber. Metal is also more difficult to patch or repair on a building.

Concrete products are most often found in medium-sized and large structures, usually in the foundation and often in various other parts of the structure. Concrete may also be used for sidewalks, driveways, and other paved areas. Concrete products used in construction include cinder blocks and mixed concrete. Concrete products are generally sold to meet exact specifications.

Clay bricks and tiles are available but are generally used in small quantities for agricultural structures. Bricks are sometimes used to build houses. They are generally used for decorative purposes. Other common uses of clay bricks or tiles would be for a fireplace or for walkways. Clay bricks and tiles can be purchased in many

Other possible classifications of lumber are green or kiln dried. Green lumber is lumber

different shapes and colors. They are difficult to cut or repair.

Vinyls, plastics, glass, and fiberglass have more specialized uses. Vinyl is commonly used for siding on houses. Plastics are used for skylights to allow sun into a building, as well as siding for greenhouses. Glass is used for windows, and fiberglass is used for skylights, greenhouse covers, and for livestock equipment like water tubs.

Grades and Types of Dimension Lumber

Dimension lumber refers to wooden building material sawn in lengths, usually starting at eight feet and increasing in increments of two feet. It is uniform in thickness and width. Dimension lumber makes up the framework of wood-frame structures.

As dimension lumber is processed, it decreases in size. Freshly cut lumber will shrink considerably as it dries, up to 1/16 of an inch across its shortest dimension. Surfacing and milling of the lumber, which is standard in the industry, will also claim some of the material. The measurements of the lumber before any of this processing are the nominal dimensions. Afterwards, the material is referred to as dressed.

This loss of material usually amounts to 1/4 of an inch off each side of the width and height. Thus, an eight-foot 2" X 4" is actually 8 feet long, 1½ inches high, and 3½ inches wide.

Dimension lumber is measured in board feet. A board foot is equal to 144 square inches. This measurement can be calculated by multiplying a board's nominal length (in inches), width, and height and dividing this number by 144. An eight-foot 2" x 4" is 5.33 board feet (2 in. x 4 in. x 96 in. = 768 in³.; 768 in³. ÷ 144 in³. = 5.33 board feet.)

Materials used for dimension lumber are classified as softwood or hardwood. This designation is a source of confusion in that it does not refer to the actual hardness of the wood but to the type of tree. Softwood refers to lumber from evergreen trees, such as pine or spruce trees. Hardwood is lumber from deciduous trees, or trees that lose their leaves, like oaks.

with a high moisture content. This type of lumber is sometimes used in agricultural

Building Construction

structures to save on material costs. However, it is prone to warping and twisting as it dries, which makes it undesirable for most projects. With controlled drying, much of this distortion can be avoided, and the material is much more stable. Wood is most commonly dried in a kiln, a sort of oven in which the lumber is heated, often to over 200 degrees Fahrenheit, to reduce moisture to a desired point. For example, wood used for framing is dried to about a 15 percent moisture content. Electronic moisture meters are used to determine the exact moisture content of the dried lumber.

Lumber is sometimes chemically treated for preservation. Treated lumber is more resistant to moisture and will last longer in wet climates. Generally, treated lumber will last at least twice as long as untreated lumber. Chemicals can make wood very rot resistant but require care when used, because they may be toxic. Manufacturer's recommendations should be followed carefully.

After lumber is sawn and dried to an acceptable level, it is assigned a structural grade. In the United States, the American Lumber Standards Committee sets certain standards for grading lumber. Their guidelines are generally applied, and often expanded or detailed, by regional associations such as the Western Wood Products Association or Southern Forest Products Association. These associations may set grading guidelines for the types of lumber produced in their areas.

The number of grades available is variable. Depending on the number and severity of defects, lumber is generally graded 1, 2, or 3 (1 being the highest number grade), possibly with an additional premium or select grade. Each piece of lumber graded is evaluated for the following defects.

- Knots from embedded branches or limbs
- Splits or checks, which are separations of the wood fibers along the grain or across the annular growth rings
- Shakes, or separations between the annular growth rings

- Pitch pockets, which are cavities that have or had pitch in them
- Honeycombing, or separation of the wood fibers inside of a tree
- Wane, which is bark or the absence of wood along the edge of a board
- Blue stain, discoloration caused by a mold-like fungus
- Decay caused by fungi that rots the wood
- Holes from any source
- Warp, usually resulting in bows, cups, crooks, or twists in the lumber

Sometimes other terminology is used to refer to different grades of lumber. For example, "economy" generally is equivalent to grade three.

Some areas may have further designations involving letters or terms such as (S) or Select, (B) or Better, (C) or Common, Choice, or Supreme. These letters may or may not correspond to a number system. If the grade of lumber is unclear, explanations can be obtained from the retailer handling the material.

In addition to a structural grade, dimensional lumber that has been chemically treated is labeled as treated lumber. Treated dimensional lumber for outside use has a tag attached to each piece of material with information about the chemicals used.

One thing to keep in mind when selecting graded lumber is its use. For agricultural structures, near perfect cosmetic appearance usually is not necessary. A considerable amount of money can be saved by selecting suitable material of a lower grade. When in doubt, the structural integrity of a specific grade of lumber can be confirmed by a reputable retailer.

Grades and Types of Sheathing Material

Sheathing materials are generally wood or wood product panels manufactured in one of several ways. The panels are most commonly four feet by eight feet in size, with a thickness of $\frac{1}{4}$ to $1\frac{7}{16}$ inches. The measurements of sheathing material are actual and correct.

disadvantages related to strength, cost, and weather resistance. Plywood grading systems vary somewhat depending on the type of material. Softwood plywood grades are assigned by associations such as the APA to sheathing materials manufactured to meet their specifications. The material is rated as to its suitability for interior or exterior use; generally, a rating of 1 indicates that the plywood is for exterior use, while a rating of 2 is for interior use.

Plywood with a rating of "Exposure 1" can withstand moisture but should be used indoors, while "Exposure 2" indicates plywood that should only be used indoors. The quality of the veneer used on the face and back is rated with a letter system shown in Figure 3.1.

A plywood grade stamp from the APA, which supplies a variety of information, appears in Figure 3.2. A span rating may be shown as two numbers separated by a slash. The first number is the maximum span in inches between supporting boards that should be used with this material for roof decking; the second number is the recommended span for floor decking. Other information that appears in the stamp includes the panel grade, exposure durability, and thickness.

The Hardwood Plywood Institute also has a number system used for grading. A rating of 1 or 2 is given to material with a good face and back with careful grain matching. A rating of 3 is assigned to plywood that is structurally sound but has obvious defects and patching. Softwood or hardwood plywood may also be designated G1S, meaning "good one side," or G2S for "good two sides."

Nonveneered panels are manufactured by many manufacturers and from a variety of materials. This industry is very innovative, and new techniques and forms are being developed regularly. Information on grades for these sheathing materials can be obtained from the manufacturer or retailer. They may use a system of grading very similar to that for plywood, but if in doubt, ask.

Summary

A variety of materials are used in structures, but the majority of agricultural structures contain some wood products. Wood products come in a wide variety of dimensions and grades. The

The following types of sheathing material are the most common. Plywood is made of thin sheets of wood laminated to a desired thickness. Composite plywood has a wood veneer cover laminated to some form of wood core. Nonveneered panels, such as oriented strand board (OSB), particle board, and wafer board, are all made from wood flakes, chips, or fibers that are combined with suitable resins and glues and shaped into panels. These nonveneered products are not, however, interchangeable with one another; each has advantages or

Building Construction

actual grades assigned to wood may be indicated by numbers, letters, or names. The system of grading can be confusing: asking the retailer for explanations may be the easiest way to determine the grade suitable for a project.

Credits

Huth, Mark W. *Construction Technology*. 2nd ed. Albany, N.Y.: Delmar Publishers, Inc., 1989.

Lindley, James A., and James H. Whitaker. *Agricultural Buildings and Structures*. Rev. ed. St. Joseph, Mich.: American Society of Agricultural Engineers, 1996.

<p>APA THE ENGINEERED WOOD ASSOCIATION</p> <p>1 — RATED STURD-I-FLOOR 2 — 24 OC 28/32 INCH 3 — T&G NET WIDTH 47 1/2 4 — EXPOSURE 1 5 — PS 1-9S UNIDIFLU FVV-MT TOP - 10N</p>	<p>APA THE ENGINEERED WOOD ASSOCIATION</p> <p>1 — RATED SHEATHING 2 — 48/24 28/32 INCH 4 — EXPOSURE 1 5 — 000 PS 1-9C SHEATHING RP - 108 HUD-UM-20 C</p> <p>CONSTRUCTION SHEATHING</p> <p>13 — 2R48/2F24 17.5 mm CSF 0325</p> <p>15 — ↑ STRENGTH AXIS ↓ THIS DIRECTION</p>	<p>APA THE ENGINEERED WOOD ASSOCIATION</p> <p>1 — RATED S 303 - 18 2 — 16 OC 4 — EXTER 5 — PS 1-9S P FH - UN</p>
---	---	---



- 1 Panel grade
- 2 Span Rating
- 3 Tongue-and-groove
- 4 Exposure durability classification
- 5 Product Standard
- 6 Thickness
- 7 Mill number
- 8 APA's performance rated panel standard
- 9 Siding face grade
- 10 Species group number
- 11 HUD/FHA recognition
- 12 Panel grade, Canadian standard
- 13 Panel manufacturing end-use Canadian
- 14 Canadian rated panel
- 15 Panel face indicator

Lesson 4: Fasteners and Fastening Systems

Lesson 4: Fasteners and Fastening Systems

Many forms of materials are used in construction.

They require a variety of fasteners and fastening systems. This lesson introduces some common fasteners and systems and gives some examples of where each could be used.

Groups and Uses of Fasteners

Fasteners can roughly be grouped into four categories: nails, screws, adhesives, and anchors. Nails are the most common and are generally used for attaching wood pieces together. Screws are also used for attaching wood pieces but may be used to attach metals as well. Adhesives are commonly used in agricultural construction and can bond many types of materials. For example, many trusses and roof support beams are glued together, dramatically increasing the strength of the roof, sometimes as much as 60 percent. Construction anchors are a large assortment of devices used to attach walls to foundations. Framing anchors are used to attach framing members together.

Selecting Nails

Duplex-head nails serve special purposes. Once driven into the wood, they still have a head extending above the surface, which allows them to be removed easily with the claws of a hammer.

Duplex-head nails are commonly used when nailing together concrete forms, so they can be taken apart and removed more easily. The extra head also provides a good place to tie strings for marking.

Roofing nails are used for nailing shingles in place. They have very wide, flat heads to hold shingles down. Often these nails are made of rust-resistant material, such as aluminum.

Ring-shank nails have small circles or rings around the shank. These rings make the nail hold tighter; they are also more difficult to remove. The heads of ring-shank nails are often cupped to increase their holding ability.

The most commonly used fasteners in building construction are nails. Factors that affect the selection of nails for construction are the uses of the nails, the nail length required, and exposure to weathering.

Nails come in many different styles, as shown in Figure 4.1. For example, common nails are the most commonly used type of nail, as their name implies. They are general purpose nails used anywhere a special purpose nail is not needed.

Box nails have a thinner head and shank, or body, than common nails. Being thinner makes them less likely to split the wood. The thinner heads are also easier to cover with paint. Box nails were originally used to make small boxes to ship food and other items. Now they are often used in finish cabinet work to avoid splitting. Box nails are often chemically coated to resist rusting, which can discolor paint or wood.

Finish nails have very small heads and smaller shanks than common nails. The small heads make them less noticeable, so they are useful for finishing. The nail may be countersunk, with the head of the nail set below the surface of the wood; the head is then concealed with wood putty, leaving a very nice finish for exposed, decorative wood. However, because the head is so small, the nails have less holding ability.

Ring-shank nails are used for applications where the nail will never be removed and the material needs to be held tightly. For example, ring-shank nails are often used for nailing the treads on a set of stairs. Using ring-shank nails will decrease the loosening of the boards later and help keep the steps from becoming shaky.

Screw-shank nails come in a variety of materials, like steel, copper, and aluminum, for different applications. These nails have a twisted shaft, which causes the nail to turn as it is driven into the material. Because of the twisting, the nail is difficult to remove. Screw-shank nails are used where good holding ability is needed, such as on decks. Some of these nails are very heavy duty and can be driven into concrete.

Staples are U-shaped fastening devices; its ends are driven into a surface to hold material in place.

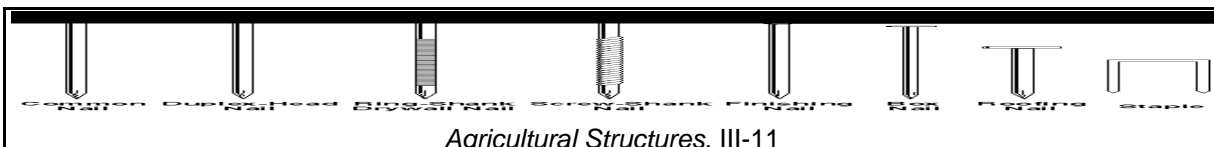

Building Construction

They are commonly listed and sold with nails. Staples are frequently used for attaching wire but are also very commonly used to attach plastics or vinyl.

Other specialized nails have a variety of uses. Some special nails attach metal roofing. These nails have a rubber washer system next to the head to help seal out moisture. Cement-coated nails are coated with an adhesive to increase their holding ability. Other specialized nails are those for use with power or air nailers. These tools drive nails with air, electric current, or gun powder. The nails used in nailers are sold in strips or coils, with the nails attached to each other to make loading the gun easier. The nails are separated as the gun drives the nail into the material. A complete array of nail and staple sizes for nearly any application are available for use with these tools.

The many uses of nails require that they come in a variety of sizes. Figure 4.2 illustrates the most common sizes, although nails come in other sizes as well, such as spikes of eight or more inches in length. Nail lengths are designated by the term "penny" and the letter "d," which was an abbreviation for penny in England.

Penny comes from the early days of nail making and indicated that 100 nails of that length could be purchased for that number of pennies. This measurement was adopted world-wide as a standard for nails. Penny does not correspond to the shank diameter; a 6d common nail, 6d finish nail, and 6d box nail would all be two inches in length but have different diameters. The diameter varies by the manufacturer and material. Typically, the nail length selected for an application should be long enough to pass entirely through one board and at least half the thickness of the board to which it will be attached.

Another factor that affects the selection of nails is their exposure to weathering. If the nails will be exposed, the builder should choose nails that will resist corrosion or staining, such as zinc or aluminum nails.

Screws

Screws are used frequently in building construction because they have a higher holding capacity than nails. As shown in Figure 4.3, several styles of screw heads are used. Round or oval heads are strong in design, but the head

remains above the surface. Flat head screws are flush with the surface and are easier to hide with paint. With pan head screws, a small head remains above the surface after insertion. Pan head screws are commonly used when the head of the screw will also be decorative, as for some cabinets.

Screws most commonly come with one of two types of slots in their head, straight-slot or Phillips (Figure 4.4). Either is available for most common screws, and both work well. Often screws with Phillips heads are more popular because they lend themselves to being driven using electric screwdrivers or drills with Phillips head bits. Other styles of slots are available, such as square, Allen, or star configurations, but they are usually designed to work with a specific tool.

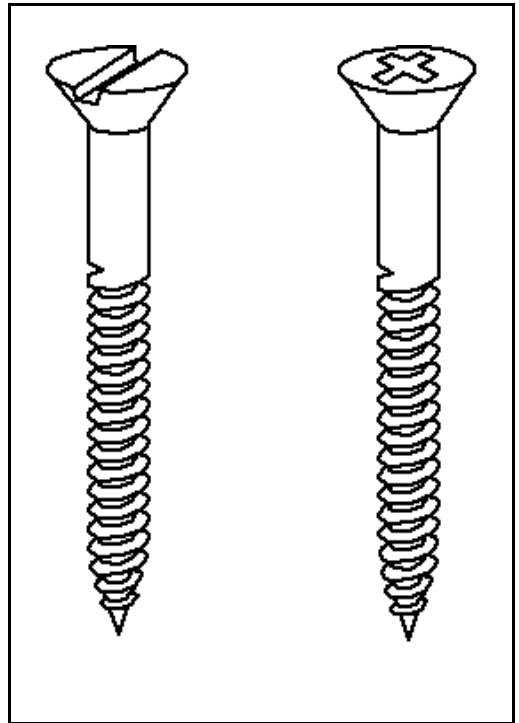
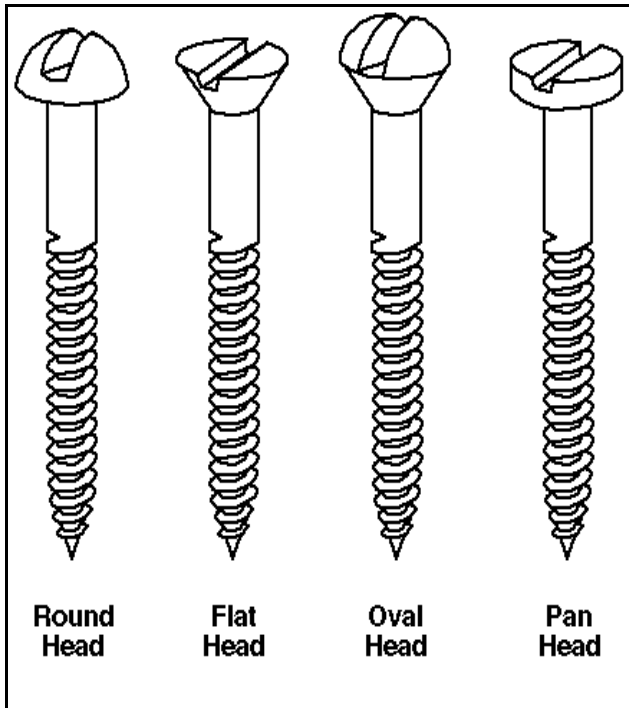
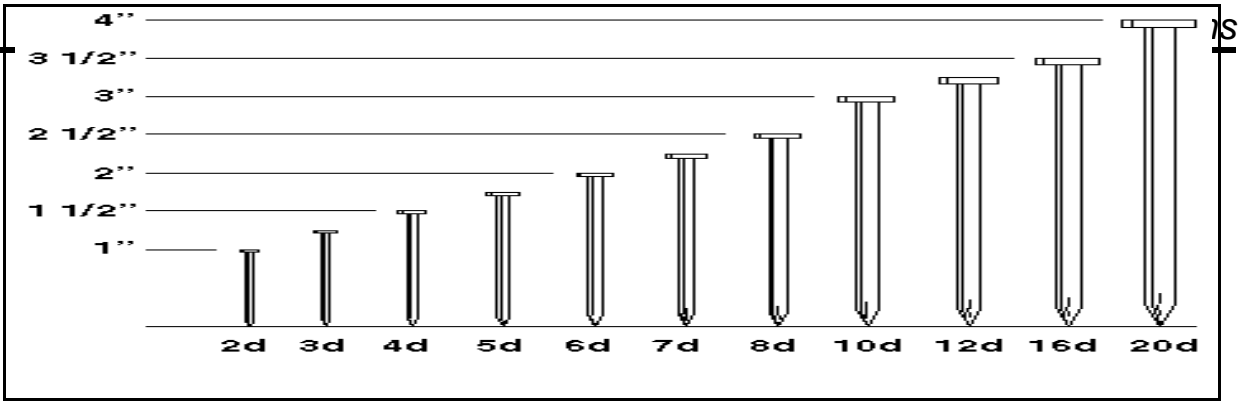

Building Construction

Wood screws are used to attach wood. They are often used in combination with adhesives, which can produce a bond much stronger than the screw itself. Wood screws may be made of several materials: brass, which is rust resistant for outside use; steel, which is stronger and less expensive than brass; or aluminum. Galvanized screws are also available for outdoor applications. Screws are sold in various lengths, usually $\frac{1}{4}$ inch to 4 inches, and by gauge, which indicates the screw's diameter. The larger the gauge, the larger the diameter; common gauges range from zero to eighteen.

Self-tapping metal screws are used with sheet metal or metal siding in building construction. These screws do not require a guide hole and will enter into the material more easily than other screws. They are usually mechanically placed and have Phillips-type heads or some type of star configuration. They are similar in appearance to wood screws and vary according to manufacturer or designated use.

Drywall screws are used to secure drywall to walls and ceilings. They have a flat head that countersinks into the surface of the drywall. They may be placed using a screw gun or an electric drill with a special drywall bit attachment.

Nails may also be used with drywall, but screws provide better holding power.

Adhesives

Adhesives are commonly used in building construction and are gaining in popularity. Their uses are increasing due to improvements in manufacturing in recent years. Two important terms need to be defined concerning adhesives. Adhesion refers to the ability of materials to stick to each other, while cohesion refers to the attraction between the molecules of a material, like the particles of wood. An adhesive with good adhesion but poor cohesion will stick to a material and then be easily pulled off.

Wood glues are used for joining woods. In the past, wood glues were made from animal products. These glues have now largely been replaced by glues based on some form of plastic.

Polyvinyl, or white wood glue, is very good for most interior or furniture woodwork. Urea formaldehyde, which is a plastic resin glue, is strong, water resistant, and adheres well to wood.

It can be used to make repairs in wood splits or to reinforce joints in a defective truss. Waterproof resorcinol resins are used on wood where water exposure is likely.

Epoxies are modern and extremely strong bonding materials. They are now being used in the assembly of automobiles, for bridge repair, and on structural steel joints. Epoxies are commonly used on fiberglass and plastics. If an exceptionally strong bond is required, consult a retailer about an epoxy product.

Mastics use cohesion to attach materials with large surface areas, such as floor coverings. They usually have a synthetic rubber base. Most mastics are water resistant. Contact cements, which are a type of mastic, are commonly used to attach laminates to counter tops or for vinyl floor coverings.

Adhesive applications or alternatives exist for nearly any fastening situation. A combination of adhesives and other fasteners is also very common and can create excellent bonds. Often cost and time are the limiting factors when deciding if adhesives are the best option.

Adhesives should always be used with caution. Many of them are highly toxic or produce toxic fumes, may be absorbed through the skin, and can be very flammable. Read and follow all manufacturer's recommendations when using these products.

Construction Anchors

Construction anchors are generally used to attach walls to foundations. Anchor systems are often used to help protect the structure against damage from high winds by adding more strength and stability. Factors such as wind shear, weight, soil type, and foundation conditions will affect the type of anchor system chosen.

One type of construction anchor is an anchor bolt. Bolts are threaded pieces of metal used with nuts and usually either washers or metal plates, both of which distribute the bolt's holding strength over a larger area. Large bolts are set into the foundation to serve as anchors. They secure the bottom of the wall to the concrete.

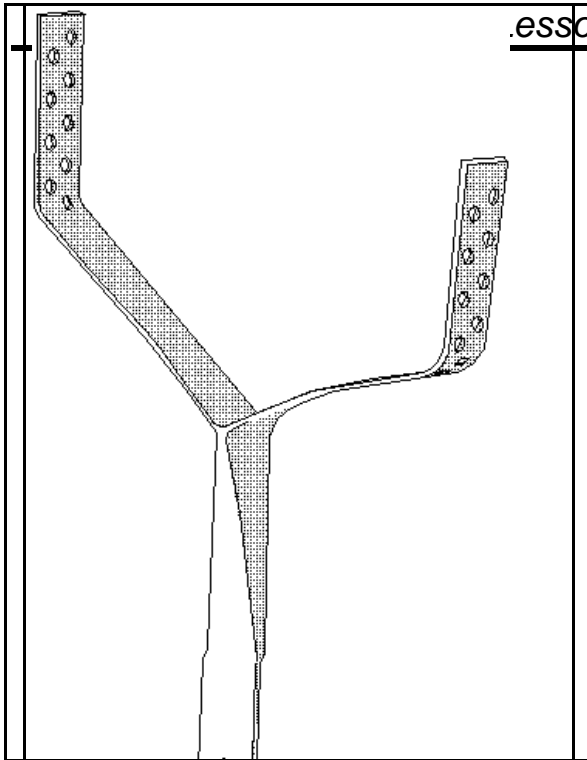

Various types of anchor systems can also be used. One type of anchor involves metal straps set in concrete and then attached to the wooden member in the wall; an example is shown in Figure 4.5. Other designs involve anchors screwed into the ground with metal cables attaching them to the structure.

Framing Anchors

Framing anchors differ from construction anchors in that they attach framing pieces together. Usually, they are used for activities like setting joists in place, attaching the roof to the walls, attaching walls to each other, and joining the parts of a truss together. The anchors therefore have specific shapes for a particular purpose. Figure 4.6 shows some different types of framing anchors.

Summary

Nails, screws, adhesives, and anchors are the most commonly used fastener groups. Nails are the most common and come in sizes and

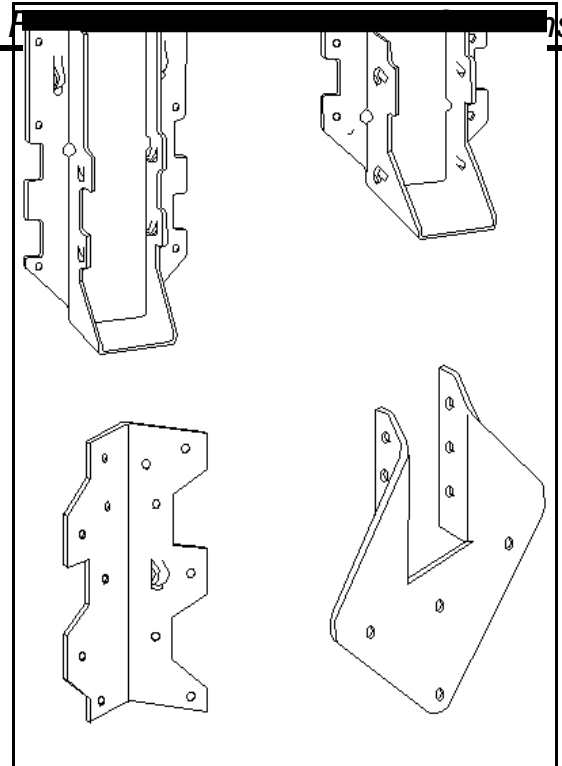

styles appropriate for nearly any situation. Screws also come in a vast assortment of sizes to meet the many demands placed on them. Adhesives are becoming more cost effective and useful for many types of materials and may replace many of the other fasteners in the future.

Anchors are used to attach walls to foundations and join framing members.

Credits

Huth, Mark W. *Construction Technology*. 2nd ed. Albany, N.Y.: Delmar Publishers, Inc., 1989.

Lindley, James A., and James H. Whitaker. *Agricultural Buildings and Structures*. Rev. ed. St. Joseph, Mich.: American Society of Agricultural Engineers, 1996.

Wagner, Willis H. *Modern Carpentry*. South Holland, Ill.: Goodheart-Willcox Co., Inc., 1987.

Lesson 5: Floors and Subfloors

The needs of the structure are the primary factor in determining what type of floor will be best for that structure. This lesson explores some of the basics of constructing floors. However, concrete, one of the most popular types of floors for agricultural structures, is not covered here.

Floor Framing Members

Floor framing is the structural portion of the building that rests on the concrete foundation and attaches the building to it. The framing forms the base of the structure. Floors consist of a number of components. Figure 5.1 shows some of these parts.

Crawl space - The crawl space is found between the ground and the first floor in structures without a basement.

Sill plate - This term refers to a piece of material, usually made of wood or metal, that is attached to the foundation. A wood sill plate is usually a 2-inch thick board that is 4, 6, or 8 inches wide. The sill plate is the place where the building frame attaches to the foundation. It supports the floor joists.

Girder or beam - If floors are too wide to be spanned across their full width by one piece of

material, girders or beams are used to support the structure. They may be large pieces of dimensional wood, a combination of dimensional wood and plywood, metal, or some fabricated combination of metal and wood. Girders support the weight of the structure at certain points along their length. These girders are supported at intervals by posts. Girders and their supporting posts are generally used for structures with floor spans of more than twelve feet. The girders are attached together using metal plates and bolts.

Post - The posts that support the girders may be made of wood, metal, or concrete. If the supports are made of concrete, they are referred to as concrete piers, while metal posts are often pipes, called pipe columns.

Header joist - The header joist attaches to the sill to form a box sill. It also attaches to the ends of the joists.

Joist - A joist is the wood or metal member that rests on the sill and supports the first layer of flooring and the weight of the structure. Floor joists are typically made of 2" x 8", 2" x 10", or 2" x 12" boards.

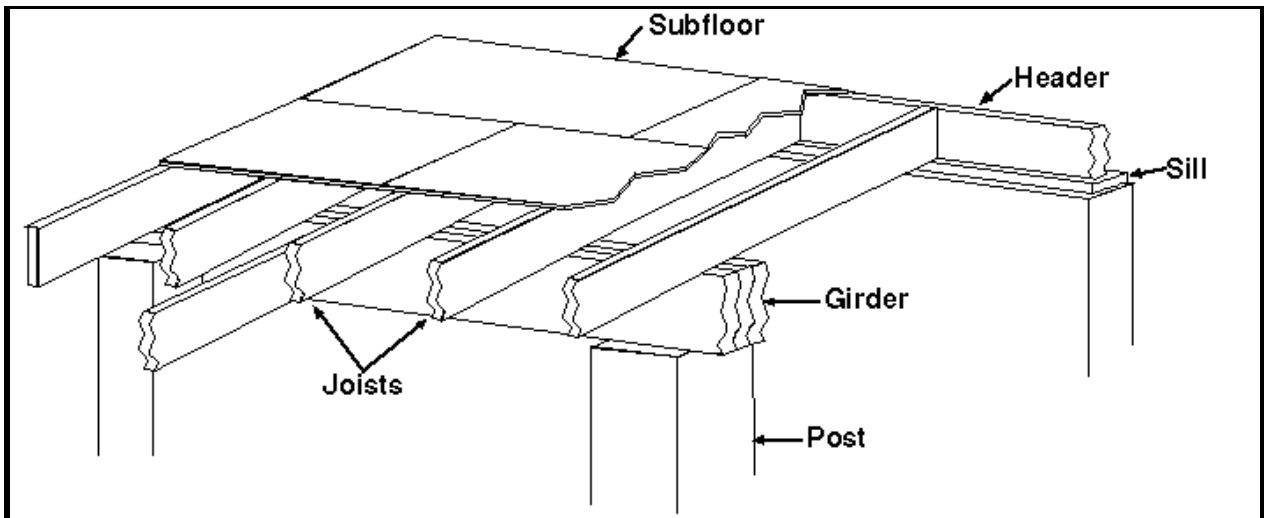

Building Construction

Bridging - Bridging are small wooden or steel

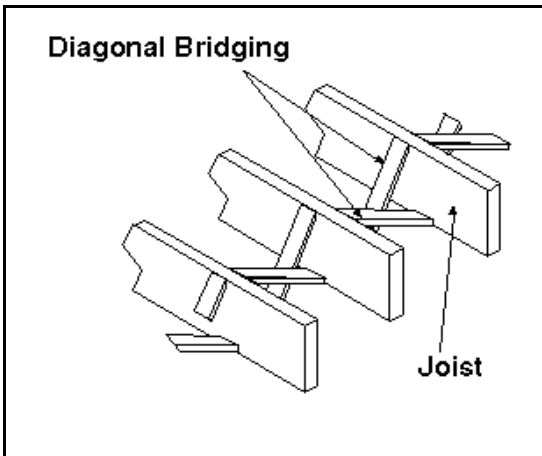

pieces fitted in pairs between the joists. They are crossed to reduce movement of the joist and help distribute weight. Figure 5.2 illustrates bridging.

Subflooring - Subflooring is the first layer of material applied over the floor joists. The most common subflooring is some type of sheathing material, usually plywood, particle board, or waferboard. The material typically has a thickness of at least $\frac{1}{2}$ an inch and is usually $\frac{1}{2}$ or $\frac{3}{4}$ of an inch. Thicker material or dimensional lumber may also be used. The subflooring lies under the finish floor, which is the final layer of flooring consisting of vinyl flooring, carpeting, wood, linoleum, or other types of flooring.

Underlayment - The underlayment is a second layer of material attached to the subflooring to strengthen the floor. It is usually made of plywood. Sometimes a heavy subflooring is used and the underlayment is not necessary.

Placement of Floor Joists

Construction of a floor begins with attaching a sill plate to the foundation or basement walls. The sill plate is most commonly attached to the foundation with anchor bolts embedded in the concrete. Once the sill plate is bolted down, marks can be made on it to indicate the placement of joists. The spacing of joists varies with the weight of the structure, dimensions of the material, and type of material.

After the sill is in place, the header joist should be cut to length and nailed in place along the

outside perimeter of the sill plate. The header joists should be attached standing on the 2-inch edge of the board. They will then form a box sill. Header joists tie the other joists together, increasing the strength of the floor.

The joists running the length of the floor are called stringer joists. The stringer joists are also set on edge and are fastened to the header joists using nails or screws. The joists are spaced an even distance apart, usually 16 inches measuring from the center of one joist to the center of the next. This spacing determines the final strength of the floor. If a joist will be below a weight-bearing wall, another joist should be placed against it for added strength.

If the joists are longer than 8 feet, support beams or girders are typically placed under the joists to help support the structure. When joists meet at a beam, a metal joist bracket and bolts are used to attach the ends of the two joists together.

Bridging is added between joists. Metal bridging pieces may be used, or boards may be cut and nailed in place to join the bottom of one joist with the top of the adjacent joist, forming an "X" between the two joists. Bridging decreases the movement of joists from side to side, allowing the floor to give when weight is placed on it. Cross bridging will also strengthen the joists, helping to support the weight of the structure.

Installation of Subflooring

Once the joists have been fastened together, the subflooring can be installed. The sheets of subflooring are placed at a 90-degree angle to the joists. The edge of the sheet should rest on a joist, covering half of the joist. Another sheet of subflooring can then be joined next to the first sheet, with both sheets attached to the joist. The sheets of subflooring should be placed with a gap of at least $\frac{1}{8}$ of an inch between them. The gap will allow for expansion and contraction of the sheets due to temperature changes. If this gap is not included, the edges of the subflooring may work upward due to the pressure.

The sheets of subflooring are typically attached to the joists with the fasteners about 8 to 12 inches apart. Using more fasteners will decrease later "squeaking" from subflooring that is loose and moving up and down against another sheet or the shank of the fastener. If extra holding strength is desired, glue may be placed on the tops of the joists before the subflooring is laid down.

When placing subflooring on a large floor, the place where the seams come together should be staggered or offset to give more strength to the floor. Staggering the seams may require cutting a smaller piece to start one strip of subflooring.

Load and Types of Flooring and Subflooring

Load is the weight carried by any part of a structure. Load can be classified into three categories: dead, live, and environmental. Dead loads refer to the vertical weight of a structure. They consist of the total weight of all the permanent parts of the structure, including the foundation, footings, lumber, and electrical and plumbing apparatuses. Dead loads act constantly. In contrast, live loads are considered to be temporary and intermittent. Live loads are the weight or pressure from static and dynamic loads. Static loads come from anything occupying the structure, such as livestock, equipment, or stored products. Dynamic loads come from the operation of equipment like a tractor or handling equipment in the structure. Environmental load is caused by natural factors, such as wind, snow, and earthquakes, that result in weight or pressure on a structure.

To determine what materials and spacing to use in the flooring, calculate dead load plus the maximum expected live load. If the floor will be supporting average loads, the joists can be placed 16 inches apart with $\frac{3}{4}$ -inch subflooring. If heavier loads will be placed on the flooring, the joists should be spaced only 12 inches apart with 1-inch subflooring. For heavy loads, two layers of subflooring will often be placed on the joists for additional strength, increasing the thickness of the subflooring to $1\frac{1}{2}$ inches or more. The second layer of subflooring is placed at a 90-degree angle from the first layer. Heavier loads also will generally require wider joists, and 2" × 12" joists can be used if the loads are very

heavy. For heavy loads, metal members, large timbers, or combinations of metals, dimensional lumber, and possibly plywood are needed to construct floors.

Several sources of information are available to help select the right materials and construction for different loads. Tables are available in many construction reference books to determine the ideal components for a building's total load. Most manufacturers of the materials used for this type of construction have recommendations that either are on the material or are made available by their retailers. Commercially prepared plans usually contain all the information necessary to purchase suitable materials and construct a building.

Summary

Floor framing forms the base of a building and attaches the structure to its foundation. Floors consist of many members that must be carefully constructed in order to provide the proper support for the structure. Loads will determine what materials are used and how the floor is constructed.

Credits

Huth, Mark. *Construction Technology*. 2nd ed. Albany, N.Y.: Delmar, 1989.

Lindley, James A., and James H. Whitaker. *Agricultural Buildings and Structures*. Rev. ed. St. Joseph, Mich.: American Society of Agricultural Engineers, 1996.

Boyd, James S. *Buildings for Small Acreages*. Revised by Carl L. Reynolds. Danville, Ill: Interstate Publishers, Inc., 1996.

Lesson 6: Walls

Walls add to the structural integrity of the building and increase weather protection. This lesson will describe some basics of wall construction and types of walls in common use. The focus is on wood construction, although metal is generally used in the same manner for frame construction.

Three Purposes of Walls

Although walls may serve many specific purposes, they have three main functions. They support vertical loads, which consist of pressure from the weight of the walls and the roof exerted downward due to gravity. Walls also resist lateral loads, or pressure exerted from the side. Lateral loads are produced by wind and other weather and by uneven settling of the building, which causes the wall not to be vertical. Finally, they provide protection from the weather. Walls are able to achieve these purposes because of the materials they are made from and how they are constructed.

Types of Wall Construction

The two types of wall construction that are common in agricultural structures are pole frame and stud frame construction. Pole frame construction, which is illustrated in Figure 6.1, involves the use of fewer but heavier members. Poles or posts form the main structural members of the wall. Horizontal pieces of dimensional lumber called laths or girts are attached to the poles. Siding, usually metal sheets or dimensional lumber, is placed vertically on the structure by attaching it to the laths.

Stud frame walls use studs, which are the vertical wall members that provide the main support for the wall, in their construction. The methods of construction used for wood or metal stud frame walls are similar. The spacing and size of the members, material used for siding, and interior cover materials are the major differences. Figure 6.2 shows an example of a stud frame wall.

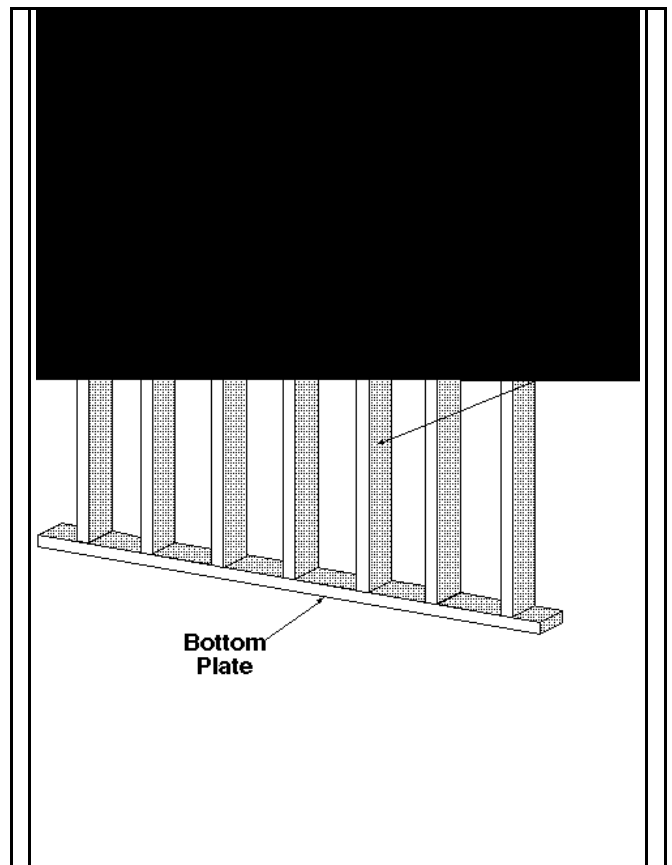
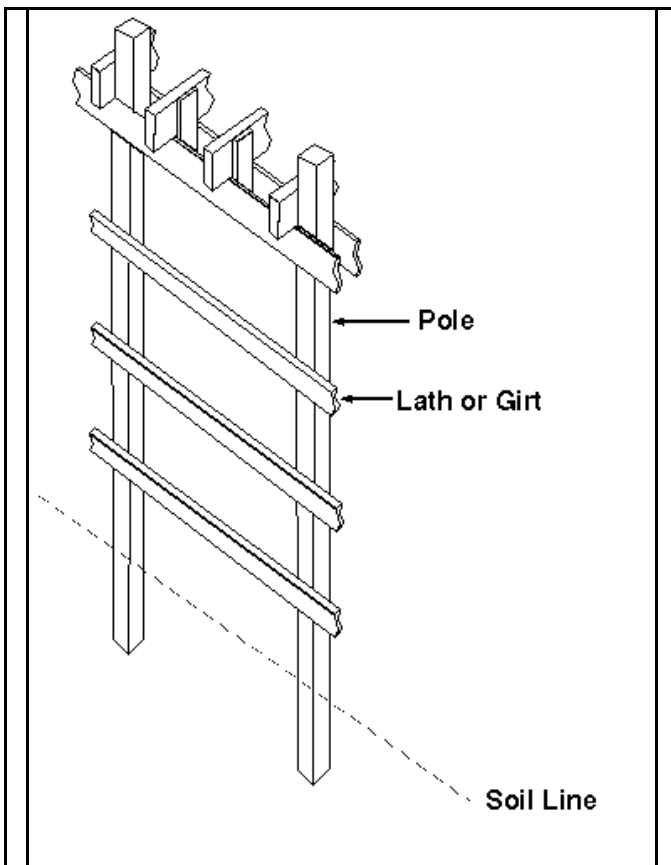

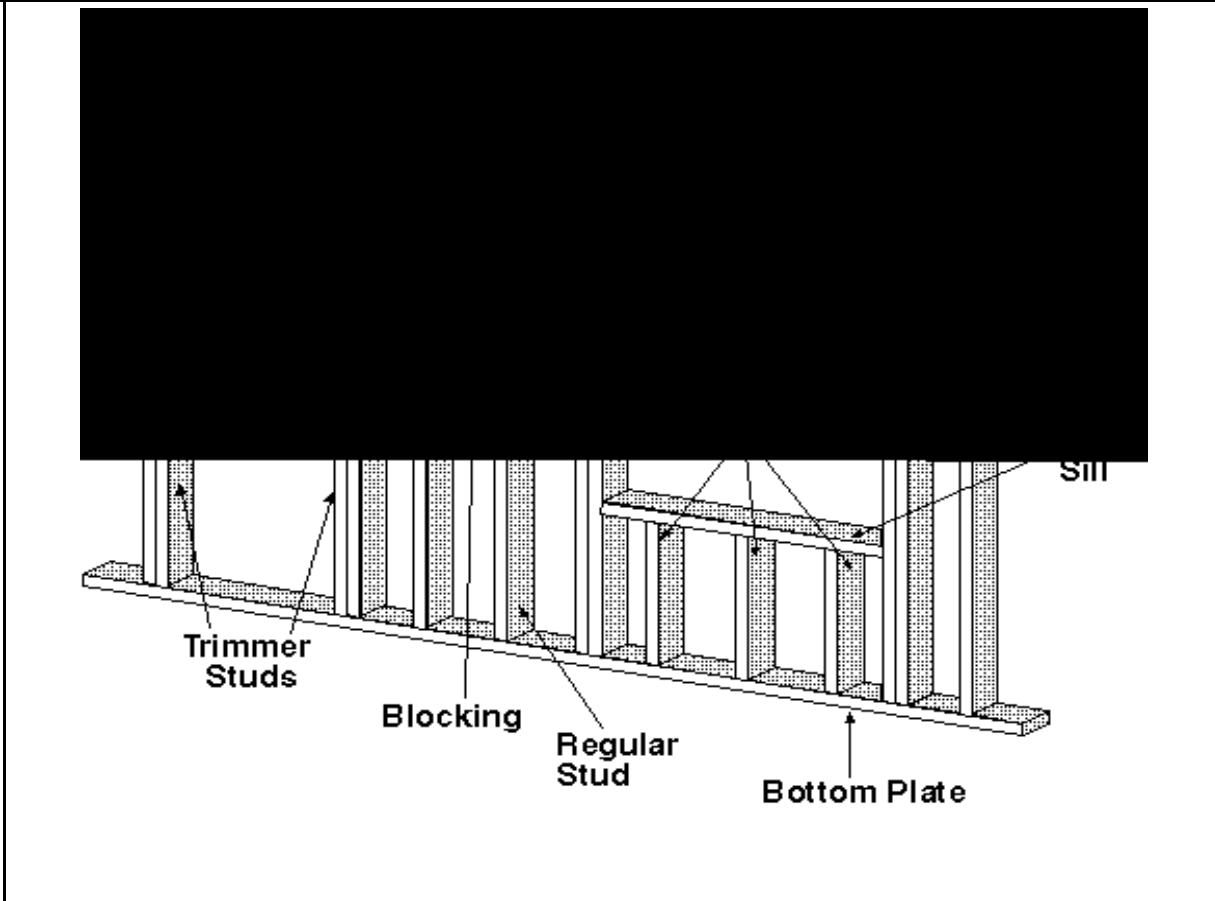

Components of a Frame Wall

Frame walls consist of a number of structural components. Figure 6.3 illustrates different wall members.

Top plate - The top plate is the horizontal member at the top of the wall. The trusses or rafters rest on the top plate.

Sole plate - This structural member forms the bottom of the wall. The studs are nailed to the sole plate.

Stud - As discussed in the preceding section, a stud is the vertical wall member that provides the main support for the wall. Studs, which may be made of metal or wood, are nearly always placed on 16 or 24-inch centers to take advantage of commercial sheathing material dimensions.

Rough sill - A rough sill is a horizontal framing member attached to the top of the jack studs to form a rough base for a window.

Diagonal brace - Diagonal braces temporarily add to the rigidity of the wall, making it stronger. The bracing is used during wall construction to keep the walls square and vertical. To form the brace, a 2" board is nailed diagonally from a top corner to the opposite bottom corner of the wall. The braces are removed later as the siding and sheathing are put on the wall.

Header - A header is a horizontal piece found above openings for doors and windows. It provides support for loads over the opening.

Trimmer stud - Trimmer studs are vertical framing members that form the sides of door and window openings as well as rough openings. They support the header.

Jack stud or cripple stud - Jack studs are studs that are shorter than full length used below windows and above windows and doors.

Blocking - Blocking refers to the wooden blocks that are used to fill in the space between framing members, providing support.

Siding - Siding is material placed on the outside of a building to seal and enclose the building from the weather, serving as insulation for the structure.

Interior covering - This covering consists of material placed on the inside of the wall. Generally sheetrock is used for houses, while barns and other buildings may use plywood.

Wall Construction

Walls are typically constructed one wall or section of a wall at a time, with the wall laying flat on the ground. To begin construction, the length of the wall is determined, and the top and bottom plates are cut to that length. The studs are nailed between the top and bottom plate using two nails at each end of the stud. They are spaced an equal distance apart, usually 16 inches. The spacing of the studs determines the overall strength of the wall and its ability to support the weight of additional floors or the roof.

Buildings with less weight on the walls are sometimes constructed with the studs 24 inches apart. At the corners of a building, double studs are nailed side by side. These double studs allow the two walls that form the corner to be attached to each other by providing a wider base to which to nail the 2" × 4" stud from the other wall. Diagonal braces and blocking attached between the studs add to the rigidity of the wall, making it stronger. When the wall is finished, it is stood upright and attached to the foundation or subfloor using nails or bolts. Walls are then nailed together at the corners. Finally, the diagonal braces can be removed.

If the wall has windows or doors, they require additional components. Window framing usually requires a header as well as extra support from trimmer boards at the sides of the opening. Window openings generally also use jack studs and a rough sill, as shown in Figure 6.3. Like window framing, door framing involves the use of a header, extra supports on the sides, and sometimes jack studs.

Types of Siding

Dimensional lumber is sometimes used as siding. The siding may consist of 1" × 12" boards or other similar sizes. Dimensional lumber

accepts paint or stains readily, allowing customization. The lumber will degrade due to weather. However, it can be treated to be weather resistant, increasing the life of the lumber.

Exterior plywood is also used as siding. Because it is sold in larger sheets, fewer seams will exist, aiding in insulating the building. The plywood is also easier to apply than dimensional lumber. The plywood is cheaper than other forms of siding, but it is also not as attractive.

Hardboard sheathing, also called Masonite, may be used for siding on buildings. This style of sheathing is sold in sheets that come in a number of colors. Hardboard siding provides some insulation and is relatively easy to apply. One disadvantage to this style of siding is that hardboard is somewhat brittle and does not easily withstand stress from impacts, temperature changes, and other factors.

Metal siding, which is commonly made of galvanized steel or aluminum, is frequently used on structures. The siding comes in sheets that are normally at least 3 feet wide and 8, 10, or 12 feet long. The advantage to this sizing is that there are fewer seams, allowing for better insulation and weatherproofing than with other types of siding. Metal siding lasts for a very long time and does not need to be replaced as often as wood. Metal siding can be painted but not stained.

Vinyl siding is commonly used on houses and garages. This style of siding consists of strips that overlap, sealing the building. The siding is available in a variety of colors. Vinyl siding has a relatively long life but is more expensive than other types of siding.

Masonry products like bricks and cinder blocks are sometimes used as siding. They have decorative value and last for an extremely long time. The cost of the materials is moderate, but masonry products are more difficult to apply.

Fiberglass, glass, and plastics are used as siding in certain situations. One common example is a greenhouse, where light in the building is desirable. These materials can be purchased with

Building Construction

varying levels of clarity, from totally clear to mostly opaque.

New siding materials are being developed and marketed. Many of these products are simply improved versions of traditional materials that might offer benefits such as a heavier weight or more weather resistance. Some products, like fiberglass/epoxy glazes that are sprayed or troweled on a surface, are the result of technological advancements.

When selecting siding, consider the grades and weights available, the fire resistance of the material, its expected life span, and its maintenance requirements. Manufacturers and retailers should have additional information on the specific advantages each type of siding may offer.

Summary

Walls serve to support the structure's vertical and lateral loads as well as to protect the inside of the

building from the weather. Walls generally are constructed using either pole frame or stud frame construction. Stud frame construction is the more complicated of the two; frame walls consist of a number of components. While many siding options exist, most frequently some type of metal, vinyl, or wood product is used.

Credits

Huth, Mark W. *Construction Technology*. 2nd ed. Albany, N.Y.: Delmar Publishers, Inc., 1989.

Lindley, James A., and James H. Whitaker. *Agricultural Buildings and Structures*. Rev. ed. St. Joseph, Mich.: American Society of Agricultural Engineers, 1996.

Table 7.1 - Pitch and Slope

Lesson 7: Roof Support Systems

Lesson 7: Roof Support Systems

Roof support systems in agricultural structures generally involve some type of rafter system. This lesson will explore the different components of rafter systems, their function, and their construction. An overview of different styles of roofs will be presented as well since roof styles are determined by the roof support system's configuration.

Trusses and Rafters

A truss is a structural assembly of lightweight material consisting of connected triangles formed by rafters, joists, or beams that is used to create a system designed to support heavy loads over a

Pitch	Slope
1/8	3:12
1/6	4:12
1/4	6:12
1/3	8:12
1/2	12:12

designed for a specific structure that are transported to the construction site and mechanically placed in position on the structure. Figure 7.1 is an example of a truss.

A rafter is a structural member that spans from a wall's top plate to the ridge board of the roof to support the roof, as shown in Figure 7.2. In common terminology, rafter generally describes a site-built truss-type system. As shown in the



considerable span. Trusses may be made of wood, wood products, metal, or a combination of any or all of these materials. Truss designs will vary depending on the needs of the structure. For the purposes of agricultural construction, trusses are nearly always prefabricated units. The ability to safely support roof loads, including live loads from ice, snow, or wind and the dead load of the material, is critical to a roof support system. Load is therefore an important consideration when selecting a roof system. The choice of a roof system will vary depending on the weather of the geographical area, which will determine the wind and snow loads on the structure. Different materials and roof designs have varying load capacities. General information about load and roof systems is available from construction reference materials or in professionally prepared construction plans. In recent years, the industry of prefabricated trusses has eliminated much of the need for working with this information. Reputable truss companies have engineers or other professionals on hand to design roof support systems for specific structures.

Figure 7.1, rafters are part of a truss system, and a "trussed rafter" is the correct term for a truss.

Selecting a Roof System

The economics of cost and labor are another factor to consider when selecting a roof system. Truss companies will build to order, and generally they provide this service at a cost equal to or less than the cost of manufacturing systems on site. Roof support systems for smaller structures may be built on site at a savings, however. When making these decisions, the labor involved in cutting and assembling systems as opposed to buying prefabricated units must be considered.

Pitch

Pitch is a term used to describe a roof's steepness. The pitch of a roof can be flat to very steep. Architects, engineers, or other building professionals can determine if a given pitch is acceptable for supporting loads and provides an efficient use of material.

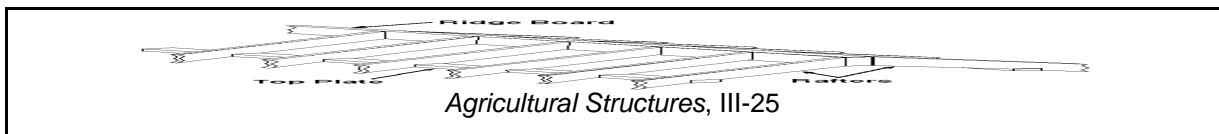

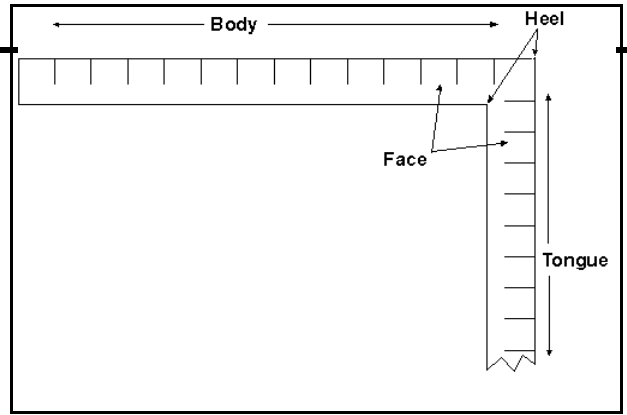
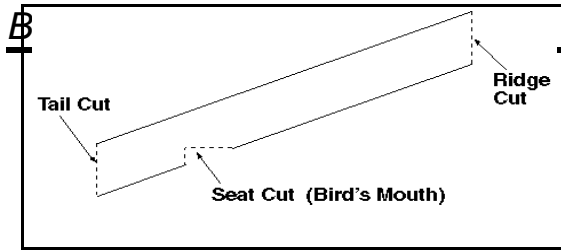

In order to calculate pitch, the rise and run of the roof must be known. Rise is the vertical distance from the top plate to the ridge. Run is the horizontal distance covered by one rafter from the outside edge of the top plate to the exact center of the ridge. Span is the total distance from the outside edge of one wall to the outside edge of the other wall. Span is equal to twice the run. All measurements of rafters are made relative to a measuring line that runs parallel to the side of the rafter and extends from the middle of the ridge board to the outer edge of the top plate.

Pitch may be defined as a fraction that is a ratio of the rise to the span. Pitch may also be expressed as slope in a ratio of the number of inches of rise per foot of run. Table 7.1 shows relationships between pitch and slope. An example of slope is 6 in 12, or 6:12, meaning six inches of elevation for every twelve inches of

length, as shown in Figure 7.3. As illustrated in the diagram, slope is shown using an inverted right triangle and the accompanying rise and run numbers.

Common slopes for a roof are 4:12, 5:12, and 6:12. Buildings where snow buildup or storage space above trusses is not a concern commonly use 4:12 slopes, because the roof does not need to be as steep. A slope of 6:12 is used where storage space is desirable or snow loads are heavy.

$$Pitch = \frac{Rise}{Run}$$

When expressing pitch as a fraction, the degree of pitch is calculated using the formula shown. A roof with a rise of 6 feet and a run of 12 feet has a pitch of $\frac{1}{2}$.

Parts of a Rafter

A rafter is a piece of dimensional lumber that constitutes the main member of a roof support

system. Rafters are commonly made of 2" x 8" or 2" x 10" boards in the desired lengths. The tail, or overhang, is the part of the rafter that forms the part of the roof from the side of the building to the end of the roof. The other parts of a rafter are the cuts made to allow the rafter to fit properly in the roofing system. Rafters have three kinds of cuts, as illustrated in Figure 7.4, which shows the positions and angles of these cuts. A tail cut is made at the end of the rafter and is parallel with the wall. A seat cut, sometimes referred to as a bird's mouth, is a notch cut out of a rafter that allows the rafter to be seated on the top plate. The ridge cut, also called a plumb cut, is made at the end of the

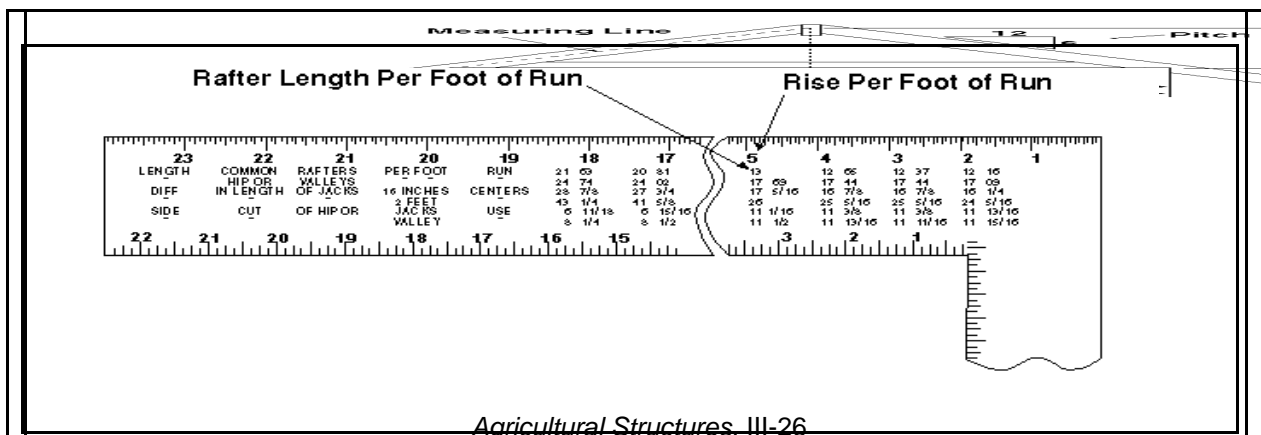

Lesson 7: Roof Support Systems

rafter that fits against the ridge board and allows the rafter to fit flush against the ridge.

Rafter Layout

Rafter layout most commonly involves the use of a framing square (Figure 7.5). The face of the square is the side seen when holding the tongue of the square in the right hand with the body of the square in the left hand. The rafter table, shown in Figure 7.6, is used to determine the length of the rafter. To lay out a rafter, the rise and the run are needed. First, the number that indicates the rise per foot of run on the "inch" line on the body of the framing square must be located. In the rafter table beneath this number is a number indicating the length of a common rafter per foot of run; a space between these numbers is read as a decimal point. This second number is multiplied by the number of feet of run. The desired length of the tail is added, and one-half the thickness of the ridge board is subtracted. After rounding as needed to the nearest $\frac{1}{4}$ inch, this number is divided by 12 to find the length in feet and inches.

As an example, suppose rise per foot of run is 5 inches. The table in Figure 7.6 indicates that the length of a common rafter with a rise of 5 inches is 13 inches per foot of run. The run for the roof, including the amount of projection, is 14 feet. Fourteen multiplied by 13 is 182 inches; subtracting $\frac{3}{4}$ inches for half the thickness of the ridge board leaves 181.25 inches, or 15 feet, $1\frac{1}{4}$ inches.

Once the length has been established, the various cuts can be made on the rafter. The tail cut is made at the end of the board that

points to the left, as in the illustration. Various tables and scales are found on this versatile tool.

Even inexpensive squares include tables for rafters and graduated scales of $\frac{1}{6}$, $\frac{1}{2}$, $\frac{3}{4}$, and $1\frac{1}{4}$, which are common pitches. These scales provide specific information on laying out cuts for these pitches.

overhangs the structure, as shown in Figure 7.7.

The measuring line is marked in the center of the rafter material. Then the correct length of the rafter is measured and marked along the line.

The square is placed on the material and the number 12 on the body is aligned with the top of the board to indicate the run. The framing square is pivoted until the number 5 on the tongue, indicating the rise, aligns to the top edge of the board. The outside edge of the tongue must be even with the mark made along the measuring line to represent the length of the rafter. The tail cut is marked along the outside edge of the tongue. The rafter is then cut.

The ridge cut is made in the same manner as the tail cut but at the opposite end of the material. Again, the outside edge of the tongue must be aligned with the mark indicating the length of the rafter found at this end of the measuring line.

The seat cut is made by first measuring the length of the tail and marking this point on the measuring line. The depth of the seat cut is usually the same as the thickness of the piece of material used in the top plate, most commonly $1\frac{1}{2}$ to 3 inches. The material with the edge to be cut is laid facing the opposite direction. The framing square is placed on the material with the body pointing to the right and the tongue pointing

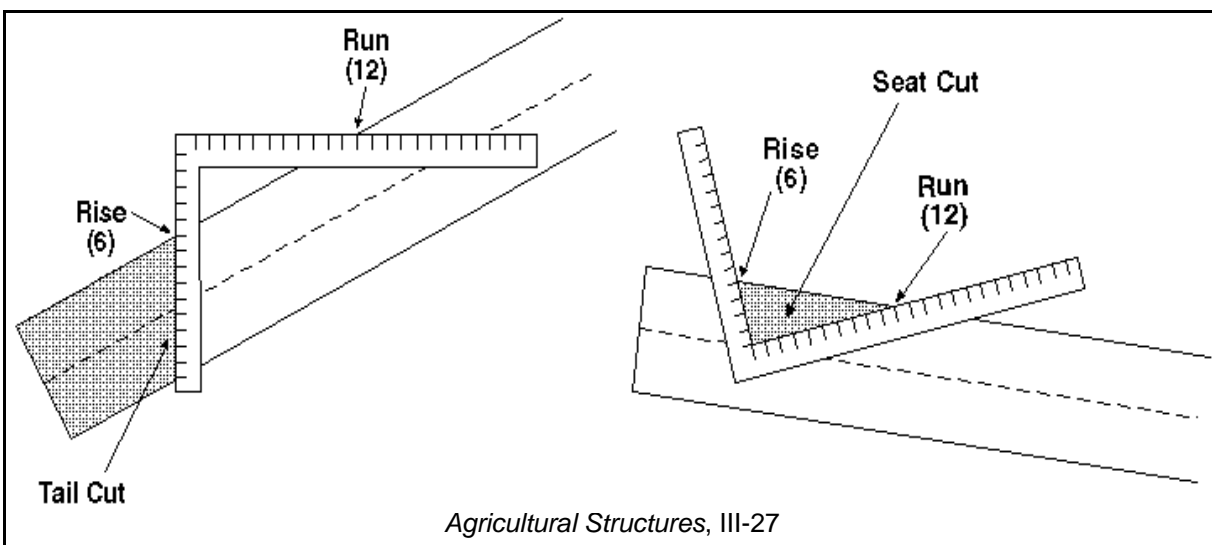

Building Construction

up. The inside edge of the tongue is aligned to the mark indicating the length of the tail and the tongue is adjusted until the rise and run correspond with the edge of the board. The wedge-shaped section is marked and cut out.

Constructing a Top Plate

Top plate construction is generally a simple procedure. Dimensional lumber of the same size used for the wall studs, usually 2" × 4" or 2" × 6" boards, is attached to the tops of the studs. Often a second piece of the same material is attached to increase strength and stability. If the top plate is doubled, the joints of the layers should not overlap; staggering the joints will further increase the strength of the structure.

Ordering Trusses

Ordering trusses is made easy with the help of professional representatives from the manufacturer. These people are able to make suggestions and explain the options. Perhaps

The top plate is a wall member that is usually made of the same material as a wall's studs. It is attached to the top of the studs. Rafter seat cuts fit over the top plate, connecting the wall to the roof support system.

the most important information to supply to a truss manufacturer is a copy of the building's plans, which will provide all the technical information needed, including span, run, rise, and pitch. The builder will probably also want to be told the type of roofing material to be used, although this information may not affect the design. Other important information the truss manufacturer will need is the desired delivery date and time and, if a representative has not been on the building site, exact directions.

Roof Styles

The most common types of roof styles used in agricultural structures are shed, hip, gable, gambrel, mansard, quonset, and gothic, or

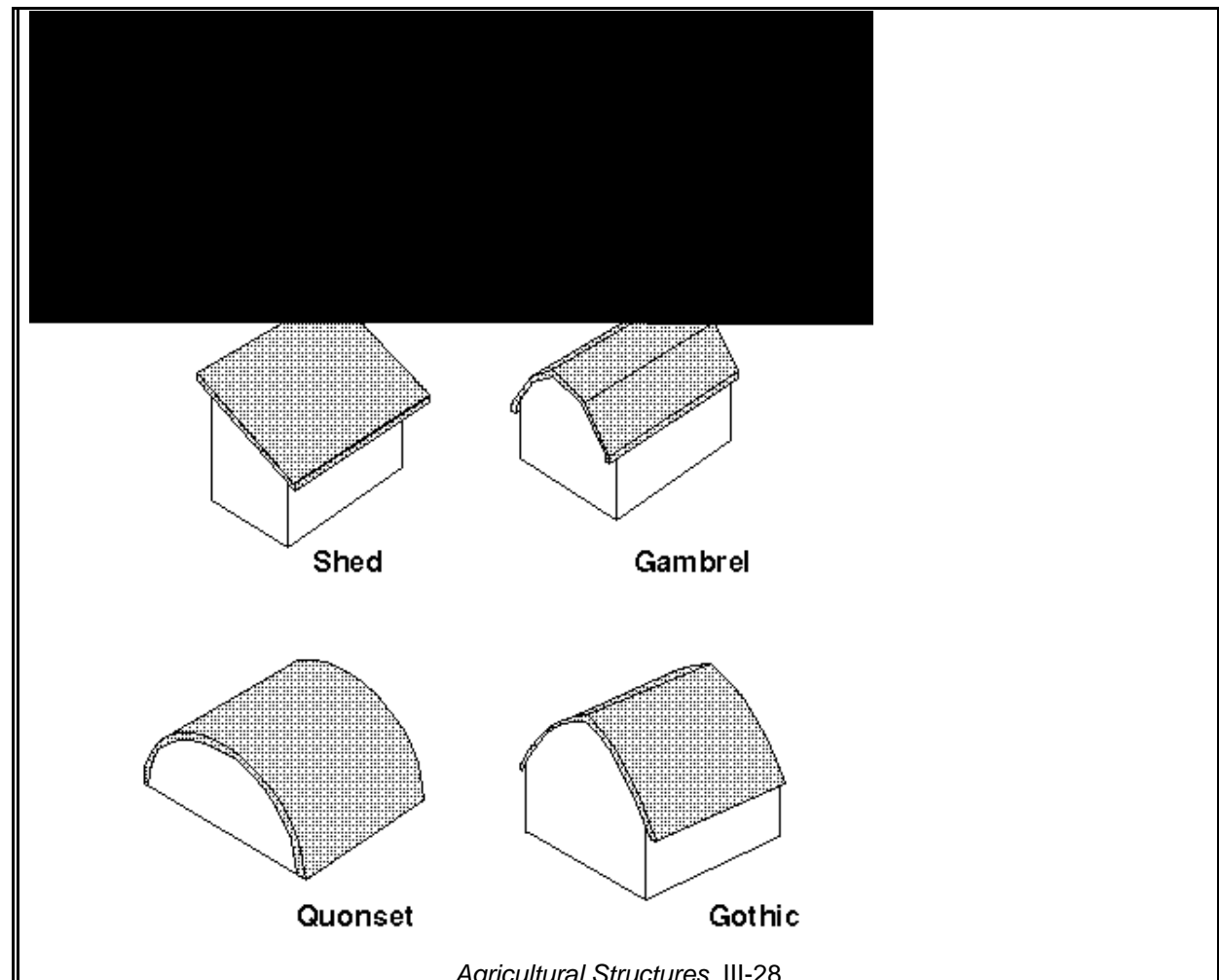

Lesson 7: Roof Support Systems

arched. (Figure 7.8). These roof types were introduced in Lesson 2 of this unit. Any of these styles or combinations of styles may be found in most areas. As was previously discussed, the choice of a particular roof style is based on the structure's function, personal preferences, and Shed - A shed roof has only a single pitch. This type of roof is usually found on smaller structures of 2,000 square feet or less. It has the advantage of being inexpensive to construct and simple to frame and install. Because the slope of the roof is relatively shallow, it is able to resist winds well.

Hip - Hip roofs have an attractive appearance. However, they are difficult to frame and install. Poor ventilation of attic areas can also be a problem.

Gable - Gable roofs are very common and are often used for agricultural structures. They are relatively inexpensive and easy to frame. If the pitch of the roof is not too steep, this design may be extremely wind resistant.

Gambrel - Gambrel roofs use two different pitches, with the top pitch being approximately 30 degrees and the bottom pitch around 60 degrees. It is used for barns, because the design provides the advantage of spacious overhead room for storage. However, these roofs can be expensive and are more difficult to construct. They also are less resistant to damage from winds.

Mansard - Like hip roofs, the mansard roof style is regarded as having an attractive appearance. One potential problem with this type of roof is that it leaks more easily because of the shallow pitch of the roof.

Quonset - A Quonset structure has no flat surfaces. Instead, the structure forms a semicircle with an arching roof. Quonset buildings are usually sold as a package and are therefore easy to construct.

Gothic/arched - In a Gothic or arched roof, two curving arches meet at a point. Some

affordability. If proper planning and materials are utilized, all the roof styles are comparable in function in regard to protection from the elements.

structures with this type of roof are similar to Quonset buildings in that they have no walls; the arches make up the sides of the building as well as the roof. However, a Gothic roof may be used for other types of buildings, such as barns, that do have distinct walls. The arches create a strong roof with large storage volume.

Summary

Roof support systems generally consist of either trusses or some other type of rafter system. Systems may be prefabricated and ordered from a manufacturer or built on site. The type of roof system chosen will depend on load, cost, and labor considerations. One important aspect to consider for any roof is its pitch, or steepness. Several different roof styles may be used.

Credits

Ball, John E. *Tools, Steel Square, and Joinery*. Vol. 1 of *Carpenters and Builders Library*. Revised by John Leeke. New York: Macmillan Publishing Co., Inc., 1991.

Boyd, James S. *Practical Farm Buildings*. 3rd ed. Revised by Joshua L. Reynolds. Danville, Ill.: Interstate Publishers, Inc., 1993.

Burch, Monte. *How to Build Small Barns and Outbuildings*. Pownal, Vt.: Storey Communications, Inc., 1992.

Huth, Mark W. *Construction Technology*. 2nd ed. Albany, N.Y.: Delmar Publishers, Inc., 1989.

Lindley, James A., and James H. Whitaker. *Agricultural Buildings and Structures*. Rev. ed. St. Joseph, Mich.: American Society of Agricultural Engineers, 1996.

Lesson 8: Roofing Materials

Roofing materials come in a variety of forms. For agricultural structures, three types of roofing materials are commonly used. While all of them can offer good protection from the weather, each has its advantages and disadvantages.

Types of Roofing Materials

The three types of roofing materials most commonly used in agricultural structures are fiberglass shingles, asphalt in roll or shingle form, and metal roofing. Asphalt is a combination of crushed rock and an adhesive. Asphalt shingles are used extensively on homes. Metal roofing can be made of steel, tin, aluminum, or copper. Steel roofing is commonly used and is available in either galvanized or painted form. Galvanized metal is metal that is coated with zinc oxide to prevent rusting. Painted or galvanized metal roofing is commonly used on machine sheds and other agricultural structures.

Other materials, like cedar shingles or tile, are sometimes used but generally only for cosmetic reasons; they can be quite costly.

Roofing material is sold by the square, a square being equal to 10 feet by 10 feet, or 100 square feet of finished roofing. The delivery of roofing materials to the work site is often an option and may be worthwhile, since most delivery trucks are equipped to deliver materials to the rooftop, which is an advantage when dealing with a large amount of roofing material. Knowing the roofing material's warranty and how the roofing must be installed to comply with the warranty agreement is important. Factors such as proper roof ventilation may be required if the warranty is to be valid.

Advantages and Disadvantages of Roofing Materials

Before choosing a roofing material for a particular structure, the advantages and disadvantages of each type of material available should be assessed. Longevity, cost, and maintenance requirements are some factors used when evaluating roofing materials.

Asphalt roofing material has the advantage of being lower in cost than either metal roofing or fiberglass shingles. Asphalt in roll form usually

costs the least of the different types of roofing materials discussed in this lesson; it is often considered the least attractive as well. An advantage of asphalt in roll form is that installation is simple. A disadvantage of asphalt roofing material is its relatively brief life span in comparison with the other types. While different brands may vary in their life span, under normal conditions they last for 15 to 25 years. Proper maintenance will involve refastening materials that come loose and repairing any leaks that develop. Another disadvantage of asphalt roofing is that it will burn readily.

Fiberglass shingles are moderate in cost; they are more expensive than asphalt products but cost less than painted metal roofing materials. They also have a longer life span, around 30 years. A disadvantage of fiberglass shingles is that they are flammable. Again, maintenance involves keeping shingles fastened securely and any leaks repaired.

Galvanized metal comes in a variety of lengths, gauges, and ribbings, which are raised areas in the metal that add strength. The material is relatively inexpensive, being comparable in price to asphalt roofing. It is very fire resistant and has a life span of 50 years or longer. Galvanized metal is a very durable material, and maintenance requirements are limited to simply keeping it tightly secured to the roof. To increase its life span, the metal may be coated with rust-retardant roofing protectant, although this material may not be needed for years after the roof's initial installation. A disadvantage of galvanized metal is its plain silver appearance, which may not make it suitable for all uses. Another disadvantage of metal roofing is the noise caused by rain or hail striking the roof, especially in a building inhabited by people or animals, like a house, office, or barn. Noisy barns can be unsettling to some animals, especially hogs.

Like galvanized metal, painted metal comes in a variety of lengths and gauges. However, as its name indicates, it comes in a variety of colors and can be attractive. It is also fire resistant and can have a long life span of 30 or more years, depending on the gauge, finish, and maintenance. Painted metal roofing is generally more expensive than asphalt shingles, galvanized metal, or fiberglass roofing.

Building Construction

Maintenance for both types of metal roofing generally involves keeping the material secured tightly to avoid leaks and keep the wind from tearing off the metal sections. In some locations, periodic washing of the roof may extend the life span considerably. In areas where trees overhang the roof, leaves or bird droppings may accumulate and have a caustic effect on the metal, causing premature rusting.

Structural Components of a Roof

The structural components of a roof include the rafters or trusses that make up the roof support systems discussed in the previous lesson. In addition, roofs using asphalt or fiberglass roofing materials consist of a solid decking system to which the roofing material is attached. The decking may be either some form of sheathing material, such as plywood or oriented-strand board, or dimensional lumber, usually $\frac{3}{4}$ " thick. The decking is nailed or screwed over the top of the roof support system.

Metals may be installed over solid decking, but using decking would increase the cost and weight of the roof system. Instead of decking, purlins are used. Purlins are pieces of dimensional lumber, commonly 1" x 4", in. When attaching asphalt shingles, one of the most common types of roofing, the first step is to nail or staple a layer of building felt, or underlayment, to the roof. Building felt is a tar-soaked fabric that will repel water. It helps to seal the building and prevent leaks. The felt is placed across the length of the roof horizontally starting at the bottom of the roof, with successive layers overlapping about 4 inches. A special metal strip called a drip edge is applied to the bottom and sides of the roof over the underlayment. It prevents moisture

varying lengths. The purlins are nailed perpendicular to the rafters. They provide a surface to which the metal roofing is attached. The spacing of the purlins is dependent on many variables, such as the roof span, the strength of the material used for the purlins, and pitch. Figure 8.1 provides an illustration of the structural components of both types of roofs.

Attaching Roofs

Roofing material in roll or shingle form is usually fastened with galvanized or sometimes aluminum nails. These materials resist rusting, which can cause rust-colored stains on the roof. The nails are usually $1\frac{3}{4}$ inches long, although their length can vary according to the application or the recommendation of the manufacturer of the roofing material. They have a large, flat head to hold the material securely and resist tearing the shingle. Nails are usually used at a rate of approximately 1_ pounds of nails per square of roofing material. Shingles may also come with an adhesive on them to help secure them to the decking. The adhesive is often covered with a paper strip that is pulled off at the time of installation.

from seeping under the underlayment, which would lead to mold or rot.

After the felt and drip edge are in place, the shingles can be applied to the roof, starting at the bottom. Each successive layer or course of shingles will overlap the layers below, allowing water to drain off without the roof leaking. Two types of shingles, T-lock and three-tab shingles, may be used on roofs, although three-tab shingles are the most common.

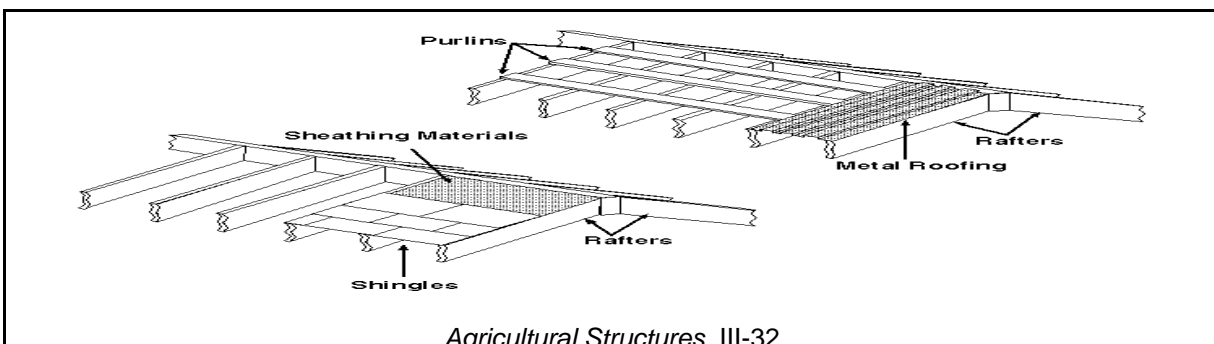

Lesson 8: Roofing Materials

When attaching three-tab shingles, the first course, or starter course, is made of half shingles. The shingle is cut lengthwise along the top of the tabs, making it rectangular. The first shingle in the starter course will need to be cut to a length of 30 inches to offset the end with the first course of full shingles, as shown in Figure 8.2. The long edge of the shingle is placed along the bottom edge of the roof as square to the edge as possible. A hand level should be used to make sure the first course is level. Nails should be applied in the sealer strip that runs lengthwise above the grooves or weeps in each shingle, with one nail on each end of the shingle and above each weep (four or less per shingle).

Once the starter course is down, the remaining courses can be laid. The starter course will be completely covered by the first course of full shingles. The shingles in each remaining course overlap the previous course halfway, or

just above the top of the weeps. The weeps of each course should be equally staggered from the previous course to form a brick-type pattern, illustrated in Figure 8.3. To do this, the first shingle in each course needs to be cut in six-inch increments, producing shingles that are 30, 24, 18, 12, and 6 inches long. These shingles are then laid out along the side of the roof in sequence, starting with a full shingle (36 inches long) and continuing across the roof with full shingles to the other side. The last shingle in the course will be cut even with the side of the roof. The second course will start with a 30-inch shingle, the third with a 24-inch shingle, and so on, creating a pattern that is repeated every six rows. The cut-off material at the beginning of each course may be used at the other end of a course. Any pieces over 12 inches long (a full weep) may be used on the peak of the roof.

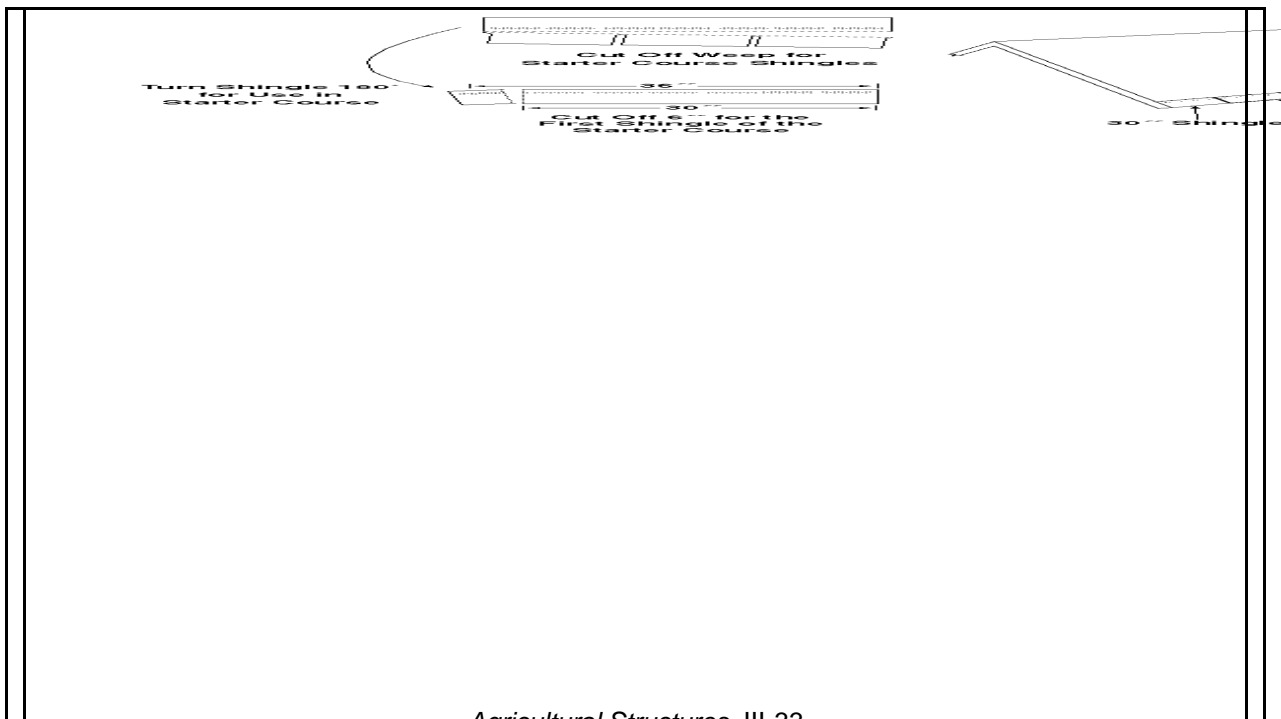

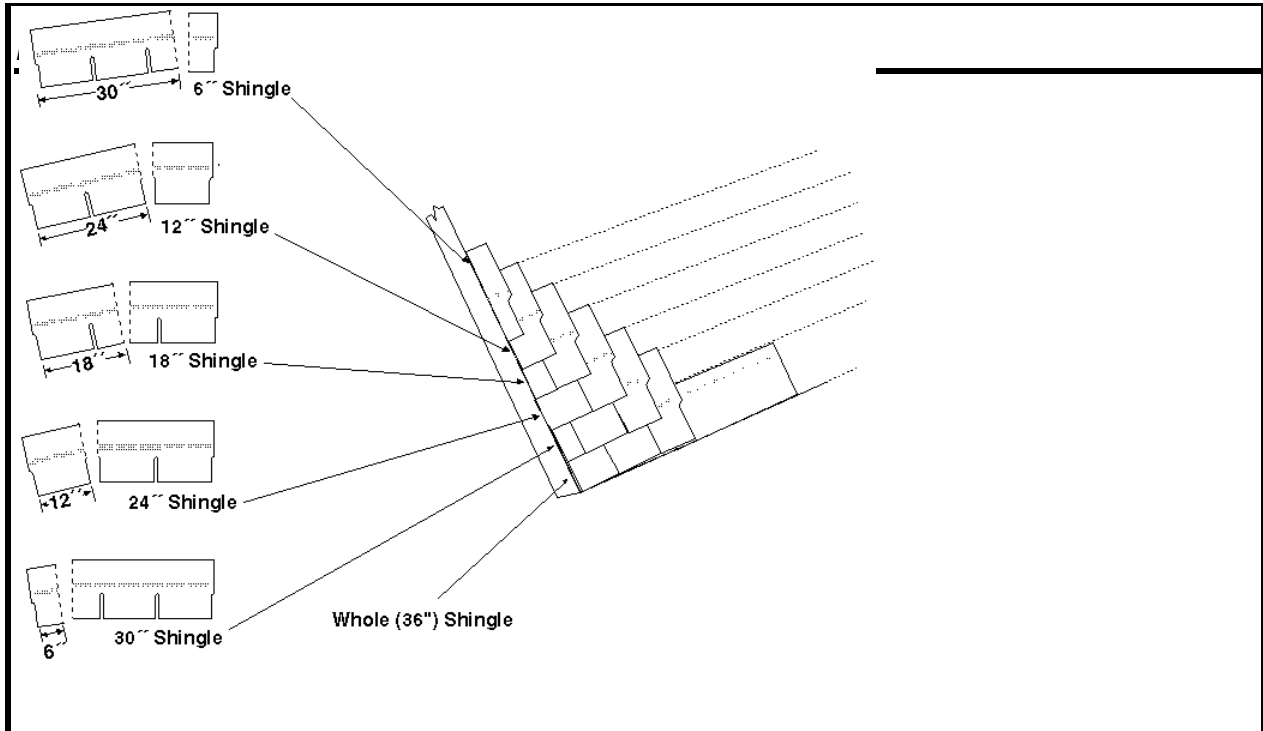

Two methods are used to finish the cap or final course covering the roof's peak. One method is to cut three-tab shingles into three sections and lay them across the peak overlapping the top courses on each side of the ridge. Figure 8.4 shows how to cut a full shingle for cap shingles and how each cap shingle should be trimmed prior to attaching it to the roof. Another method involves using special pre-made cap shingles on the peak.

Whichever method is used, these shingles must also overlap each other to prevent rain from getting under them. The direction of overlap Galvanized or painted metal roofing is most often installed with ring shank screws or nails. These fasteners come with a neoprene or lead washer attached. They are generally 2½ inches in length. When attaching the roofing materials, the ribbing running the length of the material is overlapped. The nails or screws are then placed through the ridges of the roofing material, not in the flat areas. The placement of fasteners will vary depending on the type of ribbing; the manufacturer's recommendations, which are usually printed on labels for the roofing, should always be followed. The fasteners are generally used at rate of 1½ pounds or 100 fasteners per square. When working with metals, aluminum and galvanized metal materials should not be used together. This combination will result in an electrolyte reaction that quickly causes corrosion.

depends on the normal wind direction. If the wind is commonly from the north, the shingles should start at the south end of the roof. This will leave exposed edges of the cap shingles facing south, where the wind and rain cannot get under them as easily.

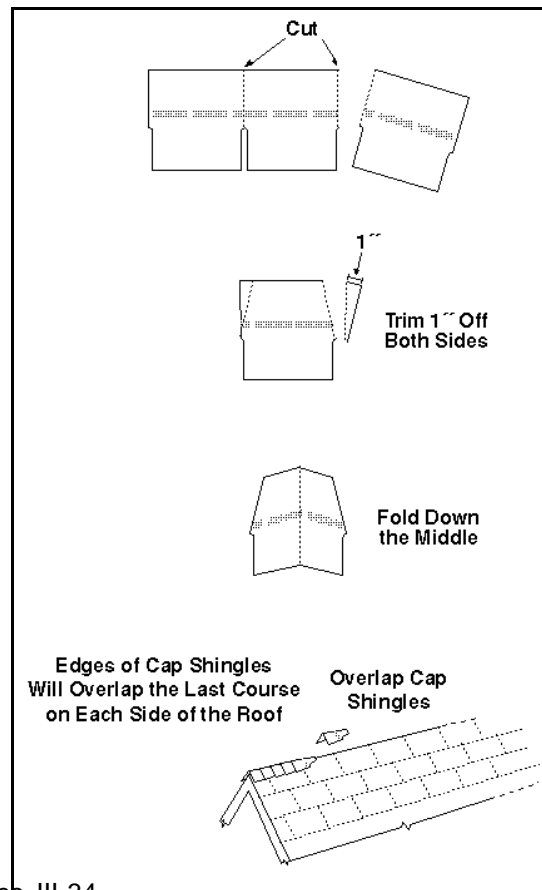

Lesson 8: Roofing Materials

Summary

Roofing materials for agriculture structures will generally be made of asphalt, fiberglass, or metal, and each material has its advantages and disadvantages. Roofing material is applied to either a solid decking surface or a purlin system that is attached to the top of the rafters or trusses. The material must be attached carefully using the proper technique to ensure that the roof is secure and watertight.

Credits

Ball, John E. *Tools, Steel Square, and Joinery*. Vol. 1 of *Carpenters and Builders Library*. Revised by John Leeke. New York: Macmillan, 1991.

Boyd, James S. *Practical Farm Buildings*. 3rd ed. Revised by Joshua L. Reynolds. Danville, Ill.: Interstate Publishers, Inc., 1993.

Lindley, James A., and James H. Whitaker. *Agricultural Buildings and Structures*. Rev. ed. St. Joseph, Mich.: American Society of Agricultural Engineers, 1996.

Lesson 9: Heating, Cooling, and Ventilation

Lesson 9: Heating, Cooling, and Ventilation

Heating, cooling, and ventilation needs in agricultural structures vary according to the uses of the structure. All structures are affected to some degree by these factors. However, for some structures, they must be carefully regulated for the structure to serve its intended purpose.

The Purpose of Insulation

Agricultural structures that serve to shelter anything that is sensitive to temperature must allow the environment of the structure to be regulated. Animals can only survive and function within a certain range of temperatures. Many chemicals must be kept at certain temperatures to remain usable and safe. Machinery is also affected by temperature and may be damaged or cease to function if not provided with appropriate shelter. Insulation is one way that structures are equipped to regulate temperatures. The materials used for insulation are varied in form and application, but they all enhance a structure's ability to regulate temperature. Insulation should slow down or stop the movement of air between the inside and outside of a building. A properly insulated building can dramatically reduce the cost of heating and cooling because the temperature of the building does not fluctuate much once the desired temperature is achieved.

Insulation works by reducing and restricting heat transfer. It inhibits conduction and convection transfers. Conduction refers to the transmission of heat through solid matter because of contact between hot and cold areas, while convection transfers occur as heat moves through a liquid or gas. Insulation can also protect against heat transfer from radiant heat, which is given off by sources of heat, such as the sun. Radiant transfers are inhibited by the use of foil on the side of the insulation that faces an air space.

A particular insulation's ability to resist the transfer of heat through the material is usually. Many different types of materials are used for insulation, which is available in a wide range of R-values and levels of fire resistance. Manufacturers create their own products by combining materials and treating them

expressed mathematically as an R-value. The higher the R-value is, the greater amount of insulation provided. As a general rule, a structure with insulation that has a high R-value requires less energy to maintain a desired temperature than a building with insulation with a lower R-value.

Types and Methods of Insulation

The insulation industry is progressive in the application of technology, and many different types of insulation are available for most applications. The choice of a particular type of insulation depends on factors such as cost, the suitability of the material for the application, and the adaptability of the insulating material to the structure. Cost is most often related to the insulation's R-value and the ease or efficiency with which the material may be installed. Usually, the higher the R-value, the more expensive a given material is. When considering the suitability of insulation for a particular application, one aspect that should be assessed is whether the insulation may come into contact with water from condensation or leaks, which can reduce its effectiveness. Water is detrimental to some forms of insulating material, while other materials may be water resistant but have a greater cost per unit of R-value. The structure's physical characteristics must also be considered when selecting insulation. For example, structures with solid walls of concrete or metal do not have a convenient space in which to place insulation.

When evaluating insulation, fire resistance and toxicity are also concerns. While some insulation is chemically treated to make it fire retardant, materials that are not fire resistant or that give off toxic fumes when exposed to flame should only be used in applications where they are covered with a suitable protective material, such as masonry. Also, some insulating materials may be irritating or toxic if physical contact occurs or they are ingested; these materials may be a problem in a structure that houses livestock.

chemically; specific information about a particular type of insulation must be obtained from the manufacturer or retailers. Some commonly used natural or organic insulators include cotton, cellulose, shredded bark,

Building Construction

shavings, sawdust, and straw. These insulators are made of natural materials and are generally cheaper. Manufactured materials used for insulation include fiberglass, rockwool, expanded mica, fiber board, cellular glass, expanded polystyrene, expanded polyurethane, urea formaldehyde, and polyisocyanurate. These insulators have a higher R-value per inch of thickness.

The methods by which insulation is applied vary.

For example, depending on the method used, insulation may be placed between framing members or applied to the outside of the structure in the form of sheathing. Common methods of insulation include blanket, batt, rigid, and fill insulation.

Blanket - Blanket insulation consists of wide rolls of material, often with foil covering on one or both sides and an insulating material like fiberglass in the middle. This method of insulation is often used for insulating metal buildings and covering large sections of walls. The insulation is usually stapled to the inside walls of the structure on wide, flat surfaces.

Batt - Batt insulation is provided in rolls of material in pre-cut sections, usually 4 to 8 feet in length and 16 inches wide with a thickness of 4 to 6 inches. However, the exact size of this material varies with the intended application. Batt insulation fits between the studs in the walls or other framework in structures and is fastened in place with staples.

Rigid - Rigid insulation is available in the form of sheathing, usually 4' x 8', in varying thicknesses.

It can be made of a number of materials but is most commonly Styrofoam. It is often covered with foil on one or both sides. Rigid insulation is usually nailed in place on the outside walls of a structure before siding is applied.

Fill - The material for fill insulation is in a loose form, possibly small beads or a form resembling snowflakes. This type of insulation is generally made of fiberglass or expanded mica. It may come in bags that are simply emptied where needed, as in the cores of masonry blocks. Fill insulation may also be mechanically blown in place through a large hose that feeds the material to the desired place. Sometimes this type of material is mixed with chemicals to make

it adhere to a horizontal or overhead surface and then blown into place.

The Importance of Ventilation

Ventilation is the movement of air through an area, either naturally, because of convection air currents, or mechanically. Poor ventilation can be unhealthy and dangerous. For example, methane gas, which can asphyxiate animals and may be explosive, is a by-product of decaying organic matter and can build up to hazardous levels in areas with inadequate ventilation. Fumes given off by some substances can be toxic if they accumulate in an enclosed space. Poorly ventilated buildings promote the growth and transmittal of disease-causing microorganisms because of increased temperatures and moisture levels within the structure. The ventilation of a structure will affect air temperature, moisture level, number of microorganisms, and concentrations of odor and gases. Proper ventilation can control temperature and moisture levels, thus reducing the growth of microorganisms. It can also diminish odor problems and prevent the accumulation of dangerous gases.

Windows and doors alone are often able to provide suitable ventilation and should be planned carefully since they can be a simple and economical way to ventilate a structure. Fans and blowers are also commonly used in agricultural structures to assist with ventilation. Mechanical ventilation can involve the use of elaborate systems with duct work and electronic thermostat switches to activate a fan or may be as simple as a window fan or roof-mounted turbine vent.

Ventilation is often effective at lowering temperatures. However, at times structures can become too hot even with ventilation. Animals may be unable to function well if a building is too hot; problems such as not breeding, weight loss, and terminated pregnancies may result. In these cases, mechanical cooling is necessary, although it may be costly. Water evaporative systems are sometimes used. These systems vaporize water, thus increasing the humidity while circulating the air and cooling the structure.

Another option is the use of refrigeration systems (air conditioners), an expensive but effective solution if designed and used properly. Before installing equipment to cool a structure,

Lesson 9: Heating, Cooling, and Ventilation

the system should be considered carefully, and professional advice should be sought in most cases to avoid complications. For example, animals that depend on respiration to cool

Supplemental heating is sometimes necessary in agricultural structures. Systems and designs vary, but as a rule, structures are heated using radiant, floor, or unit systems. Heat may also be produced by furnaces or boiler systems using air, water, or a combination of both as a transfer medium.

When radiant heating systems are used, radiant heat passes through the air until it comes into contact with an object, such as an animal, and passes on its energy as heat. It will not heat objects out of its path. Gas or electricity may be used to power these systems. An example is an infrared heater.

Floor systems are usually designed to heat specific areas, such as a nursery in a farrowing house. Hot water pipes or electric elements may be buried just below the surface of the floor. These systems may be powered by electricity, natural gas, or ground-source heat pumps, in which the ground heats the water.

Unit heaters are used to heat the air in a general area of a structure. These heaters often use fans to circulate the air after heating it. They may be powered by a variety of fuels, such as propane, natural gas, or electricity. Unit heaters are similar to the heaters found in large gymnasiums, shops, or stores, with a heating unit mounted overhead and a fan blowing the heated air from the heater.

Boilers and furnaces are large commercial appliances utilizing a system of pipes, ducts, or vents to transfer heat to where it is needed. Boilers heat hot water that is pumped to radiators, while furnaces heat air and blow it through ductwork to the rest of the building. They may be powered by fuels such as propane, natural gas, electricity, or wood.

One important term to understand when dealing with heating is BTU. BTU stands for British thermal unit; one BTU is equal to the amount of heat required to raise the temperature of 1 pound of water 1 degree Fahrenheit. This term is used when describing a system's heating ability.

themselves can be adversely affected by temperature and humidity changes.

Types of Heating Systems

Consulting with a heating professional is recommended when planning a large system. Safety concerns, such as the proper delivery of the fuel or power, ventilation for by-products like carbon monoxide, and potential fire hazards, makes the installation of heating systems a critical area of construction. The amount of heat needed as well as the cost of installation and operation are questions that must be answered accurately for the overall heating system to be suitable for the structure.

Feasibility of Solar Heating

The solar energy reaching the earth is estimated at 100,000 times the total of all the energy output from all existing power stations. However, this type of energy is not always easy to utilize effectively. Fortunately for all life on earth, this energy is quite diffuse by the time it reaches earth. Solar energy is also not consistent on a daily basis. These factors, as well as the cost of systems for collecting solar energy, have made solar heating a possibility but not often a first choice. At times when fossil fuel prices have risen sharply, as in the 1970s, a great deal of research into the applications of solar technology in the agricultural industry has taken place. However, as prices stabilized, research turned more toward efficient uses of fossil fuels since they provide very controlled and predictable energy amounts.

Passive solar heating is feasible if a building has a consistent solar exposure not obstructed by trees, other buildings, clouds, or other items that block the sun's rays. This type of heating makes greenhouses effective, as greenhouses utilize passive solar heat to maintain temperatures.

Passive solar energy can be used to help heat structures fairly simply. Orienting structures and windows to take advantage of solar energy is sometimes advantageous. Positioning a structure so that its south wall has windows and an unrestricted plane with no trees, buildings, or other obstacles will allow solar energy to enter the structure naturally. Covering the windows with an insulating material at sundown will help

Building Construction

the structure to retain the heat. Strategically placing large water containers, such as 55-gallon barrels, or building with stone or masonry where they can be warmed by the sun will also help heat the structure. They act as storage units. Insulation reduces heat transfer through a building. Many different types of insulating material are available, and each type should be evaluated by considering the structure's needs and the costs, hazards, and benefits of the insulation. Ventilation should also be carefully evaluated since it can affect the safety of a structure. Another factor that should be considered when constructing a building is whether a heating system is needed, and if so, what type of system is appropriate. Systems for heating buildings (and cooling them, if necessary) can be customized to meet most needs. Structures can also be designed to make use of passive solar heating.

Credits

Boyd, James S. *Practical Farm Buildings*. 3rd ed. Revised by Joshua L. Reynolds. Danville, Ill.: Interstate Publishers, Inc., 1993.

that collect and hold the sun's heat, releasing it back into the structure over a period of time.

Summary

Lindley, James A, and James H. Whitaker. *Agricultural Buildings and Structures*. Rev. ed. St. Joseph, Mich.: American Society of Agricultural Engineers, 1996.

Time-Life Editors. *Insulating & Weatherproofing*. Alexandria, Va.: Time-Life Books, 1996.

Lesson 1: Safety in Working with Concrete

Lesson 1: Safety in Working with Concrete

Concrete is involved in nearly every type of construction project. Its benefits for construction ensure that it will continue to be popular in the future. Concrete does have a few specific hazards that are described in this lesson, but the potential for injury can be greatly minimized by following the suggestions given here.

What is Concrete?

Concrete is an artificial stone-like material consisting chiefly of sand, gravel, cement, and water. These materials are mixed together and harden and set due to a process called hydration, in which the cement combines with water and bonds to the different components. Concrete is a versatile construction material that can be adapted to almost any application and molded into many different shapes. It has a relatively low maintenance cost, is easily repaired and poured, and is easy to work. Figure 1.1 shows a list of some of the diverse uses of concrete.

Figure 1.1 - Uses of Concrete

Sidewalks	Roads	Brake linings
Foundations	Dams	Fence posts
Floors	Sewer pipes	Barges
Walls	Monuments	Canoes
Chimneys	Bridges	Caskets
Beams	Canals	Missile silos
Bricks	Bank vaults	Nuclear containment facilities

Dangers in Working with Concrete

A hazard encountered in concrete construction is tripping and falling. When preparing a site for concrete to be poured, rebar or wire is commonly staked and tied with wire at the site, creating a maze of wire and metal. Crossing this material only when necessary and taking care when doing so is the best way to avoid falling.

Working with concrete may involve different kinds of equipment that are potentially dangerous to other people. Tools such as power floats, which are gasoline-powered machines used to put a smooth surface on concrete, or mobile concrete shoots on trucks can kill a person if he or she is accidentally hit. Being alert at all times can help avoid accidents with equipment.

Burns caused by the chemicals in concrete are perhaps the most common injury when working with wet concrete. Concrete burns, which may involve large areas of the body, can be very severe; they consist of ulcerated areas where skin and flesh have been eroded away. These burns are extremely painful and require medical attention. The burns are caused by prolonged skin contact with some of the ingredients used to make cement. The amount of time before serious damage occurs will vary depending on the individual and situation. However, exposure of one hour or more will usually cause significant skin damage, and the length of time could be much less for someone with sensitive skin. By the time significant discomfort is felt, the skin has already been damaged, which often leads people to become careless since they do not realize they are injured until it is severe. Protective clothing and gear should always be used to prevent injury. Immediately flushing with water and washing an exposed area will likely prevent any effects.

If concrete is mixed on site, the cement in powder form has the same potential for injury as when it is mixed. Powdered cement may become airborne. This powder can be extremely irritating and damaging if it gets in the eyes or is inhaled, producing the same caustic results as exposure to wet cement. The use of proper protective gear minimizes this hazard.

Protective Clothing

The following items of clothing are of value in preventing injury. Workers should use protective eye gear, either goggles, which provide the best protection, or safety glasses, when working with cement in wet or powdered form. Disposable face masks are inexpensive and effective in reducing the amount inhaled when working with powdered cement. A long-sleeved shirt and heavy work pants will greatly reduce the amount of skin exposed.

Concrete

Waterproof or heavy work gloves will protect the hands from exposure; waterproof gloves are

preferable. Finally, rubber boots will help protect the feet from exposure.

Summary

Agricultural structures usually involve concrete. Being aware of the hazards involved and following the safety suggestions given in this lesson will greatly reduce the risk involved. Protective clothing is particularly important in preventing injury.

Lindley, James A., and James H. Whitaker. *Agricultural Buildings and Structures*. Rev. ed. St. Joseph, Mich.: American Society of Agricultural Engineers, 1996.

Ahrens, Donald L. *Concrete and Masonry Construction*. St. Paul, Minn.: Hobar Publications, 1976.

Credits

Huth, Mark W. *Construction Technology*. 2nd ed. Albany, N.Y.: Delmar Publishers, Inc., 1989.

Lesson 2: Factors Affecting the Quality of Fresh Concrete

Lesson 2: Factors Affecting the Quality of Fresh Concrete

Concrete has many uses in the agricultural industry, from sidewalks to buildings. When looking at concrete, the question arises, "How is concrete made?" This lesson will explore the raw materials used in concrete, how to mix concrete, the additives used in concrete, and how to test concrete to see if it has the proper consistency.

The Components of Concrete

Concrete is a compound made from several different components. The main materials in concrete are aggregates, water, and cement.

Aggregates (sand and gravel) - Aggregates typically make up 60 to 80 percent of the volume of the concrete mixture. Aggregates are classified into two main categories. Fine aggregates are those particles that are smaller than a quarter inch in size; they can pass through a number four sieve, which is a sieve with four wires per inch. Fine aggregates are typically called sand. Coarse aggregates, called gravel, are particles larger than one quarter inch in size. The sand used in concrete should be clean and relatively dry, while the gravel should be clean and uniform in size. A larger aggregate size will result in stronger concrete and more economical costs.

Aggregates have several functions. They provide a cheap filler material that adds volume to the concrete. They are also stable materials that will resist forces on the concrete and that help to maintain volume while the concrete sets and hardens.

Occasionally other compounds besides sand and gravel are used as aggregates for speciality applications. Sometimes vermiculite and perlite, compounds naturally found in the soil, are utilized when the concrete needs to be lightweight. The resulting concrete can be sawed. Clay, shale, and crushed brick can act as insulation. Steel and iron shot may be used as aggregates in the high density concrete for radiation shielding, as in a nuclear reactor or in the walls surrounding the x-ray laboratory in a hospital or clinic.

Water - Water is another important ingredient in concrete. Water serves several purposes in the concrete mixture. It allows the concrete to be molded or shaped, aids in mixing, and plays an important role in hydration, the chemical reaction between water and cement that bonds the mixture together.

The water used in concrete should be clean. If the water has too many impurities, the quality of the concrete will suffer. Generally, if the water is potable, or drinkable, it can be used in the concrete. The water should have less than 2,000 ppm (parts per million) of total dissolved solids.

Abram's Law is an accepted rule for concrete that describes the relationship between water and concrete. As stated in Ahren's *Concrete and Concrete Masonry*, the law is "For given materials and conditions of handling, the strength of concrete is determined primarily by the ratio of the weight of mixing water to the weight of cement as long as the mixture is plastic and workable." In other words, less water is generally better in mixing concrete, as long as the mixture is workable. Too much water weakens the final concrete mixture.

Cement - Cement and concrete are often referred to as if they are the same thing, but they are not. Cement is an important ingredient in concrete. With water, it forms the glue that holds the concrete together as it forms and hardens.

Portland cement is probably the most common cement used today. Portland cement was first patented in 1824 by a man named Joseph Aspdin.

The manufacturing of portland cement involves several steps. Limestone is the base material for cement. The limestone is taken from a quarry and crushed into a fine powder. This powdered limestone is then mixed with clay or shale, and the mixture is ground again. The ground mixture is sent to a kiln, or oven, to dry. The name of this dried product is clinker. After the clinker is removed and cooled, gypsum is added, and the mixture is ground one final time to produce portland cement. Table 2.1 gives the final chemical composition of portland cement.

Concrete

Five types of portland cement are commonly produced and used for different applications. Type I is for common applications. Type II is used where heat buildup is a concern, as in a driveway or walkway for a building. Type IV, or low heat cement, reduces the heat generated by hydration; it is used in confined indoor spaces. Type V, also known as sulfate resistant cement, is necessary when the concrete is poured over alkaline soils, which can decrease the durability of the concrete.

Table 2.1 - Cement Composition

Material	Percentage (%)
Lime	60-66
Silica	19-25
Alumina	3-8
Iron	1-5
Magnesia	0-5
Sulfur trioxide	1-3

Two agencies regulate portland cement and its specifications. They are the American Society for Testing and Materials (ASTM) and the Canadian Standards Association (CSA). These agencies determine the requirements for the different categories of portland cement and work to maintain concrete quality.

Two agencies regulate portland cement and its specifications. They are the American Society for Testing and Materials (ASTM) and the Canadian Standards Association (CSA). These agencies determine the requirements for the different categories of portland cement and work to maintain concrete quality.

Mixing Concrete

The most common agricultural mixes are usually described in one of three different ways. These descriptions are useful in ordering and preparing the mixture. The first method of describing concrete mixtures refers to the number of bags of cement in each cubic yard of concrete, which is equal to 27 cubic feet of volume. Ready-mix concrete ordered through a supplier is usually

thick wall or large structure. Type III, or high early strength cement, is useful when the concrete needs strength in the first two to three days after pouring, ordered using this method. The three most common ready mixes and their applications are shown in Table 2.2.

A second method of referring to concrete mixes uses a ratio that shows the relative amounts of the different components of the concrete. A common mixture is 1:2:3-6. This ratio indicates that the concrete is one part cement, two parts sand, three parts gravel, and six parts water. Each part consists of a particular volume, such as one cubic foot.

The third method used to describe concrete mixes indicates the gallons of water mixed with each sack of cement. Common mixes described in this manner are 5.0, 6.0, and 7.0. In their uses, these mixes correspond to the various ready mixes already discussed, as indicated in Table 2.2. To learn the amounts of other components needed to make the cement, specific charts must be consulted to find the volume of each ingredient in a cubic yard. These charts may be available in reference books about concrete.

Concrete Additives

Sometimes circumstances may call for a particular type of concrete. For that reason, certain additives, called admixtures, are mixed into the concrete to give it special characteristics.

Concrete additives fall into six main categories: air entraining additives, superplasticizers, retarding additives, accelerating additives, mineral additives, fibers, and pigments.

Air entraining - Air entraining additives force small air pockets in the concrete. The process of trapping air in the concrete is called air entraining. Large air pockets can weaken the

Table 2.2 - Common Mixes

Mix	Applications
5 bags of cement/yard, or 7 gallons of water/sack of cement	Foundation walls, footings
6 bags of cement/yard, or 6 gallons of water/sack of cement	House floors, dairy floors, driveways, septic tanks
7 bags of cement/yard, or 5 gallons of water/sack of cement	Concrete under severe conditions, concrete exposed to acids or severe weather

Lesson 2: Factors Affecting the Quality of Fresh Concrete

concrete, but small pockets are beneficial in several ways. Air entraining improves concrete's workability, water tightness, and finish qualities. It also increases the concrete's resistance to freezing and thawing and its Superplasticizers - These additives increase the strength of the concrete by altering it so that it needs less water to be workable.

Retarding - Retarding additives slow down the setting process, resulting in greater long-term strength.

Accelerating - This type of additive speeds up the setting of the concrete, resulting in more early strength and making the concrete less vulnerable to temperature changes during setting. They are frequently used in cold weather to force the concrete to set more quickly. One of the more common additives used today is an accelerating additive, calcium chloride.

Mineral - Mineral additives increase the strength of the concrete.

Fibers - Fibers reduce the tendency of the concrete to break along seams or at the edges. The fibers do not truly increase the strength of the concrete but help to bind the concrete together.

Pigments - Pigments change the color of the concrete. Adding certain minerals to the whole batch of concrete or only to the final layer can change the color of the concrete. Table 2.3 lists the minerals added to concrete to produce various colors.

Table 2.3 - Concrete Pigment Additives

Color	Additive
Blue	Cobalt oxide
Brown	Brown iron oxide
Buff	Synthetic iron oxide
Green	Chromium oxide
Red	Red iron oxide
Gray	Black iron oxide or carbon black

resistance to salt and sulfates, which can erode the concrete. Concrete with these small air pockets is called air-entrained concrete.

Other than calcium chloride, most additives are not commonly sold in hardware stores but are carried by local ready-mix suppliers. They can be mixed into the concrete to meet the specific needs of the project.

Slump Tests

Mixing concrete is not like cooking from a recipe, because some ingredients may already contain a certain moisture content. In mixing concrete, adding the right amount of water is important. The amount added to the mix should be decreased if the aggregates are already moist, or the concrete will be too wet. A slump test determines if the concrete is of the proper consistency; it indicates if more or less moisture is needed. The slump test is important because the test makes it possible to prepare a concrete mixture with the optimal combination of strength and workability. This test is the final step prior to pouring the concrete.

The procedure for performing the slump test is relatively simple. The test involves the use of a metal cone that is 12 inches tall, with a diameter of 4 inches at the top and 8 inches at the bottom, and open at both ends. It is placed on a flat surface with the wide end down. Prior to being filled with concrete, the cone may be moistened with oil to make cleanup easier. The cone is first filled one-third full with concrete. The concrete is tamped down with a 12-inch metal rod 25-five times to make it settle and remove any air pockets. Concrete is then added until the cone is two-thirds full, and the concrete is tamped again. Finally, the cone is filled, and the concrete is tamped for the third time. The cone is then carefully removed, and the concrete "slumps," or drops in height due to gravity.

After the concrete has stopped decreasing in height, the slump is measured. A straight edge is placed across the top of the cone, and a measurement is taken from the straight edge down to the average level of the top of the concrete, as shown in Figure 2.1. Usually, the slump should be between 1 and 3 inches. Too much slump indicates too much water, while not enough slump indicates a lack of water. If too

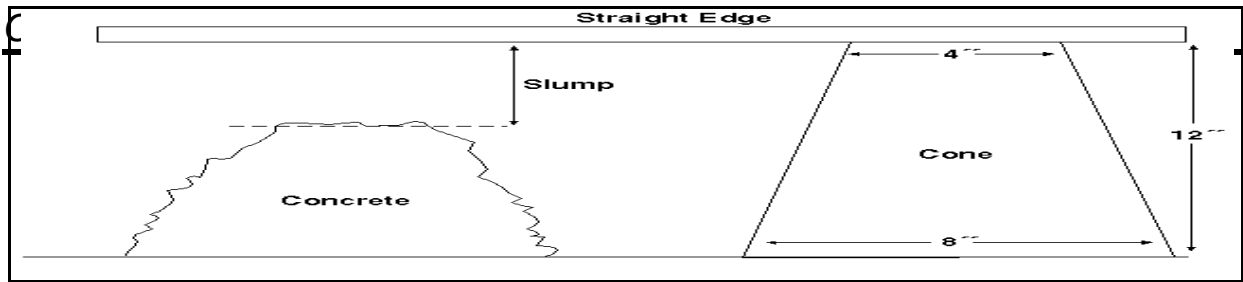

much water is present, adding aggregates or cement will thicken the mixture.

Adding ingredients should be the last resort in mixing concrete because it will result in weaker concrete. Ideally, the correct amounts of

Summary

Concrete is a mixture of cement, aggregates (sand and gravel), and water. The relative amounts of these ingredients in the mixture depend upon the use of the concrete. Concrete mixes are described in terms of the bags of cement per yard; the ratio of cement, sand, gravel, and water; and the gallons of water per sack of cement. The seven classes of common concrete additives are air entraining additives, superplasticizers, retarding additives, accelerating additives, mineral mixtures, fibers, and pigments. A slump test is necessary to determine the proper amount of water for the concrete mixture.

Credits

Ahrens, Donald L. *Concrete and Concrete Masonry*. St. Paul, Minn.: Hobar Publications, 1976.

ingredients are used the first time. Also, most state or federal construction contracts prohibit adding ingredients after the initial mix. If the mix is not correct when it reaches the work site, the entire batch is rejected.

Boyd, James S., and Carl L. Reynolds. *Practical Farm Buildings*. 3rd. ed. Danville, Ill.: Interstate Publishers, 1993.

Cooper, Elmer L. *Agricultural Mechanics: Fundamentals and Applications*. Albany, N.Y.: Delmar Publishers, 1997.

Lindley, James A., and James H. Whitaker. *Agricultural Buildings and Structures*. Rev. ed. St. Joseph, Mich.: American Society of Agricultural Engineers, 1996.

Materials Science and Technology (MAST) Teacher's Workshop. "Concrete." Produced by the Department of Materials Science and Engineering at the University of Illinois, Urbana/Champaign. <http://mach-pc66.mse.uiuc.edu/~tw/concrete/concrete.html> (29 Aug. 1998).

Lesson 3: Site Preparation

In any situation where a building is being constructed, the building site needs to be prepared to make future steps of construction more efficient. A number of factors affect the final quality of a building site. The process of site preparation addresses these factors.

Preparing a Subgrade

Once a site has been selected, it needs to be prepared for construction. This process begins with preparing the subgrade, which is a surface leveled off in preparation for laying a foundation.

The subgrade will be slightly bigger than the foundation. The steps in forming a subgrade are important for the rest of the construction process and so should be followed closely.

Drainage - If the construction site does not drain well, installing a drainage system below the site to remove excess water may be necessary. If the system is needed, installation is much easier before any construction occurs. A drainage system typically consists of a series of underground pipes that collect excess water and direct it away from the site. Systems are usually installed by a licensed business on a contract basis.

Removal of topsoil - In some cases, the topsoil is scraped off the site with a tractor and blade prior to other excavation. The topsoil may be saved for later use, especially for landscaping the property. If the topsoil is not used for landscaping, it can be sold, since many people buy good quality topsoil for use around their homes.

Removal of organic material - Organic material consists of matter produced by plants and animals that is found in or on the soil. The organic material on the building site needs to be removed as much as possible. This material does not readily mix with concrete and can even have a slightly oily surface, which further prevents mixing. The particles in the concrete cause inclusions, or holes created when the matter eventually decays, that will weaken the overall strength of the concrete. Also, organic material will keep the ground from being packed tightly to support the weight of the structure, and

as the material decays, settling will occur. Organic material is typically removed with a tractor and blade.

Removal of rocks and stones - In addition to topsoil and organic material, larger rocks and stones should be removed, since they may cause major differences in the slope of the land. They can be removed using a tractor and blade. These rocks can be placed in lower areas, as well as areas with poor drainage.

Subgrade slope - After the removal of topsoil, organic material, rocks, stones, and trash, the site should be graded using a tractor and blade to create a desired slope for drainage purposes. Typically, a 3 percent slope away from the building is considered minimal.

Packing or compacting - Once the site has the proper slope, the soil needs to be packed. Driving a tractor back and forth across the site so that the tires form a pattern across the previous tire tracks will pack the soil down. Portable, hand-operated packers are also available. Packing is commonly done using a sheep foot roller to compact the soil. Packing prevents differential settling of the soil, in which some areas settle more than others because of soil compaction due to the weight of the concrete.

Sand or aggregate fill - Most construction sites use fill, which consists of added sand or aggregates, to create a level site and leave a more uniform surface under the concrete foundation. If the soil texture and structure (the shape of the particles the soil normally forms) do not permit proper soil drainage, placing 4 to 6 inches of sand or aggregate on the site will enhance drainage by allowing water to flow downward more readily. If fill is added, the site should be packed again after the fill is in place.

Vapor barrier and insulation - If a drainage system cannot be used or if excessive soil moisture is a continual problem, a vapor barrier or retarder should be used under the concrete. The vapor barrier, which is typically polyethylene sheeting, prevents moisture from being absorbed into the concrete. In cold climates, insulation is also commonly placed under the concrete to maintain heat in the building and keep the floor warmer.

Concrete

Dampening the site - If a vapor barrier is not used and the ground is dry, the site should be sprayed with water to dampen the fill. This practice will prevent excessively dry fill from pulling water out of the concrete during the curing process. If the ground is relatively moist already, dampening the site is not necessary.

Footings

Once the subgrade is prepared, construction of the building can begin. The first step in constructing a building is to construct the lowest part of the building, the footings. Footings, as shown in Figure 3.1, are large supporting blocks of concrete between the foundation and the soil.

They are normally placed around the exterior edge of the building and under walls that will support the structure's weight. The footings spread the weight of the building across a larger area and make the structure more stable. Footings are usually poured on site but can be poured at another location and later placed at the site. They are necessary for several different reasons, including temperature, moisture, and soil structure, all of which can affect the foundation of the building.

The frost line is the deepest point in the soil where frost is normally found during the winter. Footings located below the frost line will decrease, if not eliminate, movement of the building due to expansion and contraction of the soil because of temperature changes. To place the footings below the frost line, the building site must be excavated to the proper depth.

Variable levels of moisture during the year will cause the soil to expand and contract as well. The building can be stabilized by placing large footings on a sand or aggregate base.

Soil structure can affect the use of footings. Soils with a very loose soil structure tend to allow more settling of the building over time. This settling can be diminished by integrating larger than normal footings. Also, certain clay soils expand and contract dramatically when wet. Placing footings on a layer of sand and aggregate can reduce the movement of the building due to these changes.

Laying Out the Building

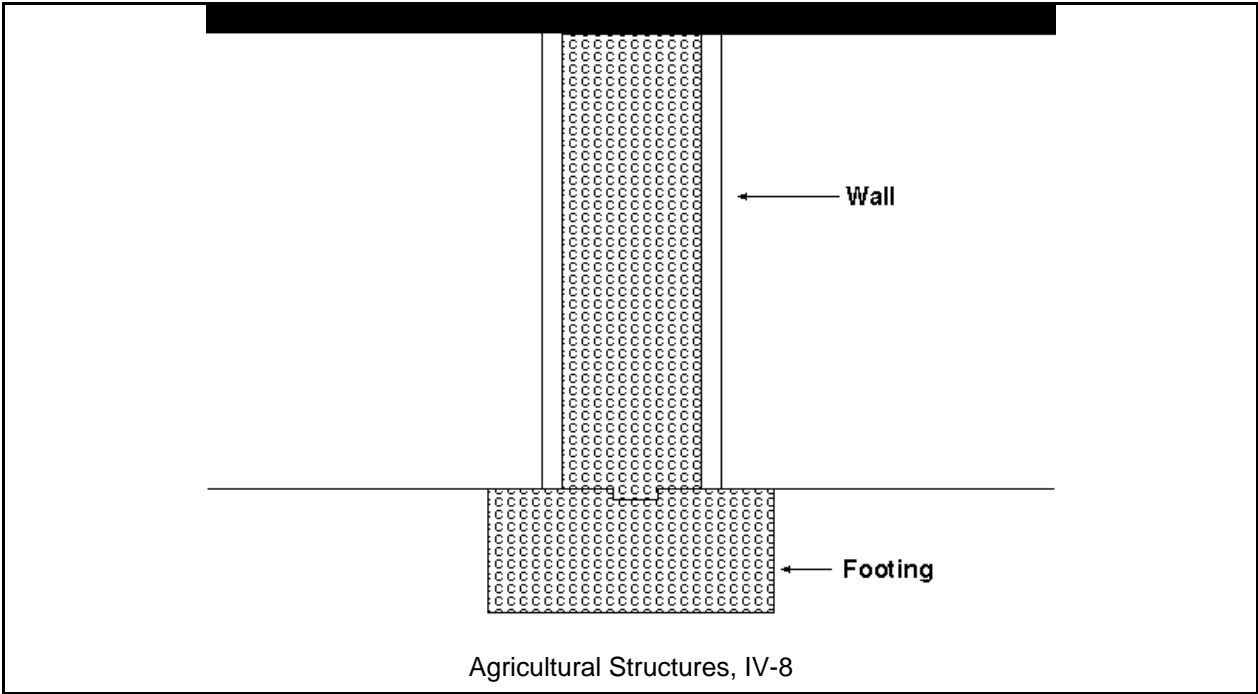

Footings need to be placed carefully, since they will determine whether the building is placed squarely in the correct location. The first step in laying out a building is driving stakes into the ground where the corners of the structure are to be located. If an addition to an existing building is planned, the two corner stakes should be placed in relation to the building by measuring the desired distance from the building and the distance between the stakes. For a new structure, a stake is driven to mark the location of a corner, and measurements are made to the adjacent corners. After stakes are placed at these corners, measurements can be made from them to determine the placement of the final stake. The measurements between the stakes should be made carefully so the building is exactly the size desired. After all the corner stakes are in place, strong twine or rope is tied between them to represent the sides of the building.

To determine if the stakes are square on all four corners of the building, diagonal measurements should be made from the corner stakes. When the measurements are identical, the building is square, as illustrated in Figure 3.2. If the building's diagonals are not equal, the stakes must be carefully moved. For example, if diagonal A was longer than diagonal B, as in the second diagram in Figure 3.2, stakes 1 and 2 would be moved to the left until the diagonal measurements are identical. Because of the twine connecting the stakes, the building's dimensions remain correct.

The corner stakes are where the forms will be placed for pouring the footings, so a method is needed to indicate the corners when the stakes are removed. The procedure for marking the corners involves the use of batter boards, which are shown in Figure 3.3. Batter boards are typically either 1" x 4" or 1" x 6" boards nailed to three 2" x 4" stakes at least four feet from the corner of the building. If the twine connecting the stakes is extended to the batter boards, the corner stakes can be removed because the intersection of the strings still marks the location of the corner of the building. Suspending a weight like a plumb bob from where the strings intersect at the corners will ensure that the strings cross exactly at the corner of the building.

After the lines are in place, the position of the lines is marked, and a saw kerf about 1/4" deep is

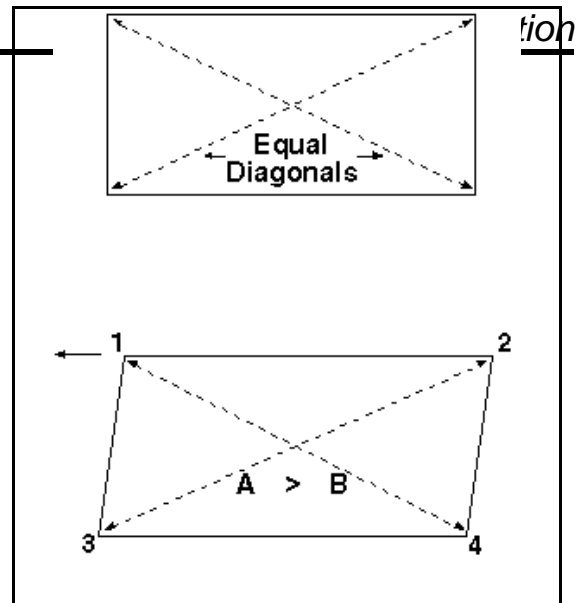

placement. The lines can then be removed and

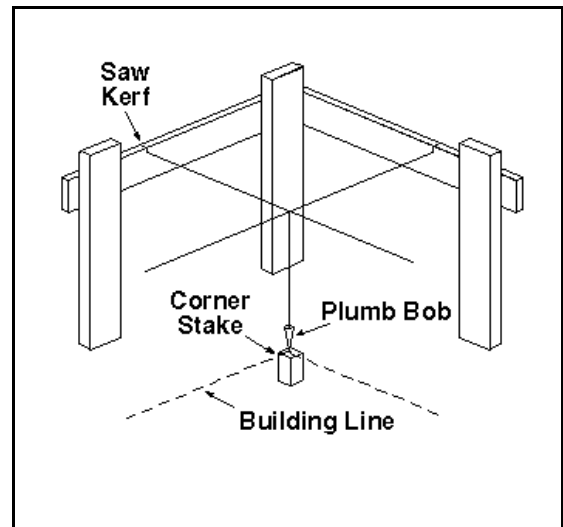

replaced if necessary. When the position of the lines is marked, the stakes can be safely removed. Forms, which will be discussed in greater detail in the next lesson, can then be placed under the string in preparation for pouring the footings.

Preparing the Final Grade

After the footings have been placed and soil is added around them to create a level surface, the final preparation of the site can be done. Preparing the final grade is the last step prior to pouring the concrete. For the final grade, more care should be given to the slope and fill on the site.

Concrete

The final slope of the building site can greatly influence the amount of concrete needed and the degree to which the forms that will hold the concrete will need to be leveled. To determine the slope of the building site, several different methods can be used. A hand-held level can offer reasonably accurate readings for the site. Once the exact location of the building has been determined, fill needs to be added across the site to maintain the desired slope. Fill is especially important if major depressions or high spots are found on the building site. Hopefully the initial work with a tractor and blade has made the location nearly level, but often fill is needed to make the entire site level. Low wet spots can be filled with aggregate or rocks.

Equipment Needed

The tools used in site preparation are not specialized. However, they make site preparation easier and more accurate. The tools needed to prepare a building site include a tractor with a blade, a compactor or packer for the soil, shovels, and a transit or level with a surveying rod and the tripod for the transit or level.

Summary

Site preparation is a very important step in building construction. The subgrade and final grade should be prepared properly to provide a good base for the foundation. Footings should be planned to support the structure, which needs to be laid out carefully to make sure that it is square. Proper site preparation will make the

To increase accuracy, a tripod-mounted transit or level should be used. This tool will provide much more accurate readings indicating the amount of soil to be removed, or cut, or the amount of fill added to various locations on the site.

rest of the steps in building construction easier to accomplish and result in a higher quality finished product.

Credits

Ahrens, Donald L. *Concrete and Concrete Masonry*. St. Paul, Minn.: Hobar Publications, 1976.

Boyd, James S., and Carl L. Reynolds. *Practical Farm Buildings*. 3rd. ed. Danville, Ill.: Interstate Publishers, 1993.

Cooper, Elmer L. *Agricultural Mechanics: Fundamentals and Applications*. Albany, N.Y.: Delmar Publishers, 1997.

Lindley, James A., and James H. Whitaker. *Agricultural Buildings and Structures*. Rev. ed. St. Joseph, Mich.: American Society of Agricultural Engineers, 1996.

Materials Science and Technology (MAST) Teacher's Workshop. "Concrete." Produced by the Department of Materials Science and Engineering at the University of Illinois, Urbana/Champaign. <http://mach-pc66.mse.uiuc.edu/~tw/concrete/concrete.html> (29 Aug. 1998).

Lesson 4: *Pouring a Concrete Slab*

One of the most common activities in pouring concrete is pouring a concrete slab. Concrete slabs are used in foundations, garage floors, sidewalks, and many other places. This lesson will examine the procedures used in pouring concrete slabs.

Tools for Pouring Concrete

As with any construction task, specific tools and equipment are needed to pour a concrete slab. The tools required include sledge and claw hammers, a carpenter's level, a shovel, a hose and water source to moisten the site, a tape measure, a transit or a surveyor's level used with a surveying tripod and surveyor's rod, a calculator for any calculations that may need to be made, a circular saw, a carpenter's or framing square, and lumber and 16d duplex-head nails for the forms.

Forms

Once this equipment has been obtained, construction can begin on the forms for pouring the concrete. Forms are structures designed to hold the concrete in the proper shape and location until it sets and hardens. Forms can be constructed of different materials, such as wood, aluminum or metal alloys, and earth.

Wood forms for pouring a sidewalk or slab are usually made of 2" × 4" or 2" × 6" boards. The wood should be free of knots and decay, which will weaken the form. Wood forms are usually coated with a lightweight oil to prevent the concrete from sticking to the form. If plywood is used, SP plywood, or plyform, should be utilized; it is a special plywood made with a waterproof glue that repels the moisture in the concrete so the concrete will not be dried out by the forms. Hardboard, a wood composite sometimes called Masonite, is sometimes used when forming curves because of its strength and flexibility. Wood forms are easy to construct and are relatively inexpensive.

Aluminum or metal alloy forms will give a smoother, more uniform finish to the concrete. These forms are structurally stronger than wood forms. They will yield extremely straight,

square concrete, since the forms do not bend or sway under the weight of the concrete like wood forms will. Aluminum or metal alloy forms are expensive to purchase and cannot be easily constructed like wood forms.

Earthen forms can be constructed by shoveling soil in a pile in the desired location. The earth is covered with a plastic lining to prevent soil from mixing with the concrete and to keep moisture from bleeding out of the concrete into the soil. Earthen forms are rarely used and result in a poor quality slab.

Constructing Forms

Once a type of form has been chosen, forms can be purchased or made. This section of the lesson will describe the construction of wood forms because they are the most commonly used type.

The first step in constructing forms is determining the desired height of the forms. For a 4-inch slab, which is a common size, 2" × 4" boards are used. However, if the board has been planed or smoothed, the end product is only 1½" × 3½". This board size can be used for forming a 4-inch slab if soil has been placed on the outside of the form to strengthen it and close the opening at the bottom. If thicker slabs are desirable, wider boards, such as 6-inch or 8-inch boards, are required for the sides of the forms.

The edges of the boards are put in place directly underneath the string or twine used when laying out the corners of the slab, as described in the last lesson. Small stakes should be driven at least 6 inches into the ground with a hammer every 4 feet along the outside of the boards to stabilize them and hold them in place. The tops of the stakes must be below the edge of the form to allow the slab to be worked as the concrete dries. If the stakes are above the edge, they will interfere with leveling the concrete. If necessary, the tops of the stakes can be cut level with the form using a circular saw. The stakes are nailed to the boards using duplex-head nails attached on the outside of the forms. This type of nail makes the removal of the nails easier when the forms are taken apart after the concrete sets.

Concrete

Once the outside edges of the forms are in place, the forms should be checked to ensure that they are square. A tape measure can be used to check whether the diagonals are equal. If they are square, a carpenter's level or the transit with its tripod and surveyor's rod should be used to determine if the forms are level. If they are not level, a hammer can be used on the higher spots of the form to decrease its height. At this point, whether the slab should slope or be level should be considered. If water or manure drainage is a concern, the slab should have at least a 4 percent slope in the direction that the excess water or manure should run off. This slope should be figured into the final placement of the forms.

If the slab is to curve, plywood can be used in place of boards to make the forms. The plywood should be cut so the grain of the plywood runs vertically because the stress from the concrete would crack or break the form if the grain ran horizontally. The stakes should be placed only 1 to 2 feet apart on curves instead of every 4 feet. Curves place more stress on the form, and more stakes are necessary to keep the forms in place.

Forms should be secured tightly at the corners to prevent them from separating. Sometimes corners are attached using bolts or screws, which are stronger than nails.

The Purposes of Reinforcement in Concrete

Concrete must often be reinforced to make it stronger and prevent various types of damage. Reinforcement can strengthen the concrete and help it to resist the forces acting on it. Concrete by nature has great compressive strength, which is the strength to resist forces pressing downward on the concrete. However, concrete does not have good tensile strength, which is the ability to withstand tension or pull. For example, a heavy weight, like a tractor, close to the edge of a slab might cause the concrete to crack or break because of the tension on the concrete at the edge. Reinforcing the concrete will increase its tensile strength, especially at the edge of the slab. Reinforcement will also reduce the tendency of the concrete to crack due to changes in temperature.

Types of Reinforcement

are not, the forms should be adjusted until they are square.

The most common types of reinforcement are made of steel. Steel has high tensile strength, which helps resist the forces acting on the concrete. To be effective, the steel used in concrete for reinforcement must be clean and free of rust and organic debris like leaves. In some cases, specially manufactured fibers can be added to the concrete as reinforcement in place of structural steel.

Steel rods are also commonly known as reinforcing bars, or rebar. Rebar can be purchased in a variety of sizes, from ¼ inch up to 2 inches in diameter. These rods are typically sold in lengths of 20 feet and are cut to fit. Steel rods are identified by a number, such as 2, 3, 4, 5, or 6. These numbers refer to the diameter of the rod, expressed in eighths of an inch. Number 4 rebar is ½ inch in diameter.

The other common type of reinforcement is steel wire mesh. Wire mesh consists of rods of steel wire joined in a crisscross pattern to form a mesh.

The steel comes in a number of different diameters, ranging from 0000, which is thin, up to 16 gauge. Meshes also differ in the spacing between the wire rods in the mesh. Common spacings are 2, 3, 4, 6, 8, 10, 12, and 16 inches.

Rolls of wire mesh are commonly sold in widths of 36, 42, 48, and 60 inches. Common lengths are 150, 200, and 300 feet.

Installing Reinforcement

Steel reinforcement should be placed in the bottom half of the slab, where the tensile forces on the concrete are the greatest. The reinforcement is placed approximately 1 inch above the soil or fill by wiring it to 12-inch rebar stakes that have been driven into the ground. Both rods and wire mesh need to be joined where they meet. Rebar should overlap by a length that is equal to 24 times the diameter of the rod and not less than 12 inches, while mesh should be overlapped one full square spacing plus 2 inches. The reinforcement should be tied with thin wire where the bars or wire mesh meet.

When installing steel reinforcement, be sure to place the rebar or mesh around the outside edges of the slab. However, the ends of the

reinforcement should be placed at least 3 inches from the very edge of the slab, so that it does not eventually stick out of the edge of the concrete and pose a hazard. After the rebar or mesh is in place, concrete is poured on top of the reinforcement. Sometimes the edges of the concrete are thickened to provide additional reinforcement for the rebar. Thickened edges involve placing a thicker, deeper layer of concrete at the edges of a concrete slab as a type of footing. The edge should be 4 to 6 inches thicker than the slab itself. The base of the thickened area should be 12 inches wide, with a 45-degree slope from the bottom of the main slab to the bottom of the thickened edge, as shown in Figure 4.1. This type of reinforcement is used on the perimeter of feeding floors and driveway edges where livestock or vehicles enter the paved area.

Expansion and Control Joints

Larger slabs of concrete like a concrete pad or sidewalk will at times move for various reasons, such as settling or pressure. A way to reduce the cracking of the concrete that results is to use expansion and control joints. Expansion and control joints may either be grooves made in the concrete or material placed in the concrete to prevent breaks or control where the concrete breaks. Joints can often prevent breakage, but if the concrete does break, these devices will also limit the location and force the break to form a straight line. The straight grooves commonly seen across sidewalks and driveways are expansion and control joints.

Expansion and control joints can be made using several different methods. For joints consisting of grooves in the concrete, a piece of angle iron, which is L-shaped, or a V-shaped piece of wood can be pushed in a straight line through the drying concrete. A mason's trowel can also be used to inscribe a groove into the drying concrete. Another method is to saw grooves in the concrete. These joints are cut into the dried concrete with a masonry saw 4 to 12 hours after the concrete is poured. The depth of the groove created using each of these methods will be less than one inch. An alternative method of installing expansion and control joints is to place small strips of IKO board on edge in the form

Materials Science and Technology (MAST) Teacher's Workshop. "Concrete." Produced by the Department of Materials Science and Engineering at the University of Illinois,

in place, concrete is poured on top of the reinforcement.

before the concrete is poured. IKO board is soft and spongy and is sometimes used to make bulletin boards. The board will expand and contract as the concrete dries and shrinks or moves due to expansion and contraction. Both of these types of control joints may be used in some situations.

Expansion and control joints should always be placed in straight lines perpendicular to each other in the concrete slab. The joints should make squares in the concrete and can be formed using a framing square. For slabs 4 inches thick or less, joints should be made in the concrete every 10 feet. For slabs 6 inches thick, joints should be included every 15 feet.

Summary

Pouring a concrete slab is a common task when working with concrete. Knowing the proper tools to use, the proper methods of forming and reinforcing concrete, and how to control expansion and breakage will result in a higher quality finished product.

Credits

Ahrens, Donald L. *Concrete and Concrete Masonry*. St. Paul, Minn.: Hobar Publications, 1976.

Boyd, James S., and Carl L. Reynolds. *Practical Farm Buildings*. 3rd. ed. Danville, Ill.: Interstate Publishers, 1993.

Cooper, Elmer L. *Agricultural Mechanics: Fundamentals and Applications*. Albany, N.Y.: Delmar Publishers, 1997.

Lindley, James A., and James H. Whitaker. *Agricultural Buildings and Structures*. Rev. ed. St. Joseph, Mich.: American Society of Agricultural Engineers, 1996.

Urbana/Champaign.
<http://mach-pc66.mse.uiuc.edu/~tw/concrete/concrete.html> (29 Aug. 1998).

Concrete

The Concrete Pages. "Control Joints for
Concrete Slabs."
<http://www.concretepages.com/tcjts.html> (19 Oct.
1998).

Lesson 5: Ordering, Pouring, and Finishing Concrete

Lesson 5: Ordering, Pouring, and Finishing Concrete

After preparing the forms for a concrete slab, the next step is pouring the concrete. Before the concrete can be poured, however, it must be ordered and mixed.

Calculating the Concrete Quantity Needed

Once the forms are ready, the process of pouring the concrete can begin. In instances where the volume of concrete being poured is larger than one yard, most people will order the concrete from a ready-mix plant and have it delivered to the site. This practice eliminates the need for obtaining the materials and equipment to mix the concrete on site. If the concrete is purchased from a ready-mix contractor, an order for the amount of concrete needed must first be calculated.

Concrete from a ready-mix plant is ordered in cubic yards, which is the standard volume used when working with concrete; one cubic yard is equal to 27 cubic feet. Plants typically sell the concrete at \$50 to \$70 per cubic yard plus a delivery charge. Since concrete is somewhat expensive, care must be taken to accurately determine how much is necessary. Once the concrete arrives, all of it must be used, or it becomes waste.

To calculate the number of cubic yards needed when pouring concrete for a rectangular slab, multiply the length, width, and depth in feet of the slab, and divide this number by 27, as shown in Figure 5.1.

Using this equation, 3.56 cubic yards are required for a slab that is 12 feet by 16 feet by 6 inches ($12 \times 16 \times .5$, divided by 27). If this were the only concrete poured that particular day,

$$\text{Length (ft.)} \times \text{Width (ft.)} \times \text{Depth (ft.)} \times \frac{yd.^3}{27 ft.^3} = \text{Cubic yards of concrete}$$

Certain conditions may affect the type of cement

4 yards of concrete would be ordered, since most ready-mix plants sell only whole yards of concrete.

If the slab to be poured is circular, the formula for the volume of a circle is used to calculate the amount of concrete needed, as illustrated in Figure 5.2.

A concrete slab 4 inches thick under a grain silo that is 24 feet in diameter would require 5.53 cubic yards of concrete ($3.14 \times 12 \times 12 \times .33$, divided by 27).

When ordering concrete, the amount ordered will usually be more than the amount calculated by a factor of 10 to 25 percent. The amount needed is multiplied by 1.1 or 1.25 to provide the extra concrete. This additional material will make up for any spilled concrete and differences in soil or fill level, especially for low spots.

Factors to Consider When Ordering Concrete

When deciding to order concrete, several issues need to be addressed. Factors to consider include the weather, conditions affecting the type of concrete needed, labor needs and availability, access to the area by truck, and water needs.

The weather should be considered when ordering concrete. Concrete should preferably not be poured in a rain storm or when temperatures are below 40 degrees or above 85 degrees. These weather conditions will affect the rate of curing, or hardening, of the concrete as well as the overall final strength of the concrete. If concrete must be poured in cold weather, calcium chloride has to be added to the mix.

ordered. The concrete mix may include

$$\pi (3.14) \times \text{Radius}^2 (\text{ft.}^2) \times \text{Depth (ft.)} \times \frac{yd.^3}{27 ft.^3} = \text{Cubic yards of concrete}$$

Concrete

different types of portland cement depending on different conditions. For example, if the concrete is to be poured on alkaline soils or in areas where heat may build up, a particular type of concrete mix is used. Other mixes are required if the concrete needs strength in the first two to three days or if the heat generated by the concrete needs to be reduced, as for large water dams.

Labor needs and availability should also be considered. Pouring and finishing concrete is not a one-person job. The arrival of the delivery truck should be timed to occur when sufficient labor will be available to pour and finish the concrete.

Another factor to consider is the access and elevation of the delivery truck. Most ready-mix businesses offer trucks with extension slides to allow the concrete to be poured over greater distances and avoid hauling the concrete in wheelbarrows. Companies generally also have a few trucks that can pump the concrete to a location higher than the tires of the truck.

Water needs are another consideration. Water is important in the process of pouring concrete. The site needs to be sprayed with water if the fill is dry. The concrete is sprinkled with water as it cures to increase the moisture content and improve the strength of the finished concrete. Water will also be used to clean all the equipment.

Pouring a Slab

After the desired amount of concrete has been determined, ordered, and delivered, the concrete is poured. The process of pouring concrete has several steps that need to be followed closely.

Before the concrete can be poured into the forms to cover the reinforcement, the site needs to be moistened. This task needs to be done while the concrete is being delivered or mixed on site.

The concrete should be poured as soon as possible after its arrival at the site or after being mixed. This procedure will maximize the amount of moisture in the concrete, increasing its strength. Pouring it right away will also aid in maintaining the proper slump, or the correct moisture level of the concrete.

An important point to remember is that concrete begins to set 30 to 60 minutes after pouring. If the concrete is moved in any way during the first hour after pouring, its strength is reduced. For this reason, the truck or mixer should be moved as close as possible to the final location of the concrete to avoid having to move the concrete in wheelbarrows.

When unloading the concrete from the truck, the chute or discharge tube should be placed as close to the ground as possible. If the chute is too high, the impact of the concrete hitting the ground will partially separate the aggregate from the cement mixture.

As the concrete fills the forms, a shovel or spade should be pushed through it, especially at the edges of the forms. The aggregate will then be well mixed and moved away from the edges somewhat, resulting in a smoother finish at the edge. Working through the concrete will also remove any air bubbles that may have resulted from pouring, giving the concrete more strength.

If the slab to be poured is wider than 10 feet, pouring the slab in two or more sections should be considered. Slabs wider than 10 feet will be more difficult to finish, since most concrete finishing tools do not have handles long enough to reach the entire area.

Concrete Finishes

Finishing is the process of working the surface of concrete to give it texture. Concrete can be finished using several different methods, which will result in different textures on the exposed surface. The finish selected will depend on the final use of the concrete. One type of finish creates a smooth surface, which is used where ease of cleaning is required, as for floors in a shop, house, or grain bin. Another method of finishing concrete provides a rough surface, which is used for traction on sidewalks, livestock walkways, inclined walks, and steps. A third type of finish is an aggregate finish, which is used for traction and decorative purposes and consists of exposed rocks on the surface of the concrete; it may be used anywhere a decorative surface is desired, such as sidewalks.

Finishing the Concrete

As one crew is pouring concrete, another crew can begin the finishing process after the

Lesson 5: Ordering, Pouring, and Finishing Concrete

concrete has begun to harden and its surface starts to dry out. The finishing crew will work the concrete to provide a flat, even surface that will be attractive as a finished product. They For a smooth surface finish, the first step is to screed the concrete. Screeding involves moving a board across the concrete along the top of the forms. This process will move concrete into lower spots inside the form and remove excess concrete. Screeding is typically done by moving a straight 2" × 4" board back and forth at a 90-degree angle to the edge of the form.

After the concrete has been screeded, a bull float is used to work the aggregate below the surface. A bull float is a wide board or flat piece of aluminum that is held level with the surface and tipped up slightly along the front edge as it moves across the concrete. The float will force the aggregate below the surface, leaving the concrete relatively smooth. Unfortunately, it also leaves small ridges in the concrete.

These small ridges are then removed using a power trowel, a steel hand trowel, or a magnesium hand float, which is similar to but slightly longer than the steel trowel and gives a smoother final surface. If the person pouring the concrete has access to a power trowel, it should be used. The power trowel is worked in a circular pattern to smooth away any edges, leaving a very smooth surface overall. If a power trowel is not available, a steel hand trowel can be used to achieve the same effect. The hand trowel or a magnesium float should be worked using a curving motion similar to the movement of windshield wipers on a car, with the edge of the tool sloping slightly upward as it is moved across the concrete to help compact the surface. Troweling is illustrated in Figure 5.3.

An edger should be used along the forms as the

will also give the concrete the proper texture. Each type of finish requires a different procedure.

concrete begins to set to separate it from the forms and leave a slightly rounded edge, as shown in Figure 5.4. At the same time, expansion and control joints should be applied if they are needed.

The process is similar for a rough surface finish. The concrete is screeded to even out the surface of the concrete, and a bull float is used to force the aggregate down. The ridges are removed using a power or hand trowel. The final step in rough surface finishing involves pulling a push broom across the surface of the curing concrete.

The bristles will leave small, even grooves in the concrete that will reduce slippage and increase traction, especially when water freezes on the surface. An edger is used along the forms, and expansion and control joints are then applied.

An exposed aggregate finish creates a pebbly or rocky surface that is not smooth at all. For this type of finish, the concrete is again screeded and worked with a bull float. It is then lightly worked with the power or steel trowel, with less concern for creating a smooth surface. To add the aggregate to the finish, a layer consisting only of aggregate is applied evenly over the surface of the concrete. This layer is embedded using a board similar to the screed to force the aggregate into the concrete to a depth of about one half of its diameter. The aggregate should not be forced too far into the concrete, because the desired finish will be reduced. The concrete is then allowed to dry until surface water disappears. After the water has evaporated and the mixture can support a person's weight, a hose and bristle broom are used to remove any film of concrete on the surface of the exposed aggregate.

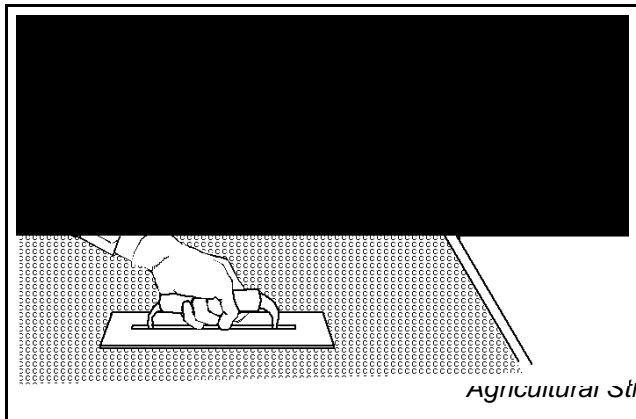

Concrete

Summary

Ordering concrete for a specific job requires accurate calculations to determine the correct amounts needed. Factors such as the weather, conditions affecting the type of concrete needed, labor needs, access to the area, and availability of water should be considered. Once the concrete has arrived, efforts should be made to pour the concrete as soon as possible using the proper process. After the concrete starts to harden, it must be finished to meet the needs of the situation. If the concrete is poured and finished well, the result is high-quality concrete that will last for many years.

Credits

Ahrens, Donald L. *Concrete and Concrete Masonry*. St. Paul, Minn.: Hobar Publications, 1976.

Boyd, James S., and Carl L. Reynolds. *Practical Farm Buildings*. 3rd. ed. Danville, Ill.: Interstate Publishers, 1993.

Cooper, Elmer L. *Agricultural Mechanics: Fundamentals and Applications*. Albany, N.Y.: Delmar Publishers, 1997.

Lindley, James A., and James H. Whitaker. *Agricultural Buildings and Structures*. Rev. ed. St. Joseph, Mich.: American Society of Agricultural Engineers, 1996.

Materials Science and Technology (MAST) Teacher's Workshop. "Concrete." Produced by the Department of Materials Science and Engineering at the University of Illinois, Urbana/Champaign. <http://mach-pc66.mse.uiuc.edu/~tw/concrete/concrete.html> (29 Aug. 1998).

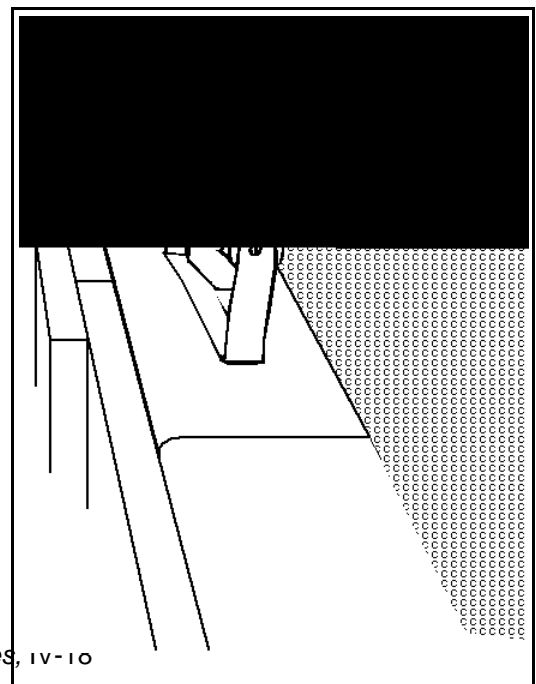

Lesson 6: Curing Concrete

Once concrete has been poured, the curing process begins to take place. While it may seem that the concrete is merely drying, a chemical process called hydration is in action. Curing is necessary because this chemical process gives concrete its strength. If it does not cure properly, the result is substandard concrete.

The Process of Concrete Curing

After concrete has been poured into forms and exposed to the air, it begins to harden in a process called curing. Most people think that concrete hardens because of evaporation or drying, but they are not correct. If concrete were to simply dry out, nothing would hold it together, and the materials would separate out. The curing of the concrete is the result of hydration, which is the mixing of a compound with water.

The curing process involves a chemical reaction between water and the elements in Portland cement. As the cement starts to react with the water, a substance called a gel is formed from the chemicals in the cement and water. The gel has a consistency similar to gelatin. Eventually the gel becomes a solid mass, thickening and hardening the concrete.

The rate of curing for pure concrete without additives is affected by temperature. The ideal temperatures for curing are between 65 and 75 degrees Fahrenheit. Temperatures higher than 75 degrees will cause the concrete to cure too quickly by creating excess evaporation; the concrete will then lose strength. In temperatures between 32 and 65 degrees Fahrenheit, concrete will cure, but the process will be slower. At temperatures below 32 degrees, the concrete will not cure. If concrete freezes during curing, permanent damage will occur.

The length of time that pure concrete is allowed to cure depends on the outside temperature. Generally, if air and soil temperatures are above 70 degrees Fahrenheit, the concrete should be allowed to cure for at least five days. If temperatures are 50 to 70 degrees Fahrenheit, the concrete should be allowed to cure for at

least seven days. If the temperature is less than 50 degrees Fahrenheit, the concrete should cure for at least seven to ten days, and preferably longer. In all cases, the ideal curing time is 28 days, because the process continues until about that time.

No extra weight should be placed on the concrete during curing because it will stop the curing process. Keeping weight off the concrete will also increase its final strength. Construction of the structure should wait until the concrete has completely cured.

Determining if the concrete has cured completely is difficult. The outside layer or shell of the concrete will cure first, with the inside curing last.

No direct method exists for determining if the concrete on the inside has cured. The outside is cured when the concrete becomes light gray in color.

The Importance of Curing

Curing is important because it causes the concrete to harden and determines its strength. To a point, the more water the concrete can retain, the greater its strength will be. For maximum strength, the concrete must have adequate water to continue the chemical reaction until it has completely hardened. Only about half of the water in concrete is needed for hydration. The rest is needed to make the concrete flow and be workable. Too much water will cause incomplete curing because the gel particles cannot join together to harden and set.

Curing also gives concrete the ability to hold water in or out. Because so many concrete applications call for the ability to contain water or keep it out, curing is very important. For example, if the walls in the basement of a house do not completely cure, water will seep in from the soil, and moisture will always be present in the house. Concrete cured for only one day would not be waterproof, while concrete cured for three days would be somewhat but not completely watertight. Concrete cured for seven days is completely watertight.

Curing Concrete

One of the most important factors affecting curing is the temperature. Different approaches

Concrete

are necessary when curing concrete in temperatures below 50 degrees Fahrenheit or
Cold Weather Curing

Concrete should never be poured onto frozen soil because the ground will cause the water in the concrete to freeze, halting the curing process completely. The ground should be heated using propane torches.

When pouring concrete in temperatures below 50 degrees Fahrenheit, the concrete should be heated so that it is between 60 and 80 degrees Fahrenheit as it hits the forms. The concrete can be heated by heating the water added to the mixture.

After pouring, protection should be provided for the forms in order to retain the heat in the concrete. This protection can be in the form of straw, plastic, or paper spread directly on the surface of the concrete, sealing the heat and moisture in. The cover should remain over the concrete for at least 48 hours and preferably for four to five days.

Another option for heating the concrete is to build an enclosure around the forms and heat the entire area with fuel-burning heaters. Heaters should be used with caution, because the carbon dioxide they give off will sometimes react with the concrete to form a thin layer of calcium carbonate over its surface, which will be weak and chip off. To avoid this problem, adequate ventilation for the exhaust fumes from the heater is necessary.

The forms should be left around the concrete for as long as possible. They will act as insulation, retaining the heat in the concrete.

One way to test whether the concrete froze during curing is to pour hot water on it. If the concrete has cured properly, nothing will happen.

If the concrete did freeze, however, its surface will become soft and mushy. The concrete will need to be chipped or broken out and poured again.

Hot Weather Curing

In hot weather, some important factors need to be considered to allow maximum curing. If outside temperatures are above 80 degrees Fahrenheit, more water will be needed in the

above 80 degrees Fahrenheit.

concrete mixture to maintain the optimal slump of 1 to 3 inches because some of the water evaporates due to the heat and mixing. High temperatures will also shorten the time that the concrete can be worked or finished because of the more rapid evaporation of the surface water.

Reducing the time needed for pouring by having plenty of labor available is important in warm temperatures. The more time it takes to place the concrete, the more water will evaporate, affecting curing.

Hot weather can cause incomplete curing due to the rapid curing of the outside layer of the concrete. Although the outside is cured, the inside may not be. This condition is difficult to detect and may not be noticed until later, when the concrete does not have sufficient strength for a given situation.

Several methods can be used to keep the concrete cool. The easiest method of maintaining the optimal temperature is to cool the ingredients of the concrete as they are mixed.

The temperature of the mix can be reduced by adding cold water. Dampening the subgrade will reduce the heating of the concrete as it is poured into the forms. Wet burlap can be placed over the concrete to help cool the surface.

Lightly spraying cold water on the concrete will also cool it. However, the concrete should only be sprayed once the surface has been finished and has hardened, so it does not show indentations from the water droplets.

Moist Curing

Another factor that affects curing is moisture. Ideally, concrete should be cured with as little moisture evaporating from the surface as possible. Retaining the moisture on the surface of the concrete is called moist curing. Moist curing can be accomplished using a variety of methods. Some of these methods include placing moist burlap sacks over the surface of the concrete, spraying the surface with water, covering it with waterproof paper, covering the surface with plastic sheets, or spraying the concrete with a curing compound, which places a chemical membrane over the concrete to seal in the moisture. Four main types of curing compound are used: clear or transparent, black, white, and light gray. These curing compounds

may cause a permanent change in the color of the surface of the concrete.

Concrete defects are faults in the surface of the concrete. They are usually only apparent after curing. These defects have many different causes, including poor materials, improper mix design, improper pouring and curing, or poor workmanship. The faults are difficult, if not impossible, to repair without tearing out the faulty concrete and replacing it.

Honeycomb surfaces result from the use of a concrete mixture that was too dry and needed more water to mix completely. The lack of water causes air pockets around the unmixed dry materials, resulting in a honeycomb structure.

To prevent honeycomb faults, the mix must be moist enough. The edges of the forms should also be spaded to avoid dry spots.

Air pockets are holes left in the concrete after curing due to the presence of a confined body of air. They can generally be prevented by spading the edge of the forms. Wiping oil on the surface of the forms will decrease the frequency of air pockets because the oil allows the air to escape more readily.

Rock pockets or gravel streaks are related defects caused by cracks or knotholes in the forms that allow the mortar, which is the cement and water paste, to flow out, leaving pockets and veins of coarse aggregate. While these faults can easily be prevented, they are generally difficult to repair.

Sand streaking involves small ribbons of sand running across the surface of the concrete. This defect is usually caused by a mixture that was too wet. As a result, the coarse aggregates sink and separate out from the rest of the mixture, leaving the fine aggregate to work to the top. This fault is difficult to repair.

If the surface of the concrete is stained red to pink in color, the coloring is the result of the resin in the plywood forms reacting with the concrete. The discoloration will generally happen with forms used for the first time and will diminish with continued use. Using older forms will greatly reduce this problem. The color is difficult to remove from concrete but will fade and disappear in time. Since it is not permanent,

Concrete Defects

this defect does not greatly affect the quality of the concrete.

Rust stains are caused by steel reinforcement that has worked to the edge or surface of the concrete. If the reinforcement is fully covered by concrete, these stains will not occur. The stains can be cleaned from the concrete using a chemical solution of diluted oxalic acid but will reappear as long as the exposed metal is present.

Dusting is the appearance of a powdery material on the surface of newly hardened concrete. Dusting has several different causes, including excess clay or silt in the concrete, premature floating and troweling, the addition of carbon dioxide from heating systems, the condensation of water on the surface before floating and troweling have been completed, dry-heat heaters that lower the humidity too quickly and cause incomplete curing, or inadequate or no curing due to insufficient water in the mixture. Dusting cannot be fixed, only prevented. If the concrete has dusted, it will have reduced strength. The concrete may need to be chipped or broken out and poured again if it is not strong enough.

Scaling occurs when the surface of hardened concrete slabs breaks away to a depth of 1/16 to 3/16 of an inch. This defect may be caused by the freezing and thawing of newly placed concrete, the freezing and thawing of concrete that is not air-entrained, the application of deicing salts on concrete that is not air-entrained, and faulty workmanship caused by finishing the concrete while it was still "bleeding" or giving off water. Scaling cannot be repaired.

Crazing is the presence of numerous fine hairline cracks in the surface of a newly hardened slab due to shrinkage. Crazing can be caused by rapid surface drying by the sun or wind, premature floating and troweling on a moist surface along with the rapid loss of moisture, or the overuse of tools such as a power screed or bull float, which works too much mortar to the surface of the concrete. Crazing cannot be corrected.

Removal of Forms

Forms can be removed when the concrete has cured sufficiently to support its own weight. The amount of time will vary according to the weather.

In summer or warm weather conditions, the forms can be removed two days after pouring. In winter or cold weather conditions, the forms should not be removed for at least four to seven days. Forms can be removed in less time if accelerating additives are used; they can cut the curing time in half. Any reinforcement around the forms should be loosened prior to their removal, including all the duplex nails holding the forms together. If the forms were properly coated with oil, they should come away easily, without the use of force. The forms should then be cleaned to remove any concrete residue before storing them away for future use. The slab can be cleaned with water once the forms have been removed.

Summary

Curing is the hardening of concrete, which gives it strength and allows it to resist water. Curing requires temperatures of 65 to 75 degrees Fahrenheit for optimal curing, although curing concrete in hotter and colder temperatures is possible using the proper additives and procedures. Many defects may occur if the concrete is mixed, poured, worked, or cured improperly, resulting in concrete that is weak or has a poor appearance.

Credits

Ahrens, Donald L. *Concrete and Concrete Masonry*. St. Paul, Minn.: Hobar Publications, 1976.

Boyd, James S., and Carl L. Reynolds. *Practical Farm Buildings*. 3rd. ed. Danville, Ill: Interstate Publishers, 1993.

Cooper, Elmer L. *Agricultural Mechanics: Fundamentals and Applications*. Albany, N.Y.: Delmar Publishers, 1997.

Granite Rock Company. "Concrete Surface Defects - Causes, Prevention and Repair." <http://www.graniterock.com/tn.htm> (12 Dec. 1998).

Lindley, James A., and James H. Whitaker. *Agricultural Buildings and Structures*. Rev. ed. St. Joseph, Mich.: American Society of Agricultural Engineers, 1996.

Materials Science and Technology (MAST) Teacher's Workshop. "Concrete." Produced by the Department of Materials Science and Engineering at the University of Illinois, Urbana/Champaign. <http://mach-pc66.mse.uiuc.edu/~tw/concrete/concrete.html> (29 Aug. 1998).

Lesson 7: Pouring Concrete Walls

Lesson 7: Pouring Concrete Walls

Concrete walls are common in construction. They may be used for the sides of a building or for pits to store silage or manure. Also, when building a house, many people prefer to have a crawl space or basement under the house. In order to have these items, a concrete wall must be poured on top of the footings to support the rest of the building. This lesson will discuss the equipment and procedures used in pouring concrete walls.

Tools for Pouring Walls

Many of the tools needed for pouring a concrete wall are the same as those used for slabs, Aluminum or metal forms are also made for walls. The use of metal forms will produce straighter walls because the metal does not bend from the

although some additional items are necessary. The tools and equipment needed to pour a concrete wall include a trowel, steel tamp rod, shovel, hand level, tape measure, circular saw, and hammer for nailing forms together.

Types of Forms

Several materials are commonly used to construct forms for pouring concrete walls. Wood is the most commonly used material. The forms are typically constructed of plywood made with an exterior glue, which is waterproof and will not come apart when exposed to moisture. Plywood forms are illustrated in Figure 7.1.

weight of the concrete as much as wood forms do. However, metal forms are more expensive than plywood forms.

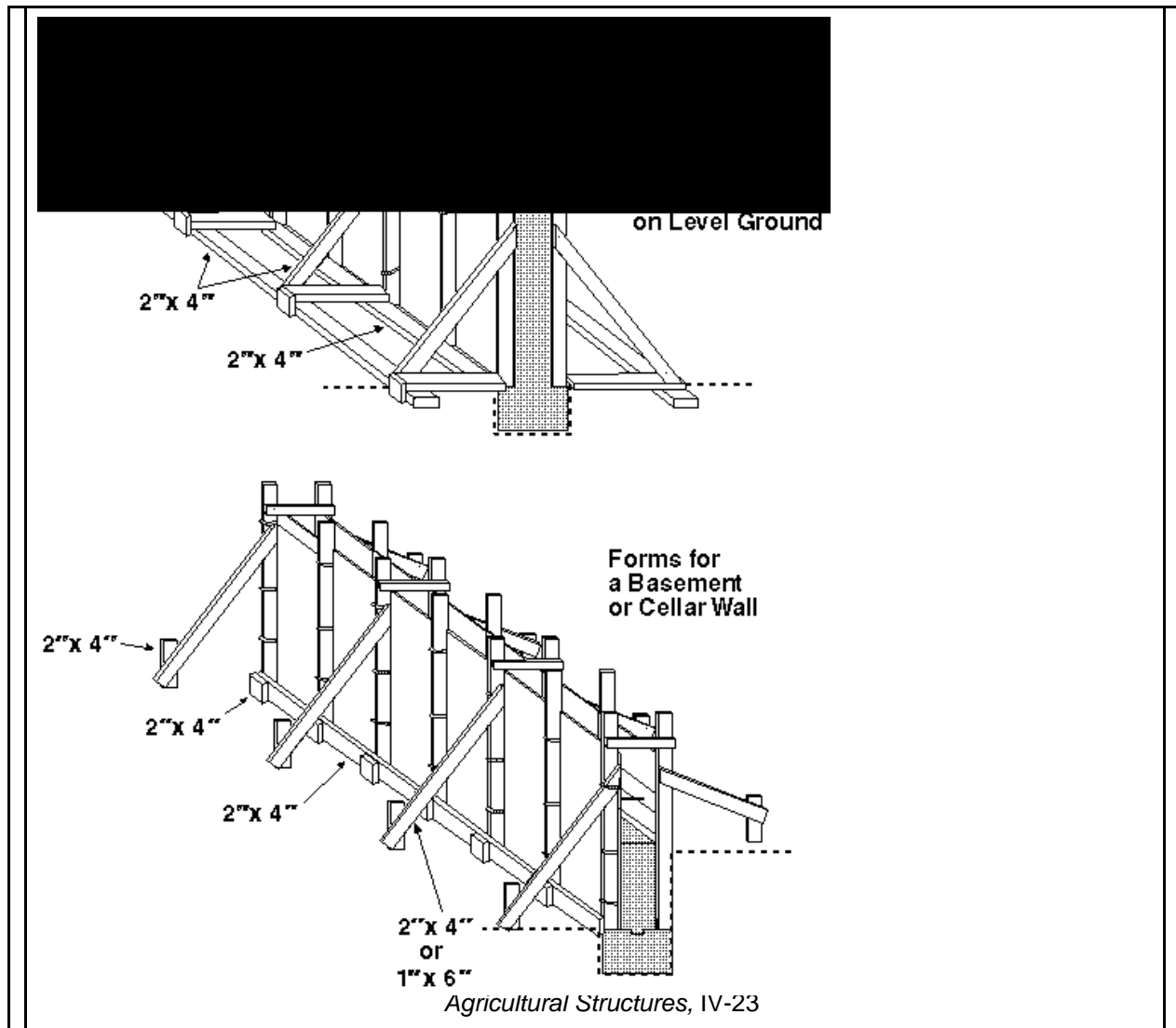

Concrete

A new type of wall form has been developed in the last few years. These forms are made of Styrofoam with steel mesh embedded in it to add strength to the form. With this type of form, the form is not removed after the concrete is poured into it. Instead, it becomes a permanent part of the wall. Styrofoam forms have several shapes, including one resembling cinder blocks.

Styrofoam forms have several advantages and disadvantages. Less labor is required because the forms are not removed. They allow for construction in all types of weather because moisture will not alter the form as it does wooden forms. The forms are lightweight and snap together for ease of construction. Less bracing is required than with wooden forms. Wiring and pipes can be run through these forms easily because they provide passages through the concrete for plumbing and electricity; with Stake - Stakes are typically made from a 2" x 4" board, which will allow the form to be braced to

standard forms, wires and pipes will have to be run on the outside of the concrete wall. The forms are energy efficient, as the Styrofoam is an insulator and will serve as insulation for the wall. Finally, the finished product can be finished or painted with exterior paint. A disadvantage of Styrofoam forms is that the forms are not reusable. They are also much more expensive than wooden forms and slightly more expensive than the metal forms.

Constructing Forms for Walls

Since most concrete forms are made of wood, this section will concentrate on how to build wood forms, which have several parts. The parts of a wooden form are illustrated in Figure 7.2.

keep it straight and vertical. For strength, they are placed 4 feet apart or less.

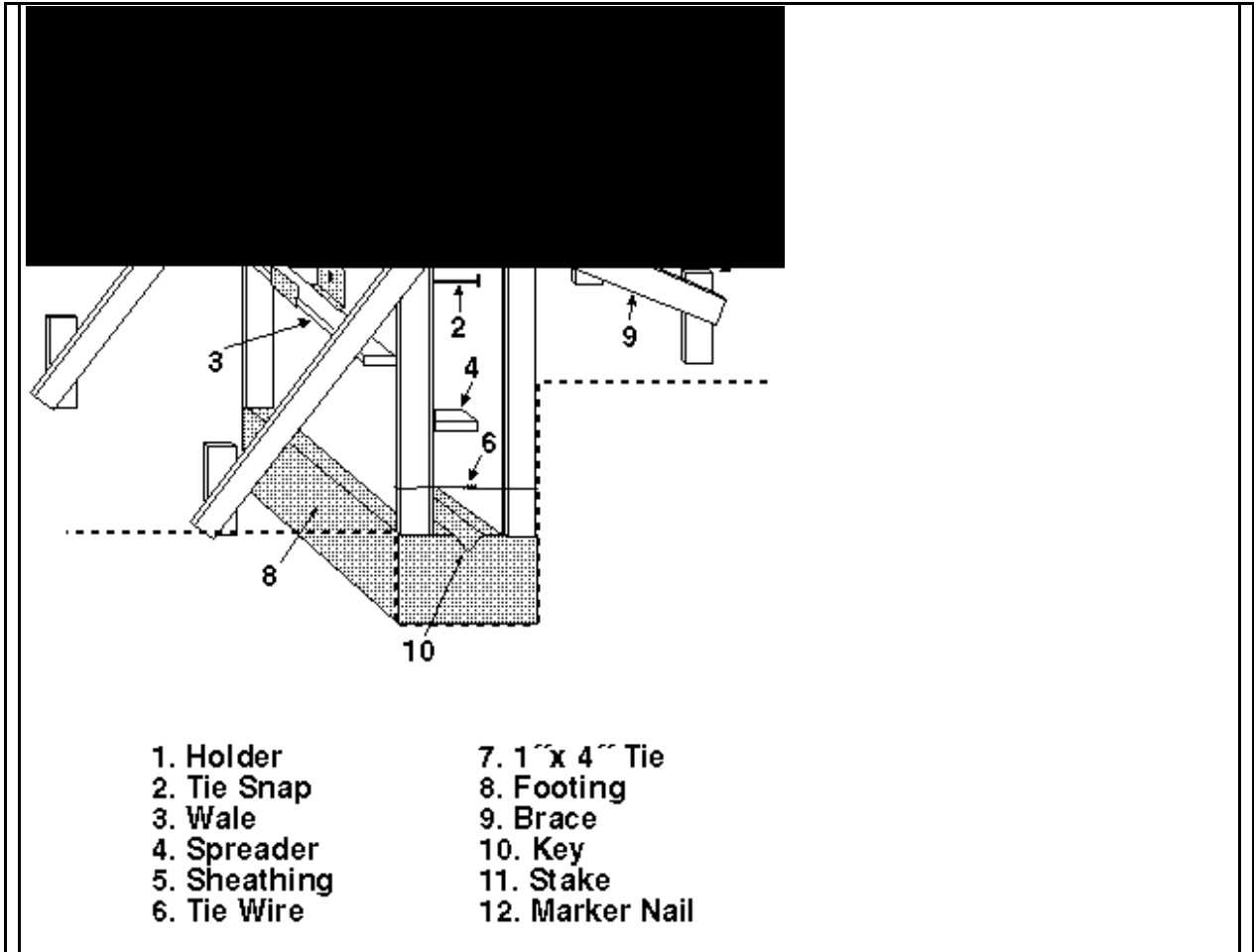

Lesson 7: *Pouring Concrete Walls*

Brace - Braces are nailed to the stake and the form to help keep the forms vertical. Braces can be cut to the correct lengths needed with a circular saw.

1" x 4" tie - The ties keep the two sides of the form apart to give the wall the desired thickness. Each end of a tie is nailed to one side of the form.

Sheathing - The sheathing that forms the sides of the form is typically made of plywood.

Wale - A wale is a 2" x 4" board that prevents the wall from bulging outward due to the weight of the concrete. It is nailed to the form with the wide side down.

Holder - Holders, which are typically made of metal, hold wales and snap ties in place. Once the sheathing is standing in place, the holder is placed over the snap ties and wales are placed in the holder. The holder holds the entire form together.

Snap tie - Snap ties are specially constructed pieces of wire that will run through the concrete wall. Snap ties help hold the forms the correct width apart. The snap tie has a wider spot that allows the holder to clamp tight on it without slippage. Once the concrete has set and before attempting to remove the forms, the holders should be removed, and the ends of the ties can be snapped off by bending them back and forth.

Spreader - A spreader typically consists of a 2" x 4" board cut to a length that is equal to the thickness of the wall. Spreaders are placed inside the form to keep its sides apart while the concrete is poured. During pouring, the spreaders are removed just before the concrete reaches that level.

Wire tie - Like snap ties, wire ties hold the forms the correct width apart. Wire ties are used on the ends of a form, while snap ties are used in the middle. They are constructed of twisted wire and are broken off after the concrete sets.

Key - The key is a groove made in the footing that will allow the concrete from the walls to bond to the concrete in the footing.

Marker nails - Marker nails are driven through the form from the outside to mark the desired height of the concrete if it will not be poured to the top of the form. These nails are removed when the concrete reaches the desired level to allow the surface to be worked with a trowel or float.

Assembly of the forms begins with standing the sheathing upright where the wall will be poured. The holders, snap ties, and wales should be put on to hold the two sides together. Spreaders can be added on the inside of the form at this time. Next, stakes are placed in the ground about 5 to 8 feet away from the form and the braces are cut to the correct distance to reach the stakes. The form should be checked using a level to make sure it is level and plumb, or straight up and down. If the forms are not level and plumb, adjust the braces until the form is correct. Then the braces are nailed to the forms and the stakes to hold the forms in the correct position. After the braces and stakes are in position, the wire ties are placed on the ends of the forms, and the 1" x 4" ties are secured to the ends of the forms with duplex-head nails.

The forms must be square, because if they are not, the building will not be square. The diagonal method is used to check whether they are square. If the diagonals are not equal, the form will have to be adjusted.

All of the pieces on the form must fit tightly together, and the forms must be strong. They should be checked prior to pouring the concrete. Forms that are loose or weak will lead to blow-outs, or concrete flowing out of weak spots in the form that break due to the weight of the concrete. Usually these weak spots occur at corners or where two forms meet. These spots can be braced using additional 1" x 4" ties and duplex-head nails attached diagonally across the corners, or across the joint where the forms meet.

High quality lumber must be used in constructing forms. Weak spots from cracks, knot holes, or other problems will reduce the strength of the form.

Reinforcement of Walls

Concrete

After the forms have been set up and are square, reinforcement can be added. Just like slabs, walls require reinforcement. Typically they are reinforced with rebar. The rebar should be placed in the middle of the wall at an equal distance from each side of the form, and it should not stick out the top. The rods are placed length-wise through the walls, spaced 8 to 12 inches apart. Rods are driven vertically in the ground every 4 feet to support the horizontal rods. The vertical and horizontal rods are tied together using thin wire.

Pouring the Walls

The process for pouring concrete walls is relatively simple. Before filling the forms with concrete, they should be lightly oiled to prevent the concrete from sticking. The concrete is then poured from one end or corner, working along the wall. The corner must be filled before moving on to the rest of the wall. Enough concrete should be poured in one spot to fill the form before moving so that the concrete does not have to be shoveled backward to fill low spots. Spreaders must be removed as the form is filled. When the form is filled to the desired level, the steel tamp rod is run up and down through the concrete to help work out air bubbles.

As soon as one wall is finished, another wall can be started if the forms are in place.

After each of the walls has been poured, the top surface of the concrete must be smoothed and leveled. The top surface needs to be flat and relatively smooth so a wall that is built on top of it will seal against the concrete and not allow air to leak into the building. This task can be done using a small trowel or a board cut the width of the wall. The tool is worked along the top of the forms in a process similar to screeding.

After the first wall has been leveled and smoothed and the surface starts to dry, anchor bolts can be inserted into the concrete. Anchor bolts are standard bolts that are placed with the head of the bolt in the moist concrete. These bolts will anchor the wooden portion of the structure. They should be at least 3/8 of an inch in diameter and are typically 4½ to 5 inches long. Anchor bolts are generally set at least 2 inches into the concrete. The bolts should be straight.

Anchor bolts are spaced 4 to 6 inches apart along each side of the building, with one bolt set in from the corner near each end of a wall. The distance between them depends on the wind loads that will affect the structure. They should be only 4 inches apart in areas with more winds but may be further apart in areas with little wind. The anchor bolts will help secure the walls to the foundation in strong winds. The bolts should also be placed where they will not interfere with the upright studs in the walls. If an anchor bolt is located where the stud will be, either the stud will have to be moved, which would weaken the wall, or the bolt will have to be cut off, which decreases the wall's ability to resist winds.

Before the forms are removed, concrete walls should cure for at least one week, preferably longer. The concrete will take longer to cure because the outside air is not reaching as much of the surface.

When the concrete has cured enough, the forms are removed. All holders and wales are loosened first. The braces and stakes are then removed. Finally, the sheathing is carefully removed. They should come off without the use of excessive force. After the forms have been removed, the snap ties can be twisted back and forth until they break or snap off to leave a relatively smooth wall surface. If wire ties were used, cement paste can be used to fill in the holes left in the concrete.

Preventing the Entry of Moisture

Even though concrete is mostly waterproof, moisture may still flow through, especially at joints or cracks. To completely seal a concrete wall, the use of some method of repelling or removing moisture is necessary. A vapor barrier is a specially constructed protective material attached to the inside of the underground portion of a concrete wall to eliminate condensation. Waterproofing materials painted on the outside of a wall also prevent the entry of the water. Typically, they are made of polyurethane, rubber, tar, or other waterproofing compounds. It may also consist of a layer of polyethylene plastic glued to the outside of the wall that will repel water from the soil. Another way to keep water from entering the concrete is the use of a waterstop. Waterstops are synthetic materials placed between concrete construction joints to stop

Lesson 7: Pouring Concrete Walls

water from entering through the joints. Drainage pipes can also be placed around the structure to move excess water away, reducing the chance of water problems.

Pouring concrete walls is an important step in building construction. If the forms are built and braced correctly, the building will be square and strong. Care should be given to carefully constructing the forms, pouring the concrete, and allowing the concrete to cure. Properly reinforcing the concrete will yield much stronger walls that can withstand the years of pressure and stress from the weight of the building. A water stop can be used to completely waterproof a wall.

Credits

Ahrens, Donald L. *Concrete and Concrete Masonry*. St. Paul, Minn.: Hobar Publications, 1976.

Summary

Boyd, James S., and Carl L. Reynolds. *Practical Farm Buildings*. 3rd. ed. Danville, Ill.: Interstate Publishers, 1993.

Cooper, Elmer L. *Agricultural Mechanics: Fundamentals and Applications*. Albany, N.Y.: Delmar Publishers, 1997.

Lindley, James A., and James H. Whitaker. *Agricultural Buildings and Structures*. Rev. ed. St. Joseph, Mich.: American Society of Agricultural Engineers, 1996.

Materials Science and Technology (MAST) Teacher's Workshop. "Concrete." Produced by the Department of Materials Science and Engineering at the University of Illinois, Urbana/Champaign. <http://mach-pc66.mse.uiuc.edu/~tw/concrete/concrete.html> (29 Aug. 1998).

Concrete

Lesson 10: Cost and Electrical Power Use

Lesson 10: Cost and Electrical Power Use

Once the electrical system is in place, electrical consumption and the cost of electrical use becomes important. Four factors affect calculations related to electric power: watts, volts, amperes, and resistance. The relationship between these factors was first described in 1826 by a German physicist named Georg Ohm, who devised Ohm's Law for calculating electrical resistance.

The Power Equation and Ohm's Law

The power equation is a mathematical formula that expresses the amount of power used in an electrical circuit or system. It indicates the relationship between wattage (P), amperage (I), and voltage (E).

$$P = I \times E$$

This equation is primarily used to calculate power usage in watts, but the formula can also be used to determine the amperage or voltage of a system if the other two factors are known. These calculations are important when testing an electrical system for efficient operation and for calculating the power use of individual branch circuits or the total system.

Ohm's Law is a mathematical formula that expresses the relationship between electromotive force (E), electric current (I), and resistance (R). Electromotive force, which is measured in volts, is the pressure created by the movement of electrons from one point to another.

Electric current is measured in amps. The final factor, which is referred to as resistance in DC circuits, is measured in ohms. The formula for Ohm's Law is as follows.

$$E = I \times R$$

When working with AC circuits, impedance (Z) is used rather than resistance. Impedance describes the counter electromotive force created by the directional change in the AC circuit. The strength of the resistance depends on the rapidity of the directional change. The more frequently the electrical current switches

directional flow, the higher the impedance will be.

Ohm's Law is used to determine the energy efficiency of an electrical circuit, looking at factors such as voltage drop. It helps electricians determine if changes need to be made in a system, such as using fewer outlets or larger wire sizes. The equation can also help in determining if expanding an existing system is feasible.

To make calculations using the power equation or Ohm's Law, measurements of the electrical system must be made. Handheld electrical meters are available to measure each of the factors used in the equations. An ammeter measures amperage, while a volt meter measures voltage. A watt meter measures wattage, showing how much power is flowing through the system by analyzing both amperage and voltage. An ohmmeter measures resistance in the electrical system. These types of meters are used by electricians to test an electrical system.

Measuring Electricity

To calculate how much electricity is used, being able to read and understand the measurements used to check electrical consumption is necessary. Electrical power is measured by power companies using a watt-hour meter, which measures and instantly records electrical consumption in watts or kilowatts. The watt-hour meter is attached to the electrical system at the meter base, a socket that the meter plugs into. Meters are located at or near the service entrance panel in homes and on individual structures or at the power pole when a number of structures will be operating on the electrical service.

Two types of meters are commonly used. The newer type uses a rotating meter similar to the mileage indicator on a car. This meter is easier to read than the older type, which has several rotating pointers that turn as electricity is used, as shown in Figure 10.1. The following system

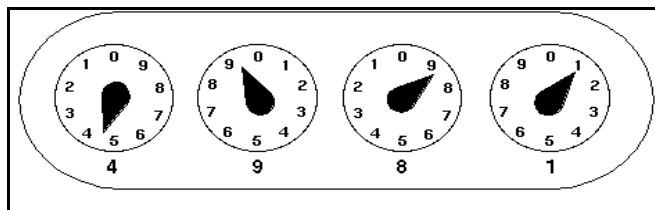

Electricity

is used when reading the pointer-type meter.

- The first dial is read counterclockwise.
- The second dial is read clockwise.

The numbers are written down from left to right. If the pointer is between numbers, the smaller number is read. The numbers give the kilowatt-hour usage for that point in time.

Determining the Cost of Electricity

Electrical bills are calculated on a monthly or bimonthly basis in most areas. The bills are based on a scale set up by the local electric company. Some companies use a sliding scale that decreases price as usage increases. Others use a fixed rate.

Calculating the cost of electricity requires the rate scale from the electric company and the total kilowatt-hours consumed. To determine the total use over a period of time, the previous meter reading is subtracted from the current one.

Cost calculations will vary depending on whether a sliding scale or fixed rate is used, but the basic calculation involves multiplying the rates charged by the amount of electricity used.

For example, suppose that last month's meter reading was 2,000 kilowatt-hours. This month's is 3,511 kilowatt-hours. Using the sliding rate scale given below, what would the cost be?

Sliding rate scale:

\$.08 for the first 100 kWh
\$.07 for the next 200 kWh
\$.06 for the next 300 kWh
\$.05 for the next 500 kWh
\$.04 for over 1,100 kWh

Total kilowatt-hours consumed:

3511 kWh - 2000 kWh = 1,511 kWh

- The third dial is read counterclockwise.
- The fourth dial is read clockwise.

Cost:

First 100 kWh \times \$.08 = \$8.00
Next 200 kWh \times \$.07 = \$14.00
Next 300 kWh \times \$.06 = \$18.00
Next 500 kWh \times \$.05 = \$25.00

1,511 kWh - 1,100 kWh = 411 kWh
411 kWh \times \$.04 = \$16.44

Total cost:

\$8.00 + \$14.00 + \$18.00 + \$25.00 +
\$16.44 = \$81.44

Summary

The power equation and Ohm's Law measure the flow of electricity through an electrical system.

They make it possible to calculate loads for each structure, check electrical costs, and plan for future expansion to meet electrical needs. When the electrical system is in use, the amount of electricity used can be calculated by reading the watt-hour meter. This information can be used to determine the cost of electricity.

Credits

Holzman, H.N. *Modern Residential Wiring*. South Holland, Ill.: Goodheart-Willcox Company, Inc., 1986.

Richter, H.P., and W. C. Schwann. *Wiring Simplified*. 38th ed. Somerset, Wis.: Park Publishing, Inc., 1996.

Lesson 11: Lightning Protection

Lesson 11: Lightning Protection

Lightning strikes the earth 100 times per second every day. In the United States, more than 125 people are killed by lightning each year, not including fatalities from fires related to lightning. Lightning damage also affects electrical systems.

In areas where lightning occurs frequently, a properly installed lightning protection system is necessary.

Why Lightning Strikes

Lightning is the visible discharge of static electricity. This discharge can occur within a cloud, between clouds, or between the earth and a cloud. Basically, lightning is a large electric spark caused when current jumps a gap in the air.

Strikes occur when hot and cold air masses meet, causing atoms to lose electrons. Once freed, negatively charged electrons gather at the A lightning protection system provides a path for lightning to the ground that is an alternative to traveling through a building or equipment. It prevents damage to structures and keeps people and livestock from being injured. It does not directly attract lightning or prevent a lightning strike. Proper planning is essential in developing a lightning protection system that will efficiently protect people and property.

Before installing lightning protection, the need for such protection should be assessed. The

cloud base. Positive ions converge at high locations on the earth's surface, such as hilltops, silos, buildings, and trees, as illustrated in Figure 11.1. The ions and electrons are attracted to each other, creating a stepped leader, which is an unseen conduit through which negative charges move from the cloud to the earth. From the earth, ion streamers called leaders travel upward. If the two puncture the air gap insulator and converge, a channel is created for electrical energy to move between the earth and the cloud as the charges rapidly equalize themselves.

The average lightning bolt lasts from 1/1000 to 1/10 of a second and can produce temperatures up to 50,000 degrees Fahrenheit. It can create 1 million volts of electricity. Therefore, lightning protection is necessary for protection from fires and electrical surges.

The Need for Lightning Protection

National Fire Protection Association has published a risk assessment guide in their Lightning Protection Code, while insurance companies may also provide assistance in assessing the risk of damage from lightning. Factors considered include the frequency of lightning, the type of structure and its construction, the location of the structure, the topography of the surrounding area, and the contents of the structure.

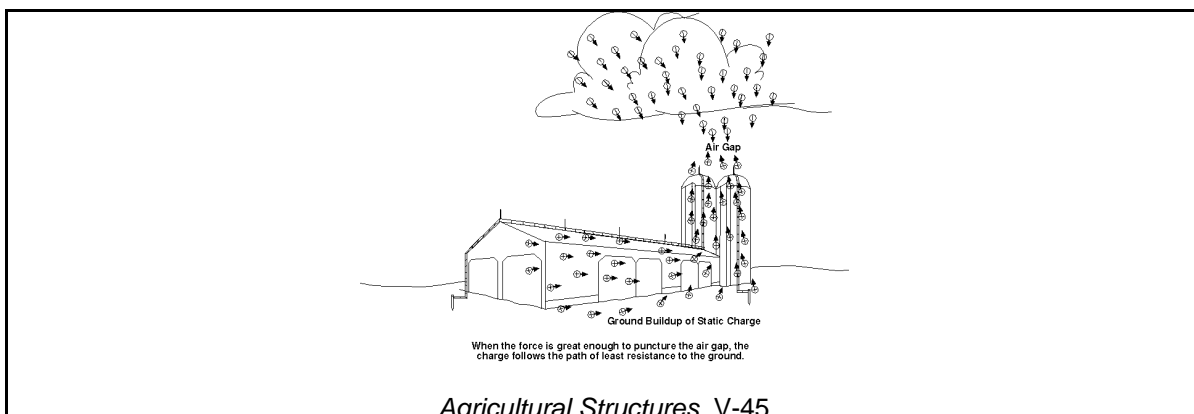

Electricity

In addition to these factors, a few other considerations exist for agricultural operations. Tall structures such as silos should be grounded not only to protect them but because they can provide a cone of protection with a diameter that is two times the height of the object. This cone can protect other structures that fall within it. Also, like buildings, electric fences should be grounded.

A Good System of Protection

A good lightning protection system has some basic components shown in Figure 11.2. Air terminals, or lightning rods, are the points where lightning strikes. Air terminals need to be installed on high points on structures, such as roof ridges or ventilators. The main conductors

Installing the Lightning Protection System

Proper installation is crucial to an efficient lightning protection system. Most insurance companies follow the guidelines described when they inspect the system to see if it is acceptable.

A qualified professional should install the lightning protection system to make sure the proper procedures are followed.

are the cables that connect the air terminals to the grounding electrodes, or ground terminations.

The ground terminations are copper or copper-clad rods driven into the earth, preferably to a minimum of ten feet in depth. Lightning arresters are used to protect electrical wiring from lightning-induced damage. They are installed at the service entrance. Surge suppressors are used to further protect electrical equipment, such as computers. They are typically small boxes into which electrical equipment is plugged. Arresters and suppressors work by breaking the electrical circuit when an overload is present. These devices handle any residual current that may leak through the main lightning protection system.

Some general design rules apply to all lightning protection systems. These rules affect the number of grounding electrodes and the number of grounding cables. All buildings with a perimeter of 250 feet or less must have two grounding electrodes, preferably diagonally at opposite corners of the structure. If the perimeter is between 250 and 350 feet, three electrodes are required. At perimeters of 350 to 450 feet, four

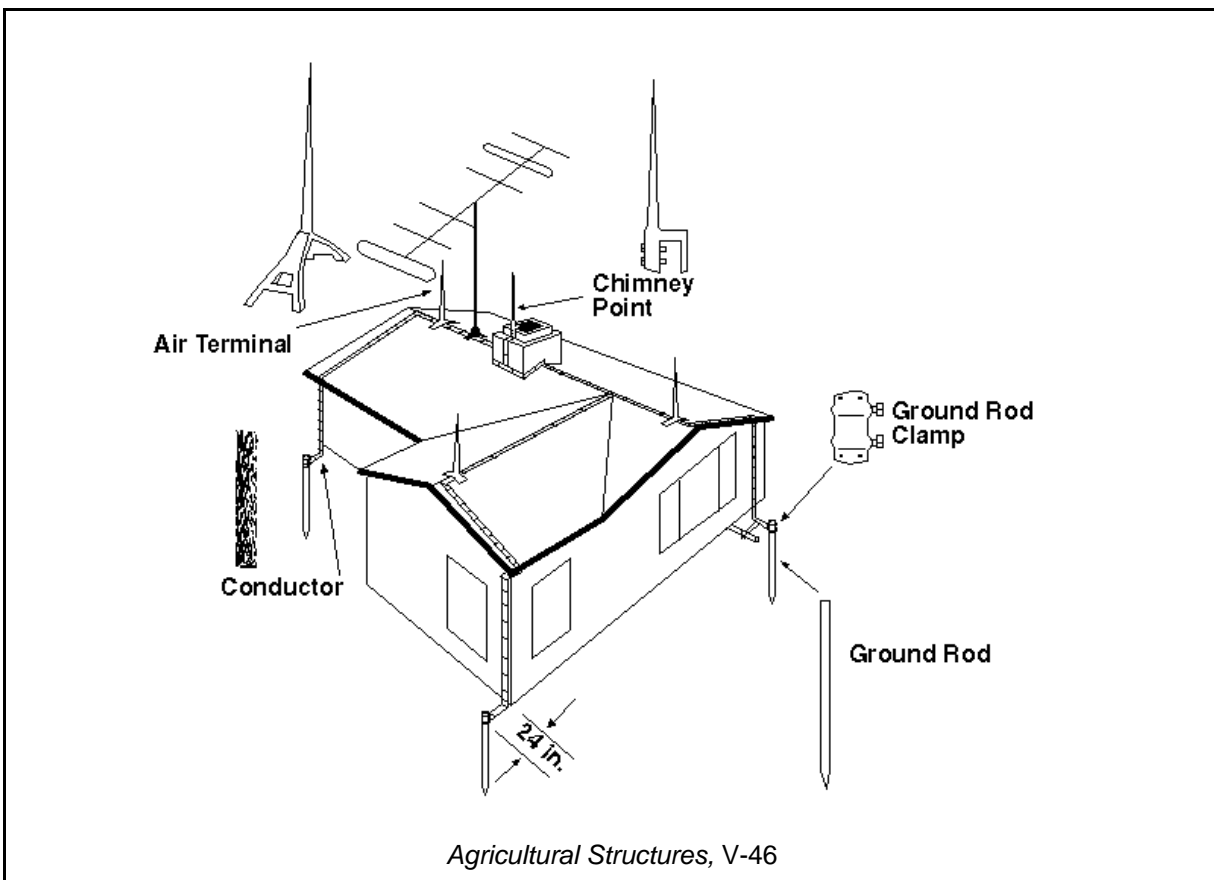

Lesson 11: Lightning Protection

electrodes are necessary. As the perimeter increases, another grounding electrode is added for every 100 feet of perimeter. Also, the grounding conductors should follow a straight horizontal or vertical path to the grounding electrode. The cables need to be free of sharp turns and “U” or “V” pockets, which are sharp kinks or small bends in the cable. Turns in conductors should not exceed 90 degrees, and bends should not have a radius of less than eight inches. Sharper bends can restrict the flow of electricity.

Certain guidelines must be met when installing a lightning protection system. For proper protection, air terminals should be properly sized, spaced, and installed to receive lightning strikes.

The down conductors, which are the vertical conductors that are attached to the ground rods, should carry the discharge directly to the ground.

Entrance conduits, gutters, drain pipes, pipe vents, metal water pipes, radio and T.V. antennas, metal roofing, fences, and other metal objects should be bonded or connected to the down conductors and ground rods. The main bonding conductors must be at least AWG 6 copper wire or its equivalent. Down conductors should be enclosed in a conduit or metal tubing. The conduit should extend from a point at least five feet above ground level to one foot below the ground's surface to provide protection against physical damage.

Ground rods of adequate size must be located properly throughout the system. Lightning system ground rods must be driven to a minimum depth of 10 feet where soil conditions permit. If grounding electrodes cannot be driven to this depth, other acceptable options are to dig a trench 3 to 4 feet deep by 10 feet long and bury a grounding rod or to bury a grounding plate at least 18 inches deep. Another method of grounding involves connecting down conductors to a metallic water system, as long as Lightning or surge arresters are used to remove high voltage charges from the system by breaking the circuit and then diverting the electricity to the ground. These devices act as a safety valve, draining power surges out of the system. They are installed where service wires enter the building at the service entrance panel or prior to the connection of specialized electrical loads, such as submersible water pumps or feed handling equipment, or other equipment away from protected buildings.

as the pipes are a minimum of three feet deep and ten feet long and are in direct contact with the earth. If ground rods used for the electrical or telephone system are within 6 feet of a grounding electrode for the lightning protection system, they must be bonded together to prevent side flashes, or the arcing of electricity between conductors. Side flashes can lead to fires, physical damage, and power surges to other electrical systems.

Protecting Equipment from Lightning

Protecting equipment is another important reason to install lightning protection. Overloads can cause tremendous damage to electrical systems and equipment. The power supply system has built-in lightning protection. A number of devices are also used to protect individual pieces of equipment from lightning.

The power supply system itself serves as protection from lightning. As power comes from the source, it passes through several transformers and other devices that reduce and convert the electricity into forms the consumer can use. This process is referred to as “stepping down.” Lightning protection is offered at each level.

Surge suppressors, as discussed previously, are used to protect electronic equipment, particularly computers, from surges or spikes of electrical current. These devices provide a receptacle or a bank of receptacles with a breaker that automatically trips when the electricity spikes. If computer equipment is plugged into telephone lines, the lines also require surge suppressors to prevent damage from lightning. Telephone companies place lightning suppression devices in the lines. Special surge suppressors have connections for telephone lines.

Controllers are another type of device that helps protect electrical equipment from lightning. All motors must have some type of controller, which is normally used for starting and stopping the motors. For small motors of $\frac{1}{2}$ hp or less, the overcurrent device at the service entrance panel is sufficient to act as a controller. However, for larger motors, a separate switch with a current capacity at least twice the full load rating of the motor is required. The controller should have

Electricity

overload devices installed that stop the current to the motor during electrical surges and power overloads. These devices should also have a manual reset so the motor does not restart automatically when normal power is restored.

Grounding Lightning off a Structure

The grounding of the lightning protection system will determine the extent of protection available. Grounding consists of connecting one end of a properly sized copper conductor to the air terminals and the other end to a metal conductor that is in direct and permanent contact with the earth, as shown in Figure 11.3. A ½-inch copper rod, a ½-inch copper-clad rod, a ¾-inch galvanized iron pipe, or a metallic water system should be used for grounding. If a ground rod cannot be used due to rock beneath the soil, a When installing the grounding system, the wire is clamped to the grounding electrode using lugs or clamps. A steel strap or solder should not be used to attach wires because these methods are structurally weak and may not provide the contact needed during a lightning strike.

Summary

An efficient lightning protection system is necessary to help prevent damage to buildings

and equipment and loss of life. The system should consist of properly sized and placed air terminals, down conductors, bonding conductors, and grounding electrodes. It should also include protection for equipment, such as surge suppressors, arresters, and controllers. It is highly recommended that a qualified and certified professional install this system for the home and farm.

Table 11.1 - Wire Sizes

Service Entrance Wire Size	Copper Ground Wire Size
Up to AWG 2	AWG 8
AWG 1 or 0	AWG 6
AWG 00 or 000	AWG 4
AWG 0000 or larger	AWG 2

and equipment and loss of life. The system should consist of properly sized and placed air terminals, down conductors, bonding conductors, and grounding electrodes. It should also include protection for equipment, such as surge suppressors, arresters, and controllers. It is highly recommended that a qualified and certified professional install this system for the home and farm.

Credits

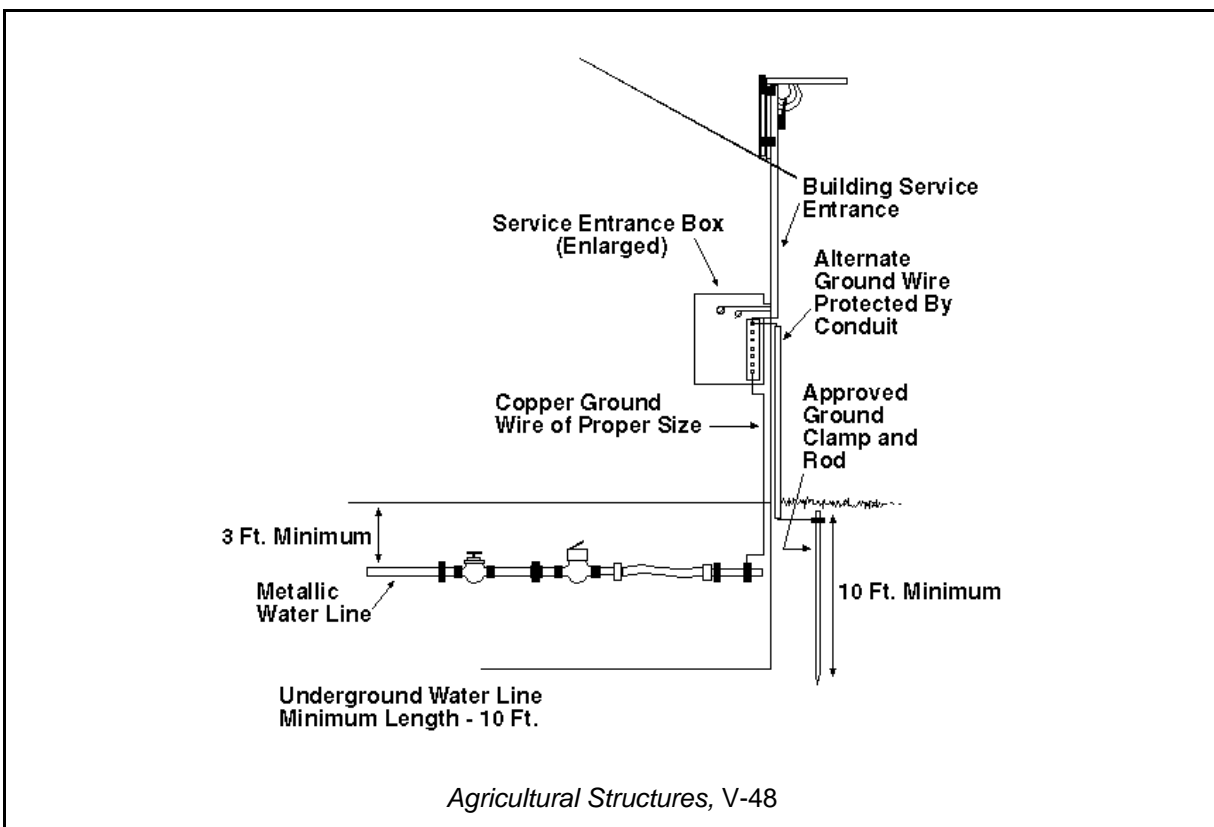

Lesson 11: *Lightning Protection*

Electricians Toolbox Etc. "Lightning Protection."

<http://www.elec-toolbox.com/usefulinfo/lightprot.htm> (8 Feb. 1999).

Holzman, H.N. *Modern Residential Wiring*. South Holland, Ill.: Goodheart-Willcox Company, Inc., 1986.

Lightning Protection for Missouri Farms and Homes (G1020). University Extension agricultural publications, 1993.

Richter, H.P., and W.C. Schwann. *Wiring Simplified*. 38th ed. Somerset, Wis.: Park Publishing, Inc., 1996.

State Farm Educational Materials. "Lightning Protection." <http://www5.statefarm.com/educate/lightnin.htm> (8 Feb. 1999).

Lesson 12: Detecting Problems

After installation, problems may arise in the electrical system. These problems can be the result of improper wiring, misuse, or just wear on equipment. When problems occur, detecting what the problem is and correcting it is important.

Investigating the nature of the problem may require the use of different testing devices.

Testers Used in Troubleshooting

A variety of meters and testers can test electrical systems. Three of the more common are the neon tester, the voltage tester, and the VOM meter. Figure 12.1 shows examples of these testing devices.

The neon tester is the simplest device used by electricians. This tester can be used on either a 120-volt or 240-volt system. A glowing light indicates that voltage is present in a circuit. The greater the voltage in the circuit, the brighter the light glows.

A voltage tester is used to indicate the voltage and polarity, or direction of electrical flow, in a circuit. The tester uses a series of neon lights. A neon tester is commonly used for testing outlet receptacles. It has two leads attached to the

to indicate the approximate voltage moving through the circuit.

Another type of tester is a VOM meter. VOM stands for volt-ohm-milliammeter. This tester supplies the same information as the others, displaying the voltage and polarity of the circuit. It also provides accurate measurements of circuit resistance and amperage. To provide this information, this testing device combines a voltmeter, ohmmeter, and ammeter in one casing. The voltmeter measures the voltage across two points in an electrical circuit. The ohmmeter measures resistance, and the ammeter measures the electrical flow or amperage. The VOM meter provides this information on a calibrated numerical scale.

Using Testing Devices

To safely determine what type of electrical problem exists, it is important to know how to use testing devices properly. All testers come with manufacturer's directions for their use. These instructions should be read prior to using any type of testing device.

tester. To use a neon tester to test a receptacle, the ends of the leads are placed into the parallel

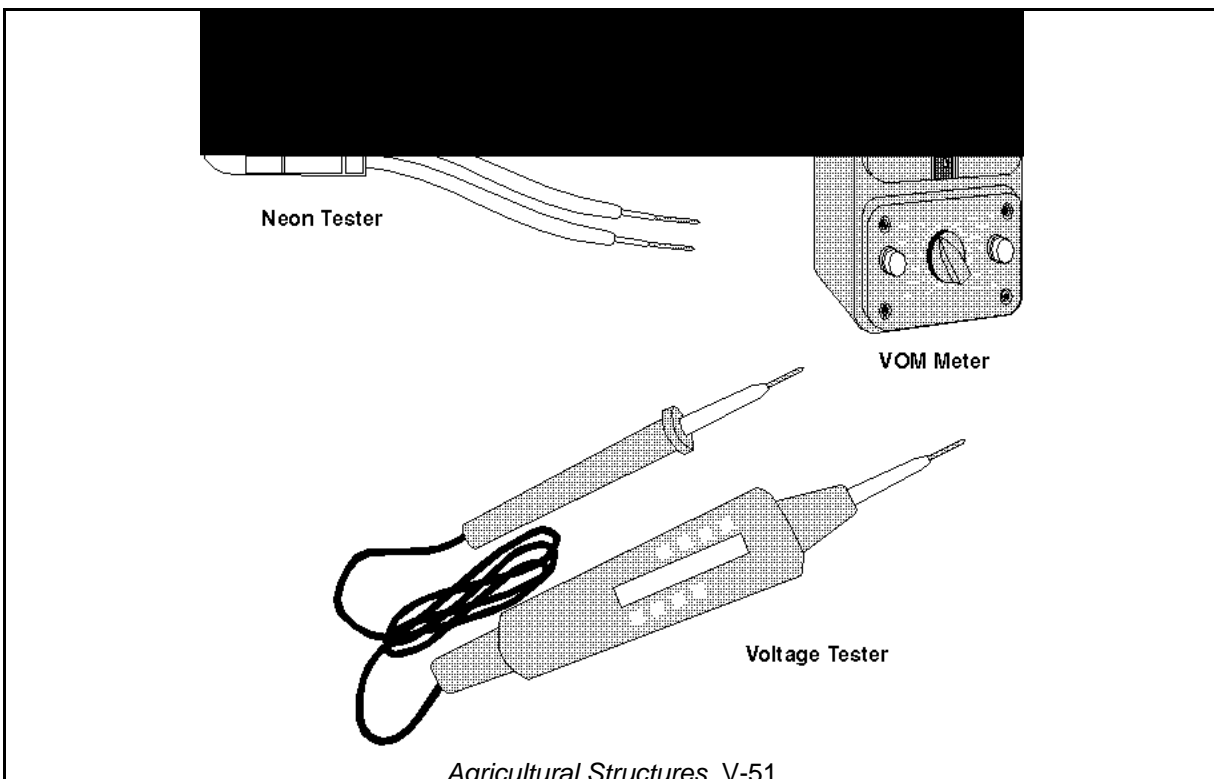

Electricity

slot openings. If the tester lights up, no problem exists. If the tester does not light up, the end of one of the leads is inserted into the ground opening, with the other lead in one of the other slots. If the tester lights up, the problem is with the neutral connection or the neutral wire, which is not allowing electricity to flow beyond the receptacle. However, if the tester still does not glow, the outlet cover plate and receptacle are removed. The leads are then touched to the opposite terminal screws. If the tester lights up, the receptacle does not function and should be replaced.

The voltage tester can test outlets, switches, fixtures, and other electrical devices. Like the neon tester, it has two leads attached to the tester housing. It works in a similar way. However, the voltage tester also indicates whether an electrical system carries 120 volts or 240 volts as well as the polarity of the system.

A VOM meter is similar to the other testers in that it has two leads. However, the leads are color coded, with red used for the power side and black for return or neutral side of the circuit during testing. The leads are used as they are with the other testers; for example, to test a switch, the leads are connected to the terminals of the switch after the cover plate is removed.

Some special considerations exist when using the ohmmeter portion of the meter. The ohmmeter contains its own power source, so all power to the electrical system should be disconnected before testing for circuit resistance.

If the power is not shut off, damage to the meter will occur.

Summary

Three types of testers are commonly used when examining electrical systems for problems. They are neon testers, voltage testers, and VOM meters. To properly troubleshoot the electrical system, it is important to be competent in the use of the various testing devices. Before using any testing device, carefully read all the manufacturer's instructions to avoid problems.

Credits

Holzman, H.N. *Modern Residential Wiring*. South Holland, Ill.: Goodheart-Willcox Company, Inc., 1986.

Richter, H.P., and W.C. Schwann. *Wiring Simplified*. 38th ed. Somerset, Wis.: Park Publishing, Inc., 1996.

Lesson 1: *Electrical Safety*

Electricity is all around people every day. It lights their homes and workplaces, keeps them warm and cool, and cooks their food. Electricity is also a major energy source utilized in agriculture. While electricity is a helpful tool, it can be a hazard if not respected. Estimates from the National Electrical Safety Foundation indicate that the electrical systems in homes were involved in 43,000 fires, 330 deaths, and 1,720 injuries in 1993. In 1992, their data shows an estimated 530 electrocution deaths.

Basic Rules of Electrical Safety

Electrical safety is a major consideration in the home and in agricultural operations. In electrical safety, the primary focus is on two main concerns: shock and fire. Anyone who has ever touched an electric fence has felt the effects of an electric shock, which is the passing of an electric current through the body and the body's reaction to it. An electric shock will affect the rhythm of the heart, possibly leading to serious injury or death.

Everyone is familiar with fires, but an electrical fire generally begins unnoticed. Electrical fires have two main causes. Some fires begin because wires overheat. This situation generally occurs when a restriction exists in the flow of electricity through the conductor or if a system is overloaded. The second way electrical fires begin is with an electrical current jumping a gap, creating sparks. Broken wires or improper electrical connections may produce a gap.

How can these hazards be reduced? Anyone working around or using electricity must take note of a number of precautions. During the installation and repair of electrical systems, the main power source should always be disconnected before working with the system. Also, state and local electrical codes should be followed when installing new systems. Manufacturers' instructions for the installation and use of electrical equipment are another important source of information about the proper procedures to use. Short cuts during installation can lead to hazards later.

As with most hazardous situations, misuse due to the human factor tends to be the single

The use of extension cords is another factor that can create electrical hazards. Extension cords are not a permanent fix for a lack of wall outlets. Cords should only be used for a short period when the cords on electrical equipment do not reach an outlet. Extension cords should not be placed under items, such as rugs or other things that put weight directly onto the cord. Placing them in high traffic areas can also lead to insulation damage and a restriction of electrical flow and should be avoided. A long extension cord should always be uncoiled before plugging it in. A coiled conductor creates greater resistance to electrical flow, which can lead to voltage loss, blown circuits, and fire hazards. If an extension cord becomes warm or smells of burning rubber, its use should be discontinued immediately.

Fuses and breakers, which are safety devices designed to shut off electrical flow, can be a source of electrical hazards. Activation of a fuse or breaker device is an indication that a problem exists with the electrical system. The problem may be an electrical overload, with too many items running on a system, or something more serious within the electrical circuit. Checking out the system and correcting the problem is important before replacing the fuse or resetting the breaker. A higher capacity fuse or circuit breaker should never be used for a repair.

Electrical systems are designed to carry a certain load, and an attempt to increase this load will burn out the system.

A situation that can be extremely hazardous, and one in which agricultural electricians often find themselves, is performing an installation near wet areas. Water is an excellent conductor of electricity, and if electricians are working on a system or using a tool in a damp environment, they can become a conductor for the electrical flow as it seeks a ground. While working with electrical systems or appliances in areas that are wet or damp, making sure that the power is disconnected is important. Cabinets, shelves, and stands should be utilized to keep tools and appliances dry. GFCI outlets, special outlets designed to interrupt electrical flow in hazardous situations, in noncorrosive plastic device boxes should be installed in wet or damp areas.

greatest cause of electrical mishaps. Electricity, although beneficial, can cause large amounts of

Electricity

property damage and lead to loss of life, so following suggestions for safe installation and use of electrical systems is vital. When working with electricity, remember that safety devices put in place by manufacturers have a purpose and do not damage or disable them. Do not use any electrical product that is damaged in any way. Do not remove a plug from an outlet by pulling on a cord, and never carry a power tool by its cord.

Joining two wires that are composed of different metals can pose a hazard. They can create a fire hazard. A special type of connector should be used to prevent problems.

Sources of Electrical Defects in Equipment

Defects that occur in electrical equipment have six common sources. They are problems with the ground wire, open conduits, damage to the insulation, damage to equipment, lack of maintenance, and misuse.

Ground wire defects occur when the ground, or neutral, wire is missing, broken, improperly connected, or not connected at all. These problems can lead to shorts in the system and a possible shock hazard to anyone using equipment connected to the line.

Conduits are metal or plastic tubes that enclose electrical wires. Open conduits are defects that lead to wire damage. When a conduit is left open, damage may occur from water entering the conduit. Open conduits also allow for wear and deterioration of the insulation. This type of defect can create a short circuit.

Insulation damage occurs when the insulation becomes worn, wet, or oily. Damaged insulation can lead to short circuits, shocks, and fire hazards.

Another source of defects is damage to equipment that occurs during manufacturing or installation and use. Defects normally occur in switches, receptacles, and extension and appliance cords. This type of defect can lead to shock and fire hazards.

Poor equipment condition may be caused by a lack of maintenance. Dirty, improperly adjusted electrical equipment can overheat, throw sparks,

and short out. Poor maintenance can also create a fire hazard.

The most common source of defects is misuse through carelessness. Carelessness may result in the misuse of equipment, improper wiring practices, limited knowledge of electrical systems, and working around electricity in wet environments without proper precautions.

Electrical Injuries

Electrical injuries can occur anywhere a source of electricity is present. Coming in contact with an electrical source can send a current of electricity through the body. The amount of current will depend on the degree and quality of the insulation on the electrical source and the electrical resistance of the skin. Skin resistance is at its lowest when the skin is damp or if the location is wet. In this situation, a current of .006 amps can electrocute a healthy individual in less than one second.

What should be done if someone gets shocked?

For someone receiving an electric shock of 120 to 240 volts, the first step is to disconnect the source of the electric current, if possible. If it cannot be disconnected, a long pole or other item of nonconductive material, such as wood or fiberglass, is needed. The person holding the pole should insulate himself or herself by making sure to avoid any liquids or wet areas and then use the pole to move the person or the conductor, depending on which is easier and safer to move.

If the power source is over 240 volts, as is the case with overhead wires, anyone in the area should assume that the downed wire is live and can kill. Everyone should be kept at least 200 feet away because the static electricity in the air can arc to individuals wearing any type of metal.

Rather than trying to help the victim themselves, they should contact emergency personnel immediately and call the power company to give them the exact location of the incident.

In either case, rescuers should never attempt to grab a person in direct contact with a live wire. The electrical current will "freeze" muscles, thus compounding the situation and putting the rescuer at risk of electrocution and death.

First aid should be given once the victim is removed from the electrical source. Rescuers should check to see if she or he is conscious and then check for signs of breathing and a pulse. If they are trained in the use of CPR, they should perform CPR on the victim until emergency personnel can arrive. Victims of electrical shock often suffer burns. If burns are present, they should be covered with a dry, sterile dressing. Rescuers should not attempt to cool electrical burns since efforts to soothe them may only make the situation worse and can lead to further damage. Finally, the victim should never be moved unless an immediate threat to his or her safety exists. Due to the nature of an electrical injury, the victim may experience damage to the spine that would be worsened by being moved.

Types of Circuit Protection

An overcurrent device limits the amperage in any wire to the maximum permitted. Fuses and circuit breakers are overcurrent devices. Both of these devices are rated by the number of amps that will travel through the overcurrent device without triggering it. The size of the wire used in the system will determine the amperage rating of the overcurrent device used. Different types of overcurrent devices are shown in Figure

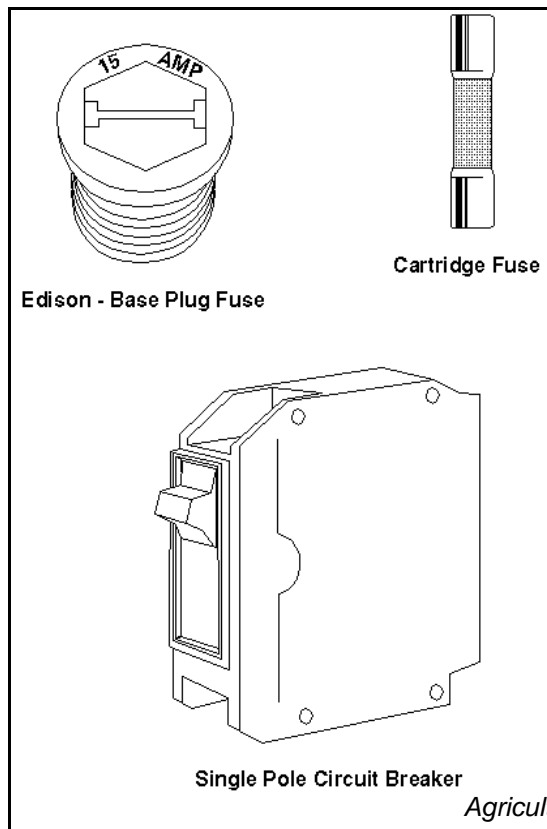

1.1.

A fuse is a short piece of metal that has been experimentally tested to melt at a predetermined flow of amps. This piece of metal is housed in a nonconductive material for the purposes of protection and removal. The most common type of fuse is the plug type, which screws into the electrical service panel, the box located where power enters the building. If a fuse blows, it should be replaced with one of equal amperage, never with one of higher amperage.

The circuit breaker is a semi-permanent device positioned in the service panel during wire circuit installation. This device does not require replacement when a break occurs in the circuit. The circuit breaker resembles a toggle switch with a handle. It has four switch positions: on, tripped, off, and reset. Inside the circuit breaker is a mechanism that "trips" the breaker and disconnects the load in an overload situation. Because of the ease of resetting a circuit breaker, this overcurrent device is the type most commonly used.

Fuses and circuit breakers normally provide sufficient protection for electrical equipment. However, they do not always entirely protect people from being shocked. Therefore, ground fault circuit interrupters (GFCI) should be used in certain situations. They interrupt the flow of electricity in order to prevent electrical shock if a fault exists in the circuit that will not affect a fuse or circuit breaker. GFCIs will be discussed in more detail in Lesson 4 of this unit.

Summary

Electrical safety concerns everyone. Being aware of electrical hazards will enable an individual to safely work with electricity. He or she must understand the safety devices needed and know what to do in an electrical emergency.

Credits

Consumer Information Center. "A Home Electrical Safety Check." From the National Electrical Safety Foundation, 1995. http://www.pueblo.gsa.gov/cic_text/housing/home-elec/homeelec.txt (1 Sept. 1998).

Electricity

Cooper, Elmer L. *Agricultural Mechanics: Fundamentals and Applications*. 2nd ed. Albany, N.Y.: Delmar Publishers, 1996.

Holzman, H.N. *Modern Residential Wiring*. South Holland, Ill.: Goodheart-Willcox Company, Inc., 1986.

Huth, Mark W. *Construction Technology*. 2nd ed. Albany, N.Y.: Delmar Publishers, 1989.

Phipps, Lloyd J., and Carl L. Reynolds. *Mechanics in Agriculture*. 4th ed. Danville, Ill.: Interstate Publishers, 1990.

Lesson 2: Electrical Terminology

Power line installer and repairer
Power line troubleshooters
Cable splicer
Construction electrician
Maintenance electrician

Lesson 2: Electrical Terminology

In addition to safety practices, anyone working with electricity needs to understand the basic terminology associated with it. Without a knowledge of these basics, it is impossible to work with electricity effectively.

Terms and Definitions for Electricity

In every occupation, including those that require working with electrical systems, terms and definitions exist that an individual must learn to be competent in that field. This terminology includes the names of devices used in electrical systems, types of current, units of measurement, and common problems in electrical systems.

A typical electrical system contains a number of components. The conductors are the wires through which the electrical current is carried through a circuit, which is the complete, uninterrupted path of electricity. Most conductors are made from copper, aluminum, or copper-clad aluminum. In the system are positive, or hot, wires that act as the conductors of electrical power. The insulation on these wires is typically color-coded red or black. The other wires, which are called neutral wires, conduct electricity from the appliance back to the source, completing the electrical circuit. These wires are color-coded white or gray. Insulation made of plastic or rubber forms the protective covering on the wires. All electrical systems should be grounded to function safely. Grounding is the electrical connection from the appliance or piece of equipment to the earth.

The system also contains circuit protection devices in the form of fuses or circuit breakers. The fuse is a safety device that prevents the overload of an electrical circuit by “burning out” and interrupting the electrical flow. A circuit breaker is an automatic flip switch located on an electrical circuit that breaks, or shuts off, the current when overloaded.

An electrical system may use one of two types of current. Alternating current (AC) is the most In 1911, the National Fire Protection Association (NFPA) sponsored the development of the National Electrical Code (NEC). The goal of the NEC is to address four issues: changing power needs in the United States, safe user practices

common type of electricity supplied to the home or farm. The electrical current alternates, or changes its direction of flow at regular intervals, usually 60 times per second. Direct current (DC) is electrical current that flows steadily in one direction through a conductor, either from the positive pole to the negative or from the negative to the positive. A generator or battery produces direct current.

The three major units of measurement in electricity are amperage, voltage, and wattage. Amperage is a measurement of the flow of current through an electrical system; it is measured in amperes, or amps (A). Voltage is the measurement of the pressure created by electricity moving through the conductor. It is measured in volts (V). Wattage is the measurement of the total electrical power within a system. Wattage is calculated by multiplying amperage and voltage and is measured in watts (W). A term most people are familiar with is kilowatt (kW), which is 1,000 watts. Electrical meters read electricity in kilowatt hours, which is the use of 1,000 watts of electricity in one hour. Another important measurement is resistance. Resistance, which is measured in ohms, is the opposition to the flow of current as it moves through a conductor.

Two common problems that occur in electrical systems are voltage drops and short circuits. Voltage drop is the loss of electrical pressure from the source to the point of use. This problem normally occurs in overload situations. Short circuits occur when wires in the same circuit come into contact, causing the flow of electrical current to move from its desired path. Worn insulation or loose connections at the appliance or piece of equipment may cause a short circuit.

The National Electrical Code (NEC)

of new technology, minimum standards for electric wiring practices and materials used nationwide, and increased energy use in the home, workplace, and community. The electrical code is printed periodically in book

Electricity

form. Topics covered in the 1996 edition include: wiring and protection, wiring methods and materials, equipment for general use, special occupancies, which are buildings for particular purposes, special equipment, special conditions, and communication systems. Revisions to the NEC are done under the supervision of the NFPA and identify new issues and technologies related to electrical installations.

Enforcement of NEC Guidelines

The NEC is basically a reference and resource for state and local governments and for insurance companies. Government agencies utilizing the NEC include the Occupational Safety and Health Administration (OSHA) and state and local building inspectors. Insurance companies may require the use of NEC guidelines in buildings they insure, primarily for those structures being built for rental or resale. Through these entities, the regulations found in the NEC handbooks are enforced.

UL Listings

The Underwriters Laboratories, Inc. (UL) is an independent, not-for-profit testing and certification organization that evaluates products, materials, and systems, such as electrical outlets and appliances, in the interest of public safety. The UL has been functioning in this capacity for over a century.

A UL listing means that representative samples of the product have been tested and evaluated with reference to nationally recognized safety standards for electric shock, fire, and related safety hazards. A UL listing is important because it provides a degree of product quality assurance, which is vital when dealing with an item that has the potential of being a fire or shock hazard.

Summary

Certain terms are very important to know in order to understand electricity. Knowing these terms will help to understand the concepts relating to electricity and how it works. Individuals working with electricity must also understand and utilize those practices outlined in the NEC. Products with a UL listing are useful because their quality has been assured.

Credits

Cooper, Elmer L. *Agricultural Mechanics: Fundamentals and Applications*. 2nd ed. Albany, N.Y.: Delmar Publishers, 1996.

Huth, Mark W. *Construction Technology*. 2nd ed. Albany, N.Y.: Delmar Publishers, 1989.

Phipps, Lloyd J., and Carl L. Reynolds. *Mechanics in Agriculture*. 4th ed. Danville, Ill.: Interstate Publishers, 1990.

Lesson 3: Wire Types and Uses

The size and type of wire used for wiring are among the most important considerations in electrical installation. Different types of wire may be used, depending on the type of structure, its uses, and the electrical load of the circuits.

Wire Types

Traditionally, electrical wire has been made from copper or aluminum. However, copper wire is the best conductor for most purposes. It is also the most widely used type of wire. Compared to copper, aluminum is a relatively poor conductor, and copper-clad aluminum is only slightly better. Aluminum wire must be two sizes bigger than copper wire would be to produce similar results.

Three categories of electrical wiring are typically used: service wires, interior wires, and cables. Service wires carry power into the home or building to the service entrance panel. The wires are either SE wires for overhead installations or USE wires for underground service. Service wires consist of a bundle of wires, with fine strands of uninsulated wire wrapped around the insulated wires, as shown in Figure 3.1. The uninsulated wire is the grounded neutral.

Interior wires, which are wires that must be protected from the elements, can be divided into two categories, Type T and Type R. Type T is The three categories of Type R wires are RH, RHH, and RHW. RH wire is designed for dry conditions and a maximum temperature of 167 degrees Fahrenheit. RHH is also designed for dry conditions but has a higher temperature rating of 194 degrees Fahrenheit. RHW wire will work in either wet or dry conditions and has a temperature rating of 167 degrees Fahrenheit.

Cables form another category of electrical wire. To make a cable, individual wires are assembled and covered with a protective element. Cable is

the most commonly used interior wire type. This wire has thermoplastic insulation, which is a single layer of plastic compound that covers the individual wire. The insulation strips off easily and cleanly, making the wire easy to use. Type R wire was previously rubber coated for insulation, but advances in synthetic polymers have led to the use of these substances instead.

This type of wire may also have a moisture-resistant, flame-retardant outer covering. Type R wires are rarely used in modern construction, although they are still found in many older structures.

Based on the wire's ability to withstand environmental and temperature conditions, Type T wires are divided into four categories: TW, THW, THHN, and THHW. TW wire is moisture resistant. However, the wire may not be buried directly in the ground. The insulation can withstand a maximum temperature of 140 degrees Fahrenheit. THW wire is considered to be both moisture and heat resistant. Its insulation has a heat rating of 194 degrees Fahrenheit. Like TW wire, it may not be buried in the ground. The insulation of THHN wire can also withstand a maximum temperature of 194 degrees Fahrenheit, but it may be used only under dry conditions. THHW wire, on the other hand, is designed for wet or dry conditions, with insulation that can handle a maximum temperature of 194 degrees Fahrenheit in dry conditions and 167 degrees Fahrenheit in wet conditions.

the predominant form of structural wiring used in the modern construction industry. The NEC has developed a set of identification requirements that indicate the information that must be present on the cable, as illustrated in Figure 3.2. This information includes the following elements.

- Size of the wires
- Insulation type
- Voltage rating
- Testing agency

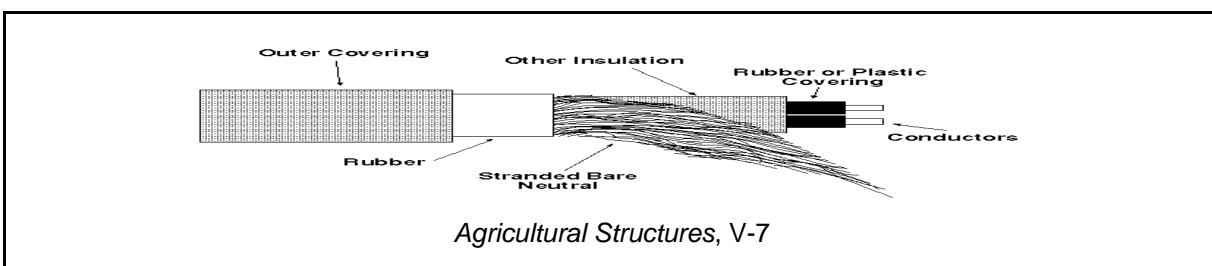

Electricity

- Number of conductors
- Outer finish or covering

The three main types of cables are nonmetallic sheathed cable, armored cable, and flexible cord.

Nonmetallic sheathed cable is the most common type of cable used in building construction. It typically contains two or three THHN or THHW wires with an additional bare ground wire. This cable is easy to install, clean in appearance, and highly economical. Nonmetallic sheathed cable comes in three forms: NM, NMC, and UF. NM is used in dry conditions and not in barns or other damp locations on agricultural operations. NMC is designed for damp or corrosive locations but cannot be buried underground. UF, or underground feeder, is identical to NMC but can be buried directly underground.

Another type of cable is armored cable. This cable is used in dry locations only. It normally Agricultural structures pose slightly different requirements than homes and businesses in terms of electrical work and wiring. Section 547 of the NEC describes the basic criteria. The NEC addresses two main categories of agricultural buildings. In the first category are buildings where excessive dust and dust with water may accumulate. Such buildings include totally enclosed and environmentally controlled poultry and livestock structures, confinement

contains TW, THW, or THHN wires. The individual wires are enclosed in a tough paper overwrap and spiral steel armor.

The third type of cable is flexible cord, which connects electrical devices to outlets. Various types of flexible cord are available. Types SPT-2 and S are used for connecting lamps, appliances, and other devices to outlets. Type SPT-2 has wires imbedded in plastic and is used for small appliances, such as lamps and radios. Type S is heavier and is used for applications where heavy use and abuse is possible, such as for power tools. The wires are bundled into a round assembly insulated with plastic or rubber. Another type of flexible cord is HPN, or heater cord. This type of cord is used with heating appliances, such as toasters and irons.

Wires for Agricultural Wiring

systems where litter, dust, and feed dust may accumulate, and feed mills. The second category consists of buildings with a corrosive atmosphere. These structures include totally enclosed and environmentally controlled areas where poultry and animal excrement may cause corrosive vapors in the confinement area, where corrosive particles may combine with water, or where the area is damp and wet because of periodic washing and sanitizing.

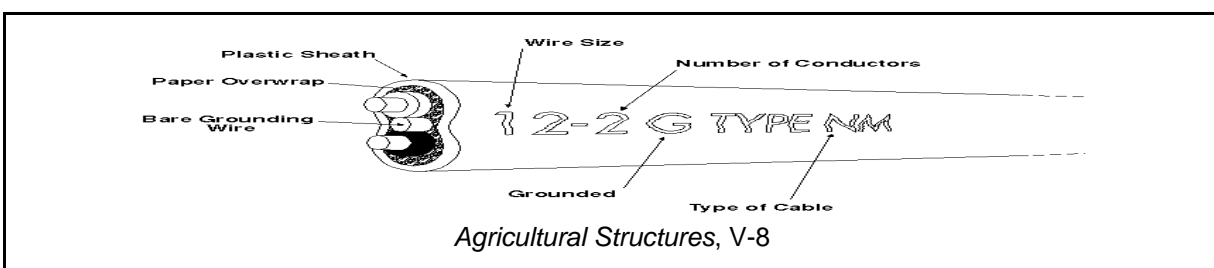

Lesson 3: Wire Types and Uses

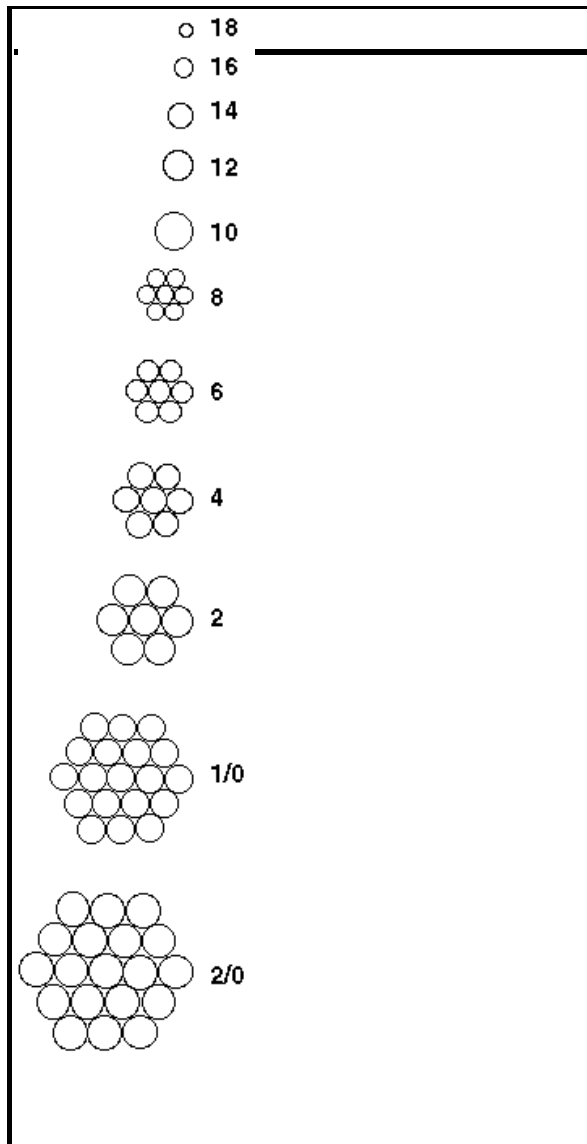

dust fires and explosions. Therefore, wires and fixtures should not produce arcs, sparks, or heat that is sufficient to cause the dust to ignite.

The Importance of Wire Size

Wire size is measured using the American Wire Gauge (AWG), an industry-adopted scale that sets standard sizes. Smaller AWG numbers represent larger wire sizes. Number 14 wire is the smallest size allowed in most structures; however, in agricultural structures, the wire used should not be smaller than number 12 wire. Wire sizes range from 4/0, which is about ½ inch in diameter, to 20+. Figure 3.3 shows some common wire sizes.

One reason that wire size is an important consideration is ampacity. Ampacity, which is measured in amperes, is defined as the safe carrying capacity of the wire. The greater the amount of amperes flowing through the conductor, the greater the amount of heat produced. Doubling the amperes without changing the wire size will increase the heat output by four times. If the amperage is too high for a prolonged period, it may damage the insulation and lead to a fire.

Wire size is also important because of voltage drop. Voltage drop is the loss of electrical pressure over a length of wire. While some voltage drop is expected, and a 2 percent drop is acceptable, excessive voltage drop is wasted power. Machinery and equipment that run at lower than rated voltages work inefficiently. At 90 percent of its rated voltage, a motor produces only 81 percent of its normal power, and a lamp produces only 70 percent of its normal light output. Wire size affects voltage drop; a larger conductor provides a larger surface for more complete electrical flow. If more amperes are pushed through a conductor than its size allows, increased friction results, causing heat buildup and voltage drop.

The types of wires approved for agricultural buildings are UF and NMC cables as well as other cables or raceways, which are enclosures like tubing that the cable runs through, that are highly resistant to corrosion. Both UF and NMC cables are approved for the two categories of structures, although UF cable is generally to be used underground; it can be used aboveground, but not in highly corrosive situations. The wires and fixtures in buildings with excessive dust must be “dust-ignition-proof” to protect against

Selecting the Proper Wire Size

Some key information is needed before the appropriate wire size can be determined. The following information is required for calculating wire size: amperage load, voltage, wattage, and the length of run. The type of wire

installation used, such as open air or buried wire, is also important, since larger wires are needed overhead for support and because of the voltage leak that occurs in these situations.

Using the information given in Table 3.1, wire size can be determined by using amperage,

Electricity

voltage, wattage, and the length of the run. Suppose that a wire carrying 30 amperes at 240 volts will run a one-way distance of 120 feet. Thirty amperes at this voltage is 7200 watts; to cross a distance of 120 feet requires a number 8 wire. When using the table given, always round up the calculated wattage in consideration of future growth and increased power conditions. If the distance the wire is to span falls between the distances given on the table, use the longer distance and the larger wire.

Use the section of the table describing the wire sizes needed for 240 volts whenever calculating the sizes of wires running into the service panel and to appliances and equipment that require 240 volts. A good strategy is to calculate the wire size as if it will be carrying 240 volts, because the wire can then be used for either 240 or 120 volts.

Beyond the basic considerations, overhead wires pose other requirements. The wires need to be large enough to support themselves without sagging and to maintain some rigidity under

heavy snow loads. To carry 600 volts or less, AWG 10 is recommended for spans up to 50 feet in length. Number 8 wire is needed for longer spans. To carry over 600 volts, AWG 6 is needed where individual conductors are used, and number 8 where conductors form a cable. For all wiring distances over 150 feet, a second pole is recommended.

Feeder Wires

Electrical power is brought to the farm by a power company. The service drop from the power company ends at a centrally located yard pole rather than a building. Feeder wires span the distance from the electrical service equipment at the pole to the service panel at each individual structure, as illustrated in Figure 3.4. They are either SE or USE wire, depending upon whether the service will be installed overhead or underground.

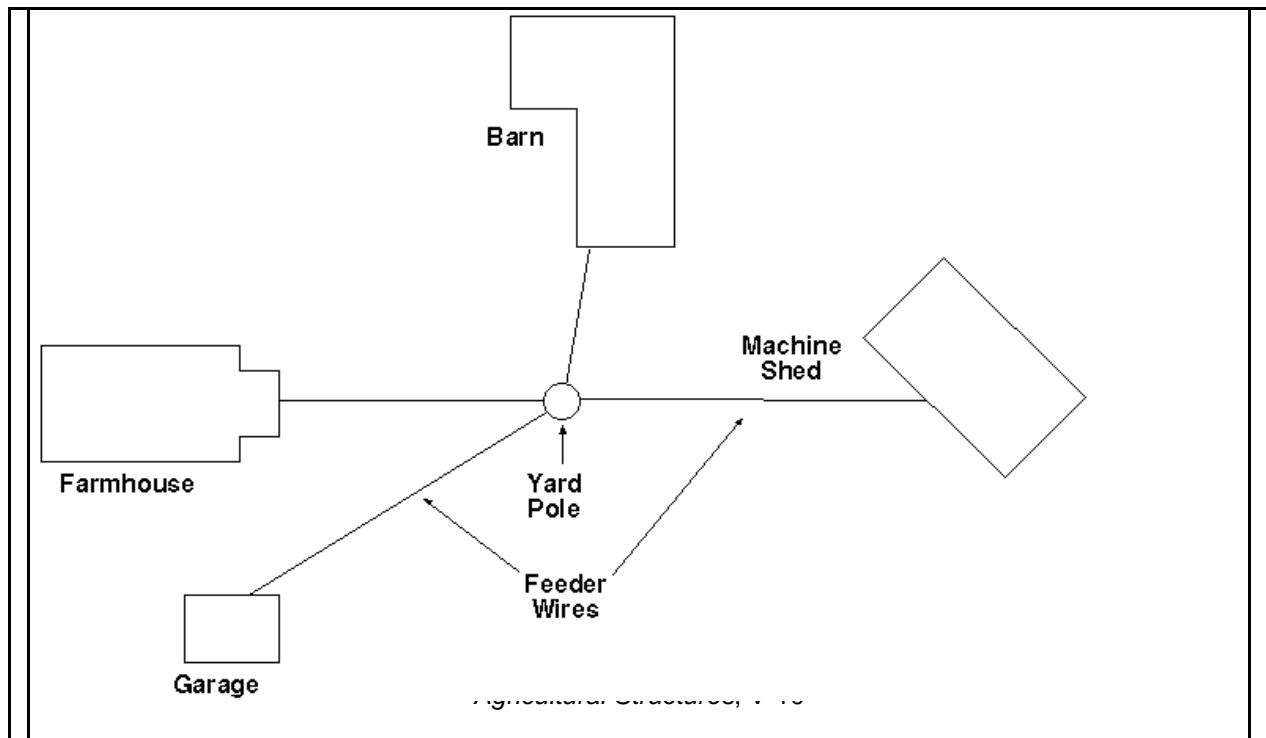

Lesson 3: Wire Types and Uses

One-Way Distances (in Feet) at 120 Volts, Single-Phase, with 2% Voltage Drop												
Amps	Watts	AWG Wire Sizes										
		14	12	10	8	6	4	2	1/0	2/0	3/0	
5	600	90	140	225	360	570	910					
10	1200	45	70	115	180	285	455	725				
15	1800	30	45	70	120	190	300	480	765	960		
20	2400	20	35	55	90	145	225	360	575	725	915	
25	3000	18	28	45	70	115	180	290	460	580	730	
30	3600	15	24	35	60	95	150	240	385	485	610	
40	4800			28	45	70	115	180	290	360	455	
50	6000			23	36	55	90	145	230	290	365	

One-Way Distances (in Feet) at 240 Volts, Single-Phase, with 2% Voltage Drop															
Amps	Watts	AWG Wire Sizes													
		14	12	10	8	6	4	2	1/0	2/0	3/0				
5	1200	180	285	455	720	1145									
10	2400	90	140	225	360	570	910	1445							
15	3600	60	95	150	240	380	610	970	1530						
20	4800	45	70	115	180	285	455	725	1150	1450					
25	6000	35	55	90	140	230	365	580	920	1160	1450				
30	7200	30	48	75	120	190	300	480	770	970	1220				
40	9600			36	56	90	140	230	360	575	725	915			
50	12000			45	70	115	185	285	460	580	725				
60	14400				60	95	150	240	385	485	610				
70	16800					50	80	130	205	330	410	520			
80	19200						70	115	180	285	360	460			
90	21000							60	100	160	260	320	405		
100	24000								55	90	145	230	290	365	
125	30000									75	120	190	240	300	
150	36000										95	150	195	245	
200	48000											70	115	145	185

Feeder Wires and Demand Load

The size of the feeder wire depends on the demand load for a structure. The demand load of an agricultural structure is typically considered to be the amount of power that will likely be needed at any given time. Normally, the minimal calculated demand load is about 35 percent of the total connected load, which is the maximum amount of power that would be drawn if all circuits and appliances were in use. A demand load factor of 35 percent (.35) suggests that only 35 percent of the electrical system will be active at a given time. However, depending upon the type and use of the electrical system within the structure, this percentage may be higher. The approximate amperage that will be in use will determine the necessary feeder wire size.

Feeder Wire Size, Length, and Voltage Drop

The length of the wire plays a major part in determining the size of the feeder wire. Because length tends to be a fixed factor once the yard pole is in place, the size of the feeder wire must then be increased to avoid voltage drop if demand loads or amperage requirements increase. A good rule of thumb is to place the pole or power source as close as possible to the building or buildings that will have the highest electrical use, which will reduce the costs associated with buying larger wire sizes as well as the effects of voltage drop. It is important to note that the wire distances given in Table 3.1 are based on a 2 percent voltage drop. If a higher voltage drop is acceptable, the length can be increased. For example, for a 4 percent voltage drop, double the distance shown on the table for each wire size.

Circuit Needs of a Structure

Several rules of thumb may be applied when calculating the circuit needs of a structure, although the codes required for buildings may vary by county and type of structure. For example, at least one lighting and/or convenience outlet is required for every 150 square feet of floor space. Each square foot of floor space should have a minimum of 3 watts of lighting; most structures will require more.

Convenience outlets should be installed every 12 feet along walls.

Various circuit sizes are recommended for branch circuits, which are separate electrical paths that extend from the service entrance panel and have their own overcurrent protection devices. For 500 square feet of floor space, a branch circuit with a 20-amp minimum is necessary, while a 15-amp branch circuit is the minimum needed for every 375 square feet of floor space. A water heater requires a branch circuit of 30 amps, carrying 220 volts. A ventilation fan calls for a branch circuit of 20 amps, carrying 110 volts. Both a water pump and workshop bench should have a branch circuit of 20 amps, carrying 110 or 220 volts.

Calculating Load

To calculate the load of an agricultural building, complete the following steps. An example is given to show how the steps are applied. The same process can be used to calculate the total load and demand load of branch circuits.

- List the number of circuits, special appliances, motors, etc. to be used.
- Determine the total volt-amperes (VA), or watts (W), for each by multiplying their amperage and voltage requirements; then multiply each one by the number of power outlets of that type.
- Add the numbers to determine total wattage of the structure.
- Multiply by the demand load factor. If in doubt about the size of the demand load, use a higher percentage to take into account future growth and the maximum electrical use at a given time.

Suppose that a structure has ten lighting circuits, five outlets, three motors, and a heater all at 240 volts. The distance from the yard pole to the building is 100 feet. The demand load factor will be 50 percent. What would the demand load be?

Circuits and appliances:

- 10 lighting circuits, generally calculated at 400 W
- 5 outlets, generally calculated at 200 W

Lesson 3: Wire Types and Uses

3 motors, at 1200 W, 2000 W, and 3000 W
1 heater, stamped with a rating of 5000 W

$10 \times 400 \text{ W} = 4000 \text{ W}$
 $5 \times 200 \text{ W} = 1000 \text{ W}$

W requirements:

$(1200 \text{ W} + 2000 \text{ W} + 3000 \text{ W}) \times 0.50 = 3100 \text{ W}$ (Use .5 as a multiplier if all the motors do not run at the same time.)
Heater = 5000 W

Total W: $4000 \text{ W} + 1000 \text{ W} + 3100 \text{ W} + 5000 \text{ W} = 13,100 \text{ W}$ or 13.1 kW

Demand load: $13.1 \text{ kW} \times 0.50 = 6.55 \text{ kW}$, or 6550 watts

Once the demand load has been calculated, the proper feeder wire size can be chosen. For example, in the problem given here, the wire size must be AWG 8 to carry the wattage and span 100 feet. When determining the wire size needed from the meter base, which is the socket where the electric meter is attached at the yard pole, to the point where the wires break down to the individual structures, the same procedure is used by calculating the total connected load for all buildings and then using the table to determine wire size. Always increase service conductors by one size in consideration of future growth and increased power load.

Summary

The type and size of the wire used is critical to proper electrical installation. The wire, or conductor, directs the electrical current throughout the system, and these conductors must be of ample size to efficiently conduct the current. It is important to be able to calculate electrical usage and then use this information to determine wire size, while taking into account future demands and expansion.

Credits

Holzman, H.N. *Modern Residential Wiring*. South Holland, Ill.: Goodheart-Willcox Company, Inc., 1986.

Richter, H.P., and W.C. Schwann. *Wiring Simplified*. 38th ed. Somerset, Wis.: Park Publishing, Inc., 1996.

Lesson 4 : Grounding and GFCI Protection

Lesson 4: Grounding and GFCI Protection

Electricity can be thought of as a living entity moving along a path through a circuit. However, if that circuit is interrupted, the electrical current still seeks a path to the earth. A ground wire is a safe method of establishing this necessary link by providing a path for the current. However, if a person uses a piece of equipment that is shorted out or improperly grounded, she or he may become the access point for grounding that the electrical current is seeking. Therefore, ground fault circuit interrupters are a crucial safety device, especially in damp areas.

Grounding and Its Importance

Grounding forms the connection between a piece of equipment or electrical appliance and the earth. It provides electricity an alternate path back to its source. The grounding point is typically established at or near the service entrance panel where electricity enters a structure. It may consist of a metal rod made of solid copper or copper-clad metal driven into the ground that is connected directly to the service panel with a ground wire. A grounding system may also consist of a grounding wire attached to an established galvanized metal water pipe.

The grounding system is connected to appliances and electrical equipment through a dedicated ground wire that is isolated from the power conductors in the electrical system. This wire may be connected either to the equipment directly or to the electrical outlet receptacle. The ground wire leads back to the ground connection at the service panel.

Grounding is important in the prevention of electrical shock. It provides a safety measure for channeling an electrical current that is out of the electrical circuit back to the earth at the source. This safety measure helps direct the charge away from humans or livestock who might come into contact with a shorted appliance or equipment.

NEC Requirements for Grounding

According to the NEC, grounding has three main purposes. First, it limits voltages in an electrical system due to lightning, line surges, or unintentional contact with higher voltage lines. Second, grounding helps stabilize voltages within the system. Finally, it provides a path to facilitate the operation of overcurrent devices.

NEC regulations state, "Premises wiring shall not be electrically connected to a supply system unless the latter contains, for any grounded conductor of the interior system, a corresponding conductor that is grounded." Basically, this statement means that the proper grounding rods must be in place and connected to the electrical system prior to making the electrical connection to the power source.

NEC regulations also describe the types of grounding systems allowed. The code states that the ground rod conductor is to be connected at the point where the electrical service enters the service panel. Also, all connections to the ground rod must be made at the service panel and the entrance point to the service panel, not on the individual circuits of the electrical system.

The grounding electrode, or ground rod, should be as near as practical to the service entrance.

GFCIs

Putting faith in the grounding wire in a 3-wire electrical system is not always justified. A faulty ground wire could lead to a lethal shock. Therefore, using GFCIs is best in any situation where a potential shock hazard exists.

GFCI stands for ground fault circuit interrupter. A GFCI is a device that interrupts the circuit to any electrical device when a fault current, or a current which has moved out of its normal circuit, exceeds a predetermined level. The level is less than that required to operate the overcurrent protective device of the supply circuit. The primary function of a GFCI is to interrupt the flow of the current to prevent people and animals from being shocked.

A GFCI operates by monitoring the magnitude and time of electrical flow. The GFCI will interrupt abnormal electrical flows of 5/1000 amperes in 25/1000 of a second. These small amounts of amperage will not trip a regular electrical breaker or fuse.

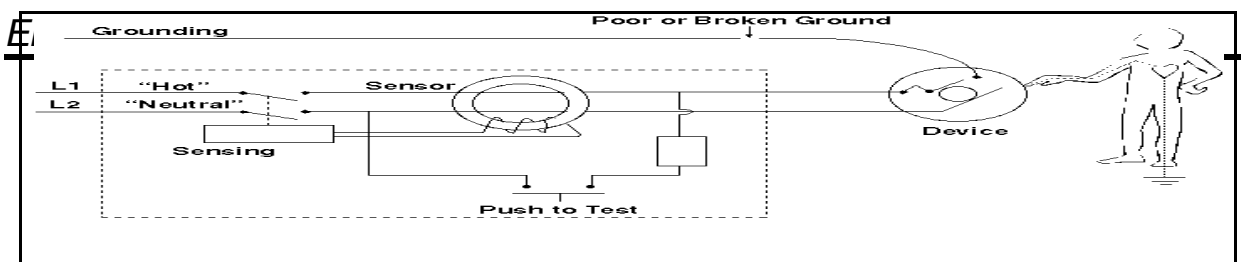

GFCIs work by sensing imbalances in electrical circuits caused by shorts or other faults. When an imbalance occurs between the black “hot” wire and white “neutral” conductors, an uneven electrical load exists in the system, and a ground fault current is present and seeking a return conductor to the source. A person or animal coming in contact with the fault current can provide this path, creating a shock hazard. The GFCI prevents shocks by stopping the electrical flow, as illustrated in Figure 4.1.

NEC Requirements for GFCIs

The NEC establishes where GFCIs should be installed. According to the NEC, GFCI protection is required for all outlet receptacles or any devices permanently wired into the electrical system that are installed in the locations listed.

- Bathrooms
- Garages and grade level portions of unfinished accessory buildings used for storage and work areas
- Outdoors
- Crawl spaces, where the crawl space is at or below ground level
- Unfinished basements and areas not intended as habitable rooms and limited to storage areas, work areas, and the like
- Kitchens, where the receptacles are installed to serve counter top surfaces
- Indoor or outdoor swimming pools
- Hot tubs
- Portable signs
- Any location using temporary power

Installation of GFCIs in Agriculture Structures

Four types of GFCI units are used in agriculture structures. They are the circuit breaker GFCI, the plug-in GFCI, the portable GFCI, and the outlet-type GFCI, all of which are pictured in Figure 4.2. The selection of one of these types for use in a particular structure depends on the requirements of the structure.

Circuit breaker GFCI - This type of GFCI is a fixed, permanently installed unit. It substitutes for a standard circuit breaker and controls the outlets within an entire circuit.

Plug-in GFCI - This device is designed for use in existing electrical systems that do not have GFCI devices installed. It plugs into a regular receptacle and protects only those appliances plugged into it.

Portable GFCI - The portable GFCI is similar to the plug-in type, except this device has an extension cord and is portable. It plugs into standard outlets. This GFCI is generally used for construction and short term circuit protection needs.

Outlet-type GFCI - As its name suggests, this GFCI is permanently mounted in an outlet box. It protects all the items plugged into it. The outlet-type GFCI is widely used in the construction of new buildings.

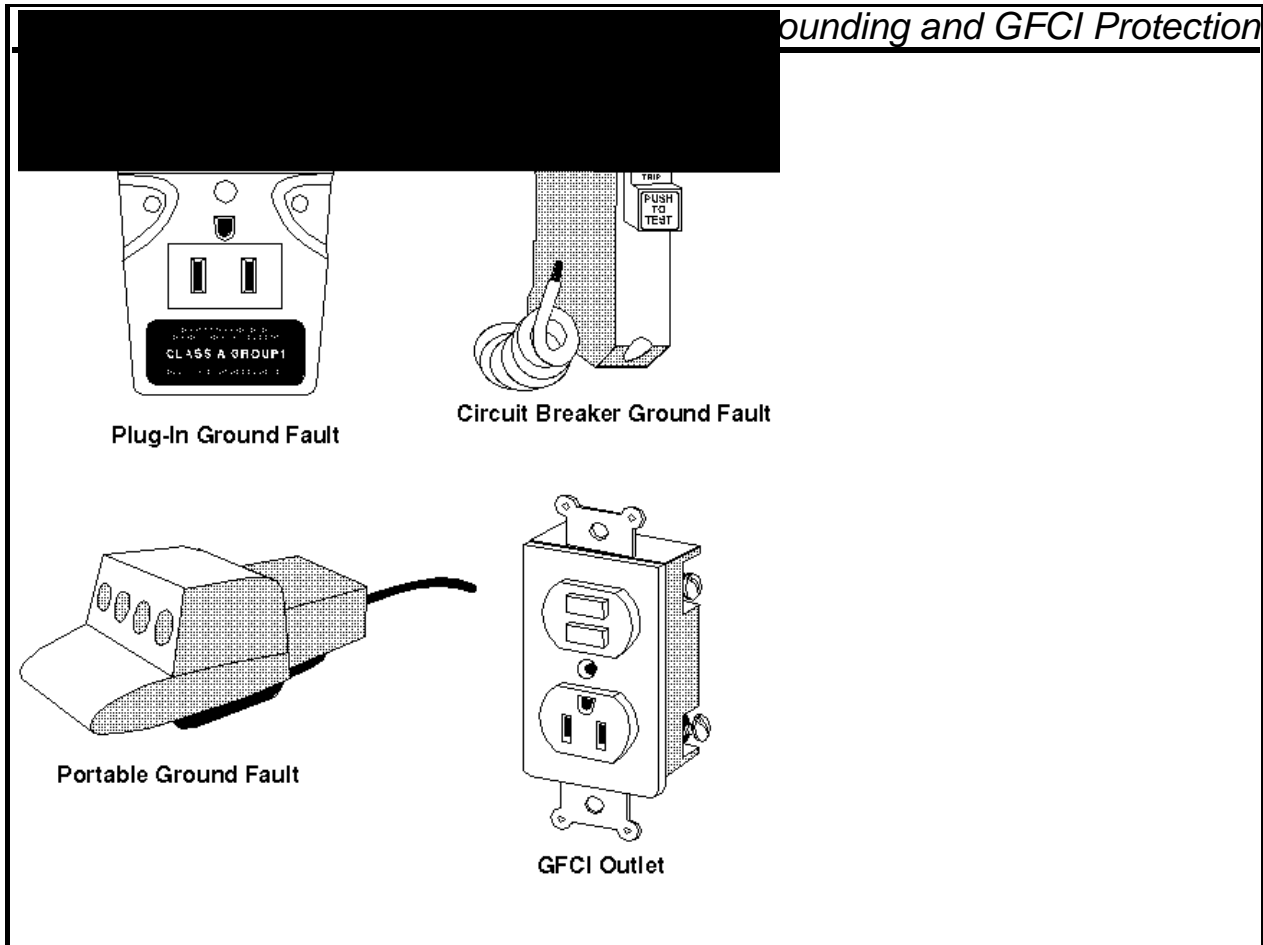

Summary

The use of proper grounding and GFCIs in electrical systems is a critical component in construction for the home and farm. They provide a safety feature that protects humans and animals from electrical shock hazards and the electrical system from hazardous overloads. The requirements for this protection are addressed very specifically by the NEC, with regulations governing the application and use of grounding systems and GFCIs.

Phipps, Lloyd J., and Carl L. Reynolds. *Mechanics in Agriculture*. 4th ed. Danville: Interstate Publishers, Inc., 1990.

Credits

Cooper, Elmer L. *Agriculture Mechanics: Fundamentals and Applications*. 2nd ed. Albany: Delmar, 1996.

"Electrical Code." <http://anna.texoma.net/Nonprofit/City/Code/Index.htm> (22 Jan. 1999).
 Kardon, Redwood. "Code Check: Help with Building Codes." <http://www.codecheck.com/frame.htm> (22 Jan. 1999).

Lesson 5: Lights, Outlets, Switches, and Circuit Protection

Lesson 5: Lights, Outlets, Switches, and Circuit Protection

The primary intent of electrical wiring is to provide a convenient source of power for lighting and mechanical needs. These needs are met through the use of lighting systems, outlets, and switches. In planning the wiring of an agricultural structure, safety standards from the NEC and local rules and regulations must be followed.

Rules for Lighting Outlets in Agricultural Structures

Light fixtures must be appropriate for the environmental conditions that will be present in agricultural structures. Because of the nature of these structures, most will have wet or dusty environments. Therefore, specific measures must be taken when planning lighting outlets for these structures.

In wet areas, the NEC requires the use of a nonmetallic light fixture. These fixtures are to be made of nonconductive materials, such as porcelain, plastic, or rubber.

In areas where dust is a problem, such as a feed elevator or hay barn, dust-tight light fixtures are required. These fixtures prevent combustible materials from coming into contact with electrical connections that produce sparks.

Types of Lighting and Their Uses

Another important consideration in agricultural structures is the type of lighting to be used in a particular structure. To choose the best alternative, being familiar with the different types of light sources and the uses of each is necessary.

When discussing light sources such as light bulbs and fluorescent tubes, the term "lamp" is used. A lamp is a mechanism that produces light when an electrical current passes through it.

Larger lamps will be more efficient and provide more light per watt of power used. For instance, three 60-watt lamps will provide 10 percent more light than five 40-watt lamps. The difference in wattage is an important consideration when

planning the number of fixtures and the wire size to be used in a structure.

Numerous types of lighting are available. Incandescent lamps are the most familiar type. These lamps produce light when electricity moves through a wire filament that then glows at a white heat. The electricity heats the filament to more than 4,500 degrees Fahrenheit. The high temperature makes the filament give off light. This type of lamp is inefficient because much of the electricity used is changed to heat instead of light.

Another group of lamps are known as gaseous discharge lamps. These lamps pass an electric current through a gas enclosed under pressure in a tube or bulb. This process, referred to as electric discharge, produces light when the current moves through the gas particles. Two types of gaseous discharge lamps are available: low pressure gaseous discharge lamps, such as fluorescent lamps and low pressure sodium lamps, and high pressure gaseous discharge lamps, such as mercury vapor lamps, metal halide lamps, and high pressure sodium lamps.

Fluorescent lamps are made up of a glass tube that contains mercury vapor and argon gas under low pressure. Electricity flowing through the mercury vapor produces ultraviolet energy. This energy turns to visible light after striking the fluorescent coating on the inside of the tube; the coating is made up of phosphors, which are solid, nonmetallic chemical elements. Fluorescent lamps are used indoors. Because of advances in light quality, they can be used effectively for supplementary lighting in greenhouses. Fluorescent lamps are also made in a compact form for use in light sockets usually used for incandescent lamps.

Low pressure sodium lamps consist of two glass tubes, one inside the other. The inner tube contains solid sodium and a mixture of argon and neon gas. The outer tube provides a protective barrier for the lamp. When electricity moves through the inner tube, the gases react with the electricity to produce heat and an orange-colored light. As the sodium heats up, it vaporizes, and the lamp gives off a yellow light. These lamps are commonly used for street lights in towns.

Electricity

Mercury vapor lamps also have a two-bulb configuration. The inner bulb is made of quartz and is called the arc tube. The arc tube contains mercury vapor at a high pressure, which allows it to produce visible light without the presence of phosphors. The light produced is greenish blue in color. These lamps have a longer life than other lamps of similar wattage. However, it may take 5 to 7 minutes for vapor pressure to build up and reach full brightness. Mercury vapor lamps are primarily used outdoors around farms and homes to light the outside of buildings.

Metal halide lamps contain compounds of metal and halogen with the same basic two-bulb design. These lamps produce more naturally colored light than do mercury vapor lamps. Metal halide lamps also have a long life and high light output. They are an excellent outdoor light source and have some indoor applications as well, such as supplementary lighting for greenhouses.

High pressure sodium lamps are similar to mercury vapor lamps. The difference is that the arc tube in the two-bulb configuration is made of aluminum oxide. The tube contains a solid mixture of sodium and mercury. These lamps produce an orange-white light and have a long life and very high light output. They are also used outside around homes and farms.

Rules for Convenience Outlets in Agricultural Structures

Convenience outlets are the points in the wiring system where electric power is used, such as electrical receptacles. They allow electrical appliances to be plugged in as necessary. A sufficient number of convenience outlets must therefore be included when planning agricultural structures.

Some basic guidelines are followed in determining the location of convenience outlets. First, outlets are installed where animals will not readily bump into them. Generally, they should be at least 5 feet above ground level anywhere livestock may be present. Also, they must be easily accessible. The outlets should be mounted between the studding or flush with the wall.

For agricultural structures, the correct type of convenience outlet must be used. They must be 20-amp duplex receptacles with a safety ground. A GFCI receptacle is preferable, especially in damp areas. Also, due to the environmental conditions in most agriculture structures, nonmetallic outlet boxes are necessary.

The number of convenience outlets installed within a structure depends on the amount of use the outlet will receive and the building type. For livestock buildings, 12 to 15 feet between outlets is recommended. In other structures, 8 to 10 feet of space is acceptable. A good rule of thumb when planning for convenience outlets is to install enough outlets so that extension cords will not have to be used on a regular basis.

Rules for Switches in Agricultural Structures

Switches are an important component in the electrification of agricultural structures. Switches control everything from lighting to motorized equipment. A major use of switches in agricultural structures is as safety disconnect devices. These switches shut off power to rows of receptacles on a single circuit or to motors when not in use.

The location of switches should be based on convenience and ease of access. Switches should be installed at elbow height in protected spots. If possible, the switch should be on the latch side of doors and on the traffic side of arches. When multiple doors provide access to a single room or bay, multiple switches are needed if the doors are farther than 10 feet apart.

Electrical Protection for Agricultural Structures

Because of the damp and corrosive environments typically found in agricultural structures, electrical protection is a priority in these buildings. Overcurrent devices and proper grounding procedures are a must. Branch circuits must contain adequate amperage-rated fuses or circuit breakers, which is calculated based on the anticipated use of the circuit. Proper grounding is also an important consideration. All noncurrent carrying devices, or ground wires connected to motor housings or

Lesson 5: Lights, Outlets, Switches, and Circuit Protection

to equipment, should be grounded. The system ground wire to the ground rod must be the same size as the wires carrying electrical current. For example, if the hot and neutral wires are AWG 12, then the ground wires must also be AWG 12.

The building must have enough circuits to carry out business efficiently. General purpose circuits that must be considered in planning are permanent lighting circuits, convenience outlets, any special lighting circuits like automatic on/off outdoor lights, and portable heater units. Also, the service entrance panel should have open circuit spaces for anticipated electrical expansion.

Some limitations apply to the use of branch circuits. Branch circuits should not operate at more than 2 percent voltage drop or use wire smaller than AWG 12. The electrical load is not to exceed 80 percent of the branch circuit rating, which is the rating of the branch fuse or circuit breaker. Fixed appliances must not be over 50 percent of the load if lighting is also included on the circuit.

Summary

When planning the electrical wiring of an agricultural structure, identifying the requirements for lighting, outlets, and switches

General Recommendations for Branch Circuits

Branch circuits are the primary electrical connections for all uses within the agriculture structure. Therefore, it is very important to carefully plan the uses and load of these circuits. for that building is crucial. Using materials designed for the typical uses and environmental conditions of these structures is also important. As in any structure, electrical protection and good circuit design are necessary. Careful planning is required to design a system that will meet current and future demands.

Credits

Holzman, H.N. *Modern Residential Wiring*. South Holland, Ill.: Goodheart-Willcox Company, Inc., 1986.

Missouri Department of Natural Resources. "Division of Energy." <http://www.dnr.state.mo.us/de> (25 Jan. 1999).

Richter, H.P., and W.C. Schwann. *Wiring Simplified*. 38th ed. Somerset, Wis.: Park Publishing, Inc., 1996.

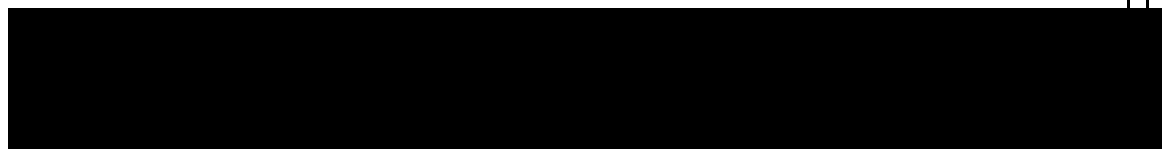

 Similar Lamp Fixture

 Surface or Pendant Individual Fluorescent Fixture

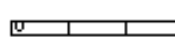
 Surface or Pendant Continuous Row Fluorescent Fixture

 Blanked Outlet

 Junction Box

Wall

 To indicate wall installation of above outlets, place circle near wall and connect with line as shown.

 Single Receptacle

 Duplex Rec

 Triplex Rec

 Duplex Rec Split Wired

 Single Spc Receptacle

 Duplex Spc Receptacle

 Range Out

 Clock Hang

Lesson 5: Lights, Outlets, Switches, and Circuit Protection

Lesson 6: *Electrical Symbols in Wiring Plans*

Lesson 6: *Electrical Symbols in Wiring Plans*

The use of symbols in wiring plans is a standardized method of identifying the location of electrical components. Familiarity with these symbols is necessary to read plans and correctly install electrical systems.

Lighting, Receptacle, and Switch Outlets

The symbols in Figure 6.1 are those most commonly used to identify electrical lighting outlets. In describing light fixtures, the symbols identify those fixtures that are surface mounted into or onto the wall or ceiling and those that hang from hardware in the ceiling. Blanked outlets are outlets with cover plates placed over the boxes. They have wires in the box which may be used for future lighting or power needs. Junction boxes are those electrical boxes in which circuit wires are routed to different locations in the structure.

Symbols are also used to indicate the different types of receptacle outlets commonly included in agricultural structures. These symbols are shown in Figure 6.1. Receptacle outlets include standard outlets with one, two (duplex), or three (triplex) outlets per box and specialized receptacle outlets. Letters next to the symbol for specialized outlets indicate their purpose; for example, DW would stand for dishwasher. Some specialized outlets, such as special purpose outlets that have modified plug

openings for specific applications, are diagramed for 110-volt systems. Range outlets describe 220-volt receptacles. Clock hanger receptacles are specialized low amperage outlets designed to be used with electric clocks.

Special symbols are used to represent switch outlets as well. Switch symbols note the number of poles, or terminal connection points on the switch, and if the switch connections are for three- or four-way light systems with multiple switches. Other specialized switches identified are those with a lamp on the switch, switches with outlet receptacles included at the location, automatic door switches, switches that have built-in timers to turn them on or off, and ceiling pull switches. Figure 6.2 shows the symbols for these switches.

Power, Fusing, and Grounding

Symbols are also used to identify electrical power sources, circuit overload protection devices, and grounding sites of the agricultural structure, as shown in Figure 6.2. Those power sources typically identified for agricultural purposes are electric motors installed in the system, electric generators, and power transformers for power conversion, as in 3-phase electric power systems. The locations of watt-hour meters, grounding sites, and circuit breakers and fuses in branch circuits are all indicated by special symbols.

Electricity

Panelboards, Switchboards, and Related Equipment

Symbols related to the power and fusing systems identify panelboards at the service entrance and switchboards and switch controllers for electrical motor operations. These symbols are illustrated in Figure 6.3.

Remote Control Stations for Motors or Other Equipment

Other symbols related to the operation of motors are shown in Figure 6.3. Push-button stations are electric switches that use a button-type on/off switch to control electric motors. Remote control stations are those locations where electric motor switches are in a location that is not directly attached to the motor that the switch operates. Float, limit, and pneumatic switches are all specialized variations of remote switches. Thermostat switches are switches used to control electric motors or other electric devices; they are activated by changes in air temperature.

Miscellaneous Connections

Because of the environmental conditions present in most agricultural structures, specialized electrical equipment is installed. This

equipment is identified using a special group of electrical symbols. Figure 6.3 shows these symbols. For example, some of the symbols identify electrical fixtures that are designed to provide protection from weather, water, dust, flammable vapors, and explosions caused by combustible materials. They also indicate grounded (GFCI) and recessed devices.

Summary

In order to successfully wire a building, being able to read electrical wiring diagrams is a must.











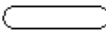

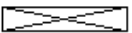

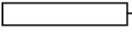
The symbols shown in this lesson are those commonly used in agricultural structures. Familiarity with these symbols will help in correctly installing electrical wiring.

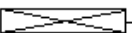
Credits

Cooper, Elmer L. *Agriculture Mechanics: Fundamentals and Applications*. 2nd ed. Albany: Delmar, 1996.

Holzman, H.N. *Modern Residential Wiring*. South Holland, Ill.: Goodheart-Willcox Company, Inc., 1986.

Phipps, Lloyd J., and Carl L. Reynolds. *Mechanics in Agriculture*. 4th ed. Danville: Interstate Publishers, Inc., 1990.

Panelboards, Switchboards, and Related Equipment	Remote Control Stations for Motors or Other Equipment	Connections
 Surface-Mounted Panelboard and Cabinet	 Push-Button Station	 Weatherproof
 Motor or Other Power Controller	 Float Switch - Mechanical	 Watertight
 Externally Operated Disconnection Switch	 Limit Switch - Mechanical	 Dust Tight
 Combination Controller and Disconnection Means	 Pneumatic Switch - Mechanical	 Grounded
	 Thermostat	 Vapor Tight
		 Rain Tight
		 Explosion Proof
		 Recessed

Lesson 7: Running Electrical Wiring

The electrical service pole is the central hub for power distribution on an agricultural operation. The installations made at the yard pole, the main service entrance, and the meter should be made by an electrical contractor or the power company.

However, understanding the configuration at the pole is important in completing further wiring installations or making repairs to the system.

The Configuration at the Pole

Three wires bring electricity in from the power company to an agricultural operation. These wires include two hot wires and one neutral wire.

The wires are connected to the meter base at the yard pole, and power is distributed to the different structures from the pole. The grouping of the wires at the pole is called the stack.

Connections at the pole are relatively simple. All of the wires carrying power in to or out from the pole are connected directly to the pole with

insulators. The stack may have either a single stack or a double stack, as shown in Figure 7.1. In single stacking, the wires that travel into the meter from the power company and those wires traveling out to individual structures are both contained within a single conduit attached to the pole.

In double stacking, the supply wires coming in from the power company use a separate conduit from the wires that lead out to the individual structures. This configuration is used for both overhead and underground wiring installations. Double stacking is utilized when a large number of structures are being served by one meter.

A separate ground wire that is connected to the neutral wires runs along the outside of the conduit to a ground rod. This form of electrical grounding is best for handling lightning. The ground wire should be AWG 6 in size.

insulators. These insulators should be heavy enough to withstand weather conditions and are typically made of ceramic. Two racks of

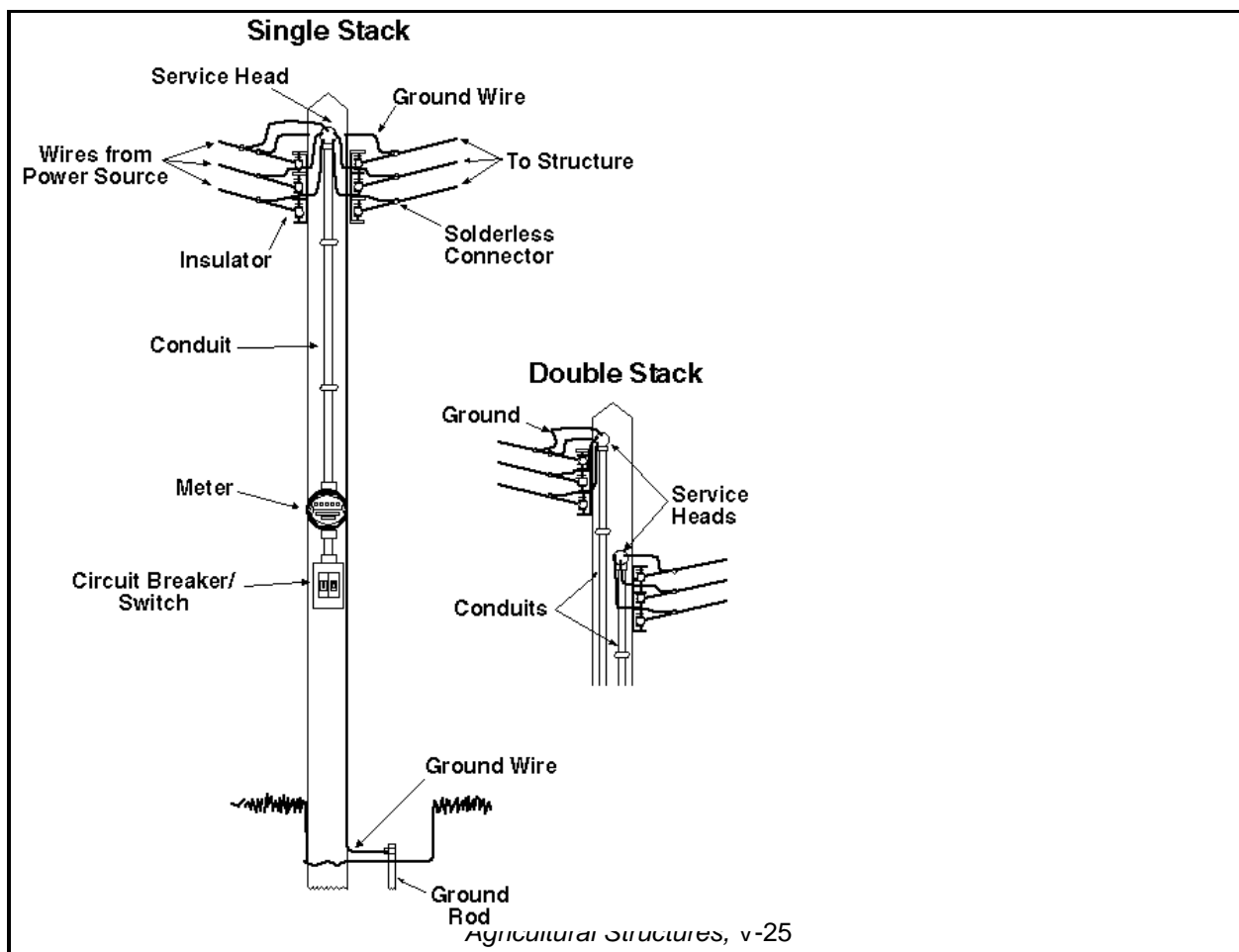

Electricity

insulators with three insulators per rack are required, one rack for incoming wires and the other for outgoing wires. The insulators should be anchored with heavy lag screws and at least one through bolt inserted through the pole for added strength. Insulators are not needed for underground wiring because the wires are fed through a buried conduit.

Feeder wires are used to carry power to the meter base. They are attached to the supply wires with solderless connectors. Once the splice is made, these connectors should be taped to provide insulation. The feeder wires then enter the conduit through the service head, which is a special fitting that is angled to keep water from entering the conduit. The wires run down the conduit and then attach directly to meter base.

Short feeder wires are attached from the meter base to the main power disconnect switches at the pole. A disconnect switch should be available for all individual electrical service systems to which power is supplied. For individual electrical systems, two structures may be operated off of one.

The size of the feeder and supply wires traveling from the disconnect switches to the structures will be determined by each structure's demand load. The supply wires are either attached to the pole with insulators or buried underground.

Installing the Service Entrance

Once the configuration at the pole is in place and the amperages determined for the individual structures, the service entrance needs to be installed. NEC regulations determine the size and type of wire used at the service entrance. According to the NEC, AWG 8 wire is allowed if up to two two-wire circuits are being installed, and AWG 6 is allowed if up to five two-wire circuits are being installed. For bigger systems, amperage calculations and wire size tables are needed to determine the proper wire size.

The type of power service required in the structure will determine if the service entrance will have a two-wire or three-wire type service.

Using Branch Circuits

When planning an electrical system, it is important to consider how many branch circuits

A two-wire system has 110 volts available for use, which is acceptable for small sheds or buildings that will have only lights or outlet receptacles in use. A three-wire system has both 110 and 220 volts available for use within the structure. It can provide electricity for equipment requiring 220 volts, such as a welder.

The location of the service entrance is an important consideration. The location of the SEP should be determined prior to running wires from the power pole. NEC guidelines indicate that the SEP should be as close as practical to the point where wires enter the building. If possible, the service box should be near equipment that requires higher 220-volt electrical loads to reduce expensive wire runs and voltage drop. The SEP should be installed in a location that is easily accessible.

The wire connections at the building are similar to those at the yard pole. Insulators are connected to the structure for overhead runs of wire. The feeder wires connect to main wires and then run into the service head, through the conduit, and into the service entrance panel (SEP). Figure 7.2 illustrates the service entrance.

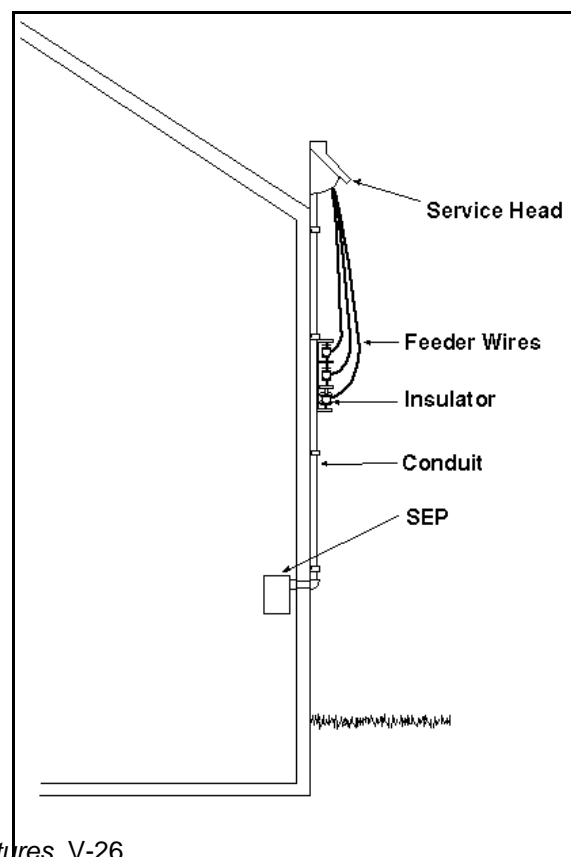

Lesson 7: Running Electrical Wiring

will be necessary within a structure. The type of structure and its use will be determine the number of circuits needed. Small sheds with lighting need only two branch circuits. The second circuit allows for backup lights if one circuit blows. Larger structures, such as shops and barns, typically need 110/220-volt service because they often have equipment that requires 220 volts. Each 220-volt outlet requires a separate circuit, which is made by combining two 110-volt circuits at the service entrance panel. The number of circuits will vary depending on the number of electrical systems and the number and type of appliances used.

When determining the number of circuits needed, careful calculations of the wattage used by all electrical components are necessary. A good rule of thumb is to add additional circuits and break up the system to avoid overload problems.

Planning for expansion is also important when installing the SEP and calculating the need for branch circuits.

Wiring a Barn

Most agricultural structures have special characteristics that must be considered when planning electrical wiring. One of the biggest considerations for barns is their environmental conditions. Barns naturally have damp and corrosive environments and tend to lack proper ventilation. NCM or UF cable is required along with nonmetallic junction boxes that resist moisture.

Another factor to consider is mechanical damage, or damage caused by crushing, pinching, or crimping conductors when livestock, tools or equipment inadvertently come in contact with wires. Running wires along the sides of beams and joists to where fixtures are located provides protection. Wires are also run in protective conduits to prevent mechanical damage.

When planning for electricity in the barn, providing lighting, switches, and receptacles is important. Plenty of lighting should be included throughout the barn. Switches should be easily accessible and mounted at elbow height. Receptacles should be dust tight, watertight, and corrosion resistant. Installing GFCI outlets is a good idea.

Wiring for branch circuits and electrical fixtures is less specialized, however. Carefully planning

Livestock considerations are also a factor in planning electrical wiring. Lights, outlets, and switches should be out of the reach of livestock. This practice will prevent damage to equipment, fire hazards, and shock hazards to animals.

Wiring a Hay Barn

For hay barns, dust is an important consideration.

The dust produced by hay is highly flammable, so precautions must be taken to prevent electrical sparks from coming in contact with the dust. Wires must be enclosed in conduits or within a wall covered with sheathing. Vapor proof fixtures seal out dust from electrical connections. Lighting fixtures should minimize the entrance of dust as well as foreign matter, moisture, and corrosive materials into the exposed wiring areas. In addition, fixtures exposed to physical damage must be protected by a guard, while fixtures exposed to water must have watertight protective coverings.

Selecting Switches and Receptacles

Choosing proper switches and receptacles is an important consideration when planning the wiring of any agricultural structure. The NEC requires that switches, circuit breakers, motor controllers, fuses, push buttons, relays and similar devices be protected from environmental and physical damage. These components should have weatherproof, corrosion resistant enclosures designed to minimize the entrance of dust, water, and corrosive elements. Switches and receptacles designed for outdoor use may be useful because these components tend to be durable and provide protection from environmental conditions.

Summary

Wiring for agricultural operations is in some ways very different than other wiring situations. For example, the use of a centrally located yard pole that acts as a power hub for all the surrounding structures is unique to agriculture. Only trained professionals should connect the electrical service at the pole and meter base and at the main service entrance.

the wiring for a structure is important. In particular, due to the nature of agriculture

Electricity

structures, wiring and fixtures such as lights, switches, and receptacles should have adequate protection from their environment.

Richter, H.P., and W. C. Schwann. *Wiring Simplified*. 38th ed. Somerset, Wis.: Park Publishing, Inc., 1996.

Credits

Holzman, H.N. *Modern Residential Wiring*. South Holland, Ill.: Goodheart-Willcox Company, Inc., 1986.

Lesson 8: Connecting to the SEP

Lesson 8: Connecting to the SEP

Once the wiring is in place in an agricultural structure, the next step is connecting the circuits to the service entrance panel. The SEP is the main distribution point for electrical power in the structure. Within the SEP, individual branch circuits link to the incoming power source, thus providing electrical power to the entire system.

SEP Parts

The parts of the SEP are housed within the service entrance cabinet, as shown in Figure 8.1. The main disconnect switch is a large amperage breaker used to disconnect the power coming into the structure from the individual

circuits. This safety device can be shut off for electrical repairs or emergencies.

Also within the box is a panel with banks, or rows, of sockets designed to accept either circuit breakers or fuses. Generally, some of these sockets will remain open for expansion purposes. The circuit breakers or fuses provide overcurrent protection for the circuits.

Other components of the SEP ground the system. The neutral bar is a specialized bar with terminal screws placed in it to make connections between neutral wires and ground wires. The grounding screw is the point where the ground wire connects to the neutral bar to ground the SEP cabinet. The cabinet can also be grounded using a flexible bonding strap.

Good Wiring Practices

When making the connections in the SEP, following proper wiring procedures is important.

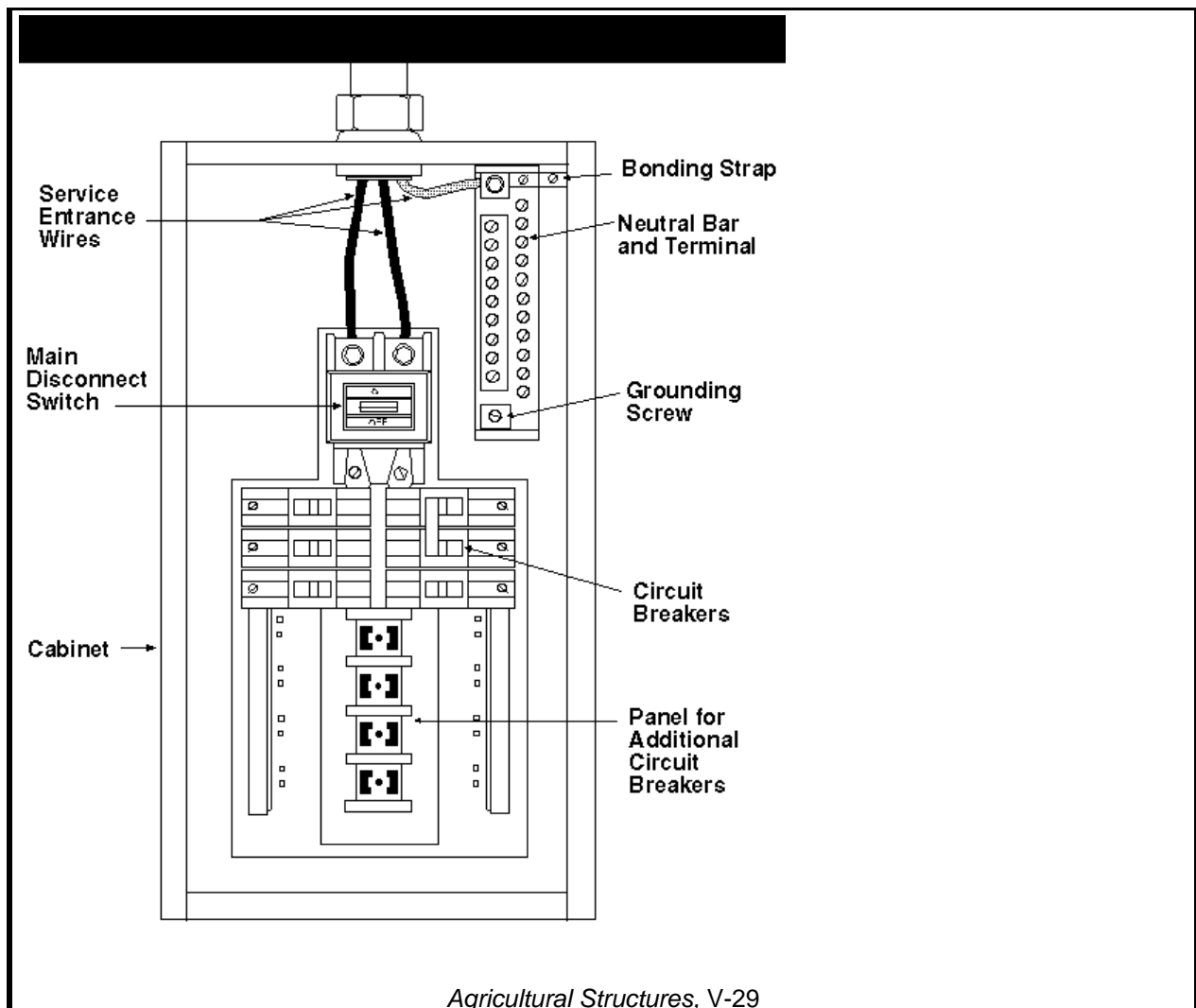

One of the biggest concerns involving the SEP is the buildup of heat and the overheating of wires within the panel. Several wiring procedures can reduce the likelihood of overheating. One way to reduce heat buildup is by wiring neatly and keeping wiring orderly within the cabinet. The SEP cabinet should not have excessive wire in it, so wire runs in the SEP should be kept as straight and direct as possible. Wires should not be bent during wiring, because the constriction of wires can cause insulation damage as well as overheating.

Other good practices should be followed as well.

Tight connections without excessive bare wire showing should be made at the terminal screws.

The neutral bar should be placed in a convenient location in the SEP box to make direct wire runs easier. Wires should be cut to the exact length necessary, removing any excess wire from the box.

Connecting Service Entrance Conductors to the SEP

Service entrance conductors must be connected properly in the SEP. Typically, for 120/240-volt systems, three wires enter the SEP in a bundle of wire. They include two 120-volt hot conductors and one neutral conductor. Two wires make up 120-volt systems, one hot wire and one neutral wire.

The most important thing to do before connecting any wires is to check to make sure that the power is shut off. When the power is off, the two hot conductors, which consist of two black wires or one black and one red wire, are connected to the main disconnect switch. The conductors should be cut to the proper length so no excessive wire is in the cabinet. Then enough insulation is stripped off to make a good connection. The bare ends of the wire are inserted into the connectors on the main disconnect, and the holding screws are tightened securely onto the wires. Using the same procedures, the neutral wire is attached to the neutral bar. The SEP cabinet is then grounded by attaching either the flexible bonding strap or the ground wire to the grounding screw.

Installing the Ground System

Grounding involves connecting a ground wire from the neutral bar in the SEP to a grounding electrode or a ground system. The ground system, in which grounding electrodes are connected together, is the preferred method of grounding. A ground system is pictured in Figure 8.2.

Several different types of electrodes may make up ground systems. One alternative is a buried metal water pipe 10 feet or more in length, which must be supplemented by at least one other electrode. The grounded metal frame of the structure can also serve as an electrode. Another type of electrode consists of a concrete-enclosed electrode composed of either 20 or more feet of ½-inch reinforced steel or AWG 4 copper wire. The steel or wire is placed inside at least 2 inches of concrete located near the bottom of the foundation. It runs through the concrete into the ground, coming into direct contact with the earth. A buried AWG 2 or bigger wire that encircles the entire structure can also be a grounding electrode in a grounding system.

If none of these options for the ground system are available, a grounding electrode is used. Grounding electrodes can consist of underground metal piping or buried metal tanks, a ½-inch copper rod or ½-inch metal or copper-clad rod, a ¾-inch galvanized steel pipe, or a buried metal plate at least 2 square feet in diameter.

The size of the ground wire is another important element of the ground system. The NEC has set the following guidelines for grounding conductors. If the service entrance conductor is AWG 2 or smaller, AWG 6 or 8 wire should be used for grounding. If the service entrance conductor is AWG 1 or 0, AWG 6 is the minimum size permitted for the ground wire. If the service entrance conductor is AWG 2/0 or 3/0, the ground wire should be a minimum of AWG 4.

If wire larger than AWG 3/0 is used at the service entrance, AWG 2 must be used for the ground connection.

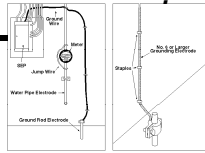

The ground wire must be installed properly. The wire is fastened to the surface over which it runs using special staples. The wire should be installed in a location that will minimize physical damage. Protection is typically provided by either tucking the ground wire behind the service conduit entering the structure or running the wire along wall studs. If AWG 8 or smaller wire is used for grounding, it must be protected with a conduit. However, larger wire sizes do not need this protection.

Selecting and Sizing Circuit Protection

As discussed in Lesson 2, the diameter of the conductors used in the wiring determines the maximum safe amperages. If more than the maximum amperage flows through the conductor, the temperature of the wire will increase. The heat can damage insulation and cause fires. To prevent this from happening, either fuses or circuit breakers are installed in the SEP in each branch circuit.

When planning the installation of the SEP, determining whether fuses or circuit breakers will be used is important. Most modern structures use circuit breakers because they are more

Connecting 120-Volt Branch Circuits to the SEP

Once the service wires have been connected to the SEP, the branch circuits and circuit breakers can be installed and connected. Planning the location of each circuit before beginning the installation is important. The first step in making the connections is to connect the neutral and ground circuit wires from the branch circuit to the neutral bar. These connections are made

convenient and easy to use. Other factors considered when selecting overcurrent devices are the wire size and amperage ratings, the electrical devices operated on the circuit, and the demand load of the circuit.

Correctly sized circuit protection devices must be installed. The main disconnect breaker determines the total electrical capacity of the SEP. These breakers are rated at 30, 40, 50, 60, 70, 90, 100, 125, 175, and 200 amps, with larger breakers available for industry purposes. The size of the service breaker will determine how much power is available; a 50-amp service breaker with 240 volts of power coming in will supply 12,000 (50×240) watts of power to the system.

Fuses and circuit breakers also have amperage ratings. Beginning at 15 amps, they increase by 5-amp increments up to 50 amps. Any overcurrent device used must have a amperage rating equal to or less than the rating for the conductor. For instance, an AWG 12 wire with an amperage of 20 amps would require an overcurrent device rated at 20 amps or less.

by stripping off enough insulation from the wires to make good contact with the neutral bar and then placing each wire under a different screw on the neutral bar, as shown in Figure 8.3. The screws should be tightened firmly. Next, the hot wire is attached by stripping off the insulation of the black wire and inserting the wire under the terminal screw of the circuit breaker, which should be screwed tight. Finally, the circuit breaker is inserted into the slot in the SEP board.

Connecting 240-Volt Individual Circuits to the SEP

Larger circuits that carry 240 volts utilize a special double-pole circuit breaker in the SEP. It has two connections because the circuit has two hot wires. To connect the wires, the black Another type of power supplied to agricultural structures is three-phase power, a form of alternating current. Single-phase alternating current provides power in a wave-like pattern, with periods of high amperage and low amperage as the current changes the direction of flow. Three-phase AC power utilizes three hot wires, each carrying electrical current at different stages of alternation; each wire peaks in amperage at a slightly different point in time. By synchronizing the wave patterns of the three hot wires, a more consistent amperage is achieved.

Three-phase power may be useful in some situations. Three-phase motors may be less

circuit wire is first connected to one terminal screw of the double-pole breaker. The white circuit wire is then connected to the other terminal screw. Finally, the ground wire is attached to the neutral bar. Figure 8.3 illustrates this type of circuit.

Three-Phase Power

expensive than single phase motors with the same horsepower. Three-phase power can also operate larger motors than standard single-phase power and will power those motors more efficiently.

Some limiting factors affect the use of three-phase power. The cost of three-phase power is higher than that for single-phase power because of the additional hot wire required. The power company must install additional transformers, which are devices used by power companies to raise or lower the voltage of alternating current for use in the home or business. A more expensive meter is needed to monitor power usage.

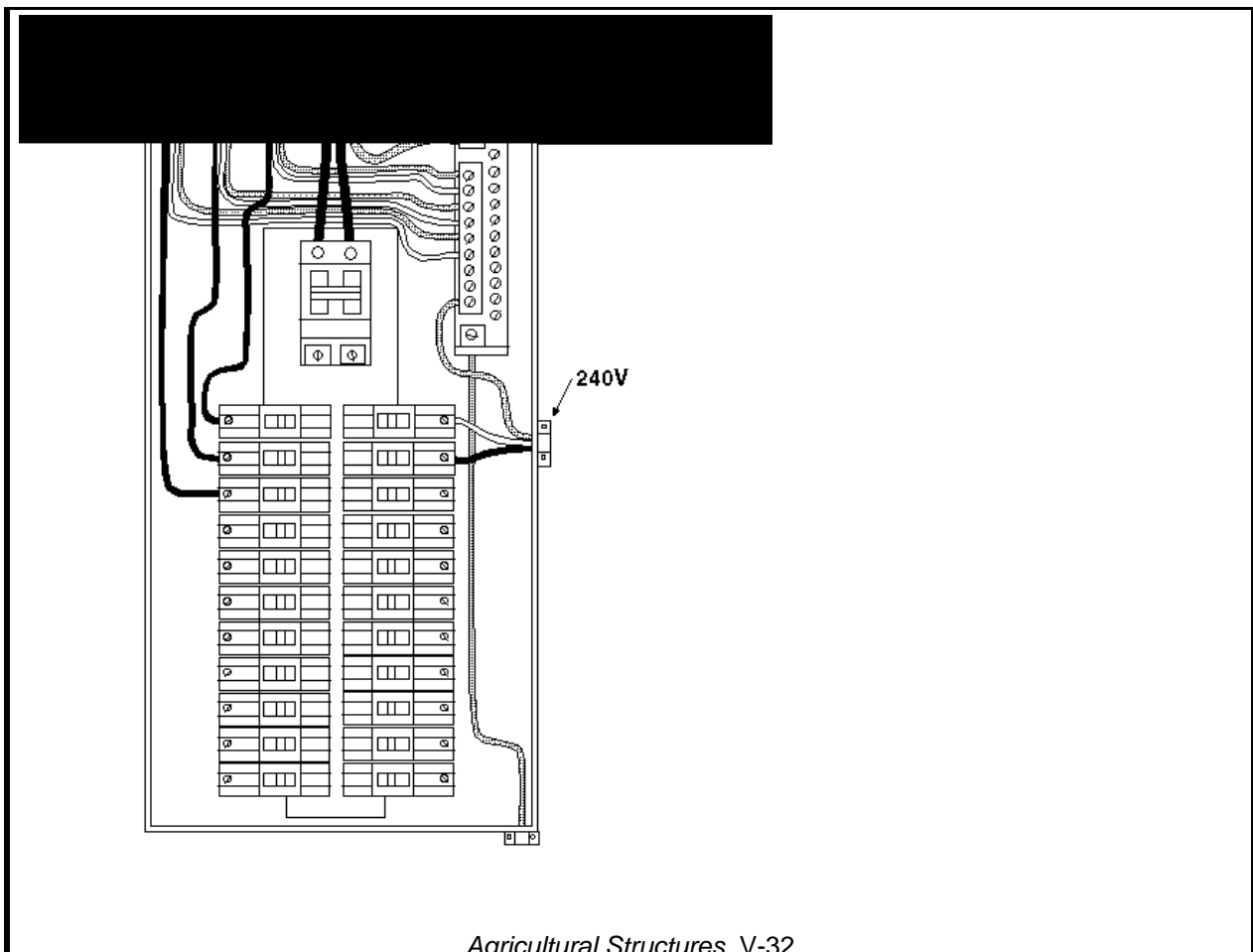

If three-phase power is desirable, it may be installed if it is not already available, or a phase converter may be used. A phase converter is a specialized device that allows a three-phase motor to operate using single-phase power. Phase converters can be very expensive, so an analysis of power needs should be conducted to determine if the investment is necessary.

Three-phase power is different from single-phase power in terms of wiring. Typically, the wire sizes are similar, but virtually all three-phase power circuits are hard wired, which means that three-phase outlets do not exist. Machines that require three-phase power do not have a plug at the end of a cable. Instead, the wires coming out of the machine are connected directly to the wires at the breaker box. This practice prevents single-phase machines from being plugged into three-phase outlets, which would burn out the motor.

Summary

The SEP is the point from which power is routed throughout an agricultural structure. A properly installed SEP is critical to providing an efficient electrical system for the structure. Wiring the service entrance conductors and the circuits properly is vital. The SEP should also be grounded correctly. The SEP houses individual circuit protection in the form of overcurrent devices, which should be carefully selected and installed to meet the needs of the structure. If three-phase power is to be used, it should also be installed with care.

Credits

Hiatt, Richard S., ed. *Agricultural Wiring Handbook*. 11th ed. Columbia, Mo.: National Food and Energy Council. 1996.

Holzman, H.N. *Modern Residential Wiring*. South Holland, Ill.: Goodheart-Willcox Company, Inc., 1986.

Richter, H.P., and W. C. Schwann. *Wiring Simplified*. 38th ed. Somerset, Wis.: Park Publishing, Inc., 1996.

Lesson 9: Running Wire from the SEP

Lesson 9: Running Wire from the SEP

Once the electrical power has been directed from the yard pole into the service entrance panel, it is time to consider the proper procedures for wiring the agricultural structure and connecting power to the switches, lights, and convenience outlets. When initially planning the wiring of the structure, determining the number and type of circuits that will be established in the building is important.

Location of the SEP

As discussed in Lesson 6, the NEC requires that the SEP be as close as practical to the point where the wires enter the building. It should also be located near equipment that has a high electrical draw, such as water heaters or large motorized equipment. This practice will reduce the costs of wiring by shortening the length of the run for larger wire sizes. It will also reduce voltage drop.

The SEP should be in an easily accessible location for three reasons. In an emergency, someone must be able to shut off power immediately. Also, ease of access to the panel is necessary if fuses blow or breakers are tripped. Finally, an easily accessible panel makes it easier to add circuits to the system.

Determining the Route of Each Circuit

When the SEP is in place, the route of individual branch circuits can be planned. Because many different circuits may be used to control different

outlets, lights, and pieces of equipment, carefully planning the path of each electrical circuit is important.

Two types of electrical circuits are considered when making a wiring plan. General circuits are those circuits carrying 110-volt current and normally containing more than one electrical device. Individual electrical circuits carry 220 volts of current and typically operate a single piece of equipment. Determining which type of circuit will be used and where the electrical devices will be placed within the structure is necessary. Remember, the placement of the SEP is partially determined by where the individual circuits with their heavier electrical loads will be placed.

The next consideration is which outlets will be connected to which circuit at the service entrance panel. A good rule of thumb is to avoid placing all the light fixtures in the same room or building on one circuit. With them all on a single circuit, if the overcurrent device that controls the lighting is triggered, the building or room will be in the dark, which may make it difficult to correct the problem. The amount of electrical load placed on convenience outlets will determine their circuit needs. If the outlets in a room or building will have low usage, with one to two outlets used at any given time, these outlets may be placed on a single circuit. If more than two outlets will be used at once or equipment with a high electrical draw will be used on a regular basis, the outlets should be split up on different circuits. Detailed planning can help avoid problems with blown circuits.

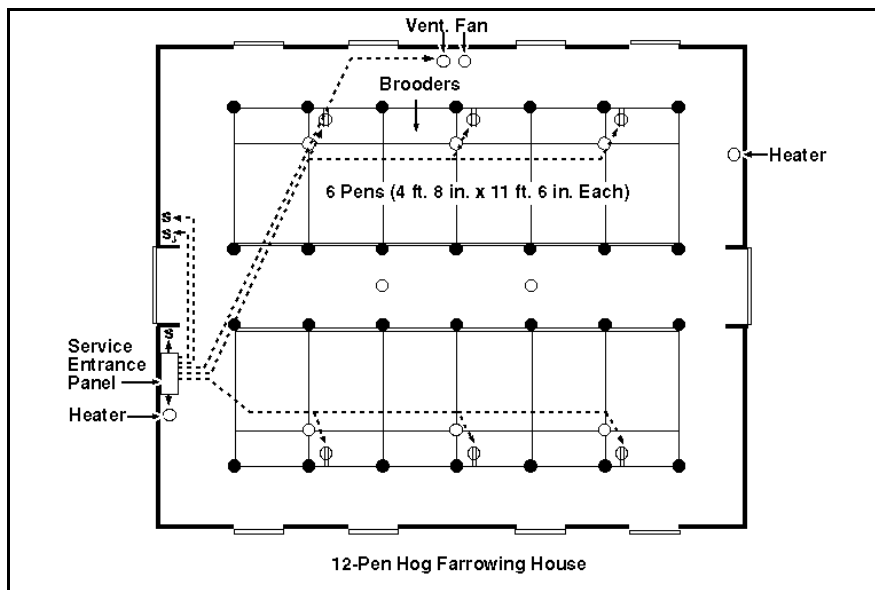

A wiring diagram (Figure 9.1) is useful when planning where branch circuits will run and what electrical devices will be connected to them. On the diagram, the entry point is marked first. The entry point is the point on the circuit where the wire attaches to the first electrical device on the circuit. The next step is adding up the number of devices on the circuit and making sure sufficient amperage can be supplied. This process is repeated for each circuit.

Electricity

Next, outlet boxes for lights and receptacles are physically mounted at each location. They are labeled on the diagram and within the structure for easy reference. A code system based on the circuit used makes it easy to connect electrical wiring to the appropriate circuits and outlets. Figure 9.2 shows an example of circuit identification. One coding method involves using Roman numerals (I, II, III, etc.) for the individual circuit line. Letters (A, B, C, etc.) designate the different outlet boxes. Switches are labeled with an S; if three-way switches are used, they are labeled S1 and S2. All outlet boxes and switches should be labeled prior to installing any wire for the branch circuits.

Running the Wires

Once the labeling is complete, wires can be run in the structure. Protecting the wire is an important consideration. Excessive bending of electrical conductors should be avoided to prevent the insulation from cracking, which could cause the wire to short out. Also, wire is run inside of walls and ceilings to prevent physical damage to the wires. Any exposed wire runs or runs where damage may be a concern, such as in walls where moisture damage could occur, should have the conductor placed inside of a conduit.

Placing electrical runs in the walls is also common. Four approved methods are used to place electrical conductors within a wall; they are illustrated in Figure 9.4. The first method

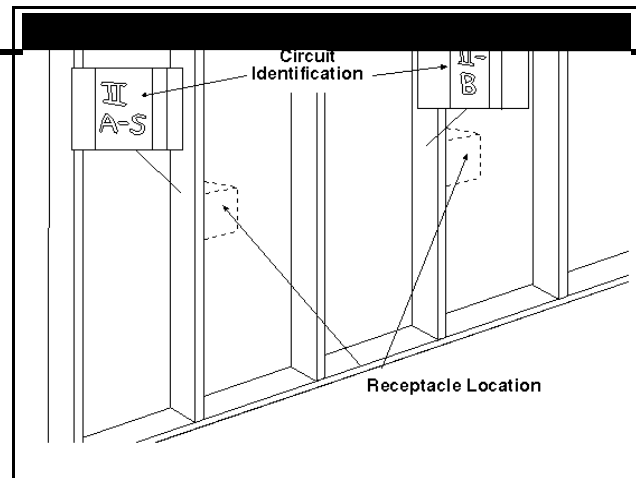

A few general practices should always be followed when running wire in a structure. Conductors should run as straight as possible from the SEP to the individual outlets. To reduce the possibility of system failure, as few splices as possible should be used. Wire runs should be as high and dry as possible.

Conductors may be run through the floor or ceiling. Ceiling runs are best because damage from traffic is minimized. They also reduce wire damage because the wires are not located where water may collect or flow. Examples of ceiling runs are shown in Figure 9.3. If runs must be under flooring, noncorrosive conduits should enclose the wires.

requires the drilling of a hole in the center of the wall studs. The hole should be large enough to accept the conduit or to allow the cable to slide through easily without friction and binding. Wire

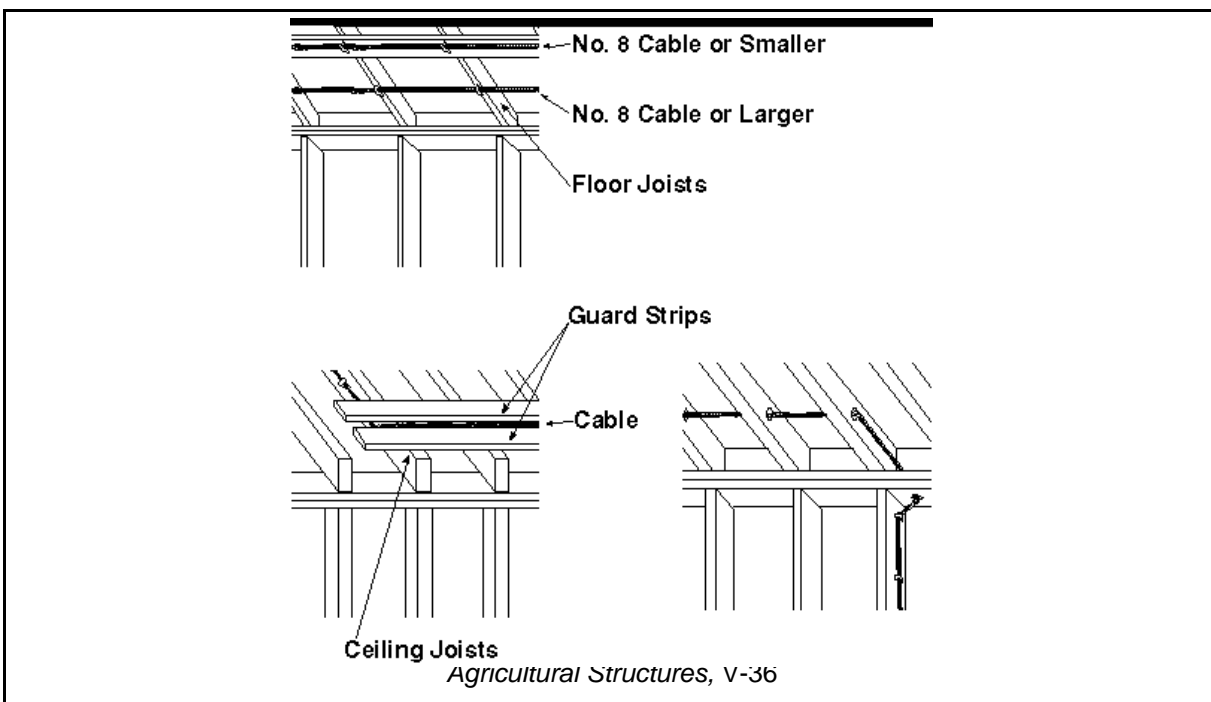

Lesson 9: Running Wire from the SEP

can also be stapled along the side of a stud. A third method of running wire involves cutting a notch in the side of the wall studs. A steel cover plate is installed over the notch after the wire is in place. In structures where moisture will not be a factor, wire can be run in the walls by notching the bottom of the studs and running the wires along the bottom plate of the wall. This last alternative lessens problems with installing insulation later.

Tools for Wiring a Receptacle or Light

Gathering all the necessary tools is an important first step before installing anything. As with any construction task, the use of the proper tools is essential to working safely and efficiently.

Numerous tools can be used in electrical wiring. However, a few essential tools must be on hand to do a good job with installations.

- Wire cutters, either lineman's pliers, side cutting pliers, or needlenose pliers

- Cable rippers, which is used to remove the cable covering from the conductors housed in the cable sheathing
- Wire strippers for removing insulation from conductors
- A complete set of screw drivers
- Hammer
- Slip-joint pliers
- Level
- Tubing cutter for cutting conduit
- Conduit bender, which is used to bend or form conduit to turn corners

Other tools can also be used to accomplish wiring tasks more efficiently. They include the following:

- Socket wrenches
- Drill motor and drill bits
- Adjustable open-end wrench
- Hand saw
- Electrical testing equipment

The Function of a Junction Box

When wiring circuits, branching the circuit is sometimes necessary. Branching is splitting

the circuit to allow power to run in two or more directions. A junction box is used to protect the wires that are spliced together to branch circuits. Junctions are sometimes needed if a long

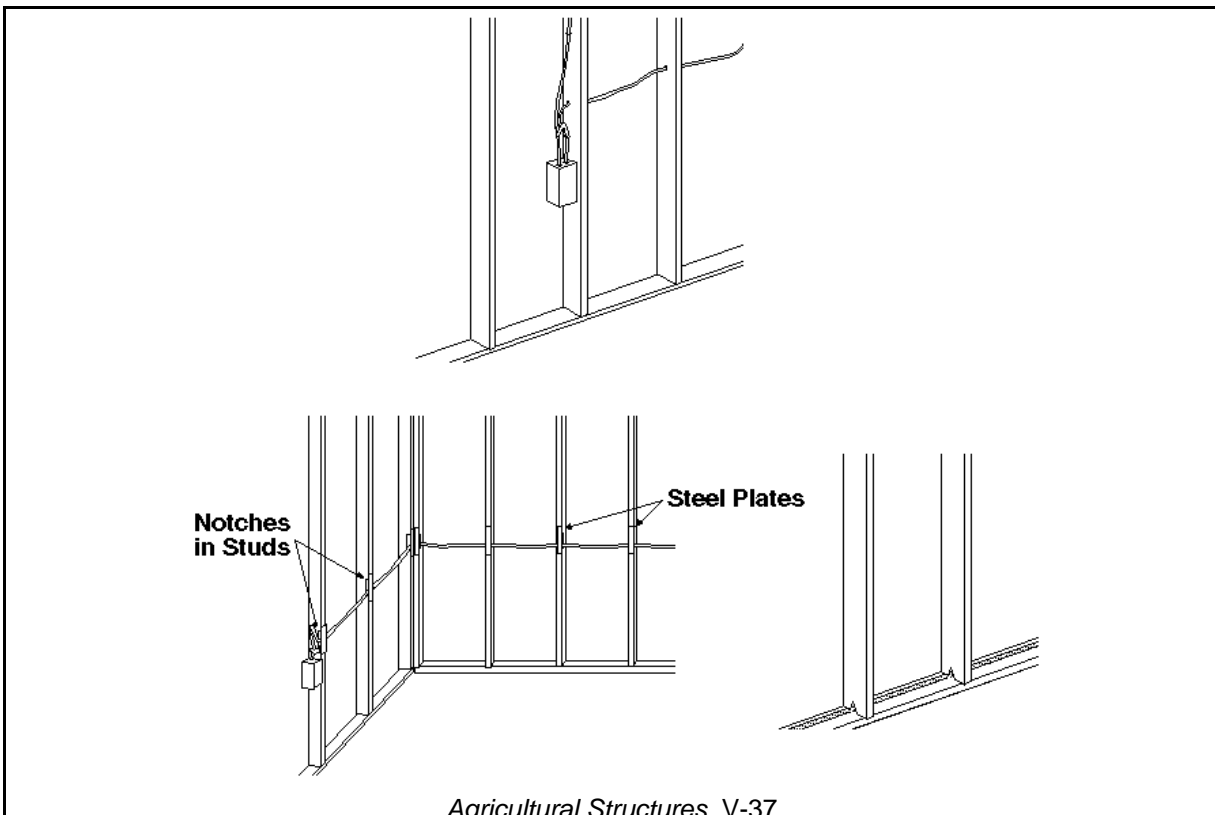

Electricity

electrical run is required or if no convenient outlets are available from which to branch power to different outlets on the same circuit.

A junction box is basically an outlet box with a solid cover. The NEC states that all boxes in which splice connections are made must be dust tight and watertight. The NEC also requires that they be made of corrosion-resistant material.

Junction boxes should be located where they are permanently accessible for repairs.

Connections in a junction box should be made carefully, paying attention to detail. The ends of the wires are inserted into the junction box through the knockouts, which are specially designed parts of the junction box that can be removed. About 6 inches of each wire should pass through the knockouts. When splicing conductors together, black wires are connected to black wires, white wires to white wires, and ground wires to ground wires. If the outlet box is metal, a separate piece of wire should be connected to the box and the ground wires. The wires should be clamped securely to the box to prevent the splices from pulling apart. A junction box is shown in Figure 9.5.

Techniques for Splicing Wires

For most electrical wiring, solderless connectors are used to splice wires. Several different types of solderless connectors are used, including threaded metal insert connectors, removable metal insert connectors, and spring-loaded connectors. These connectors are pictured in Figure 9.6. They all perform the same basic function of efficiently joining two or more wires.

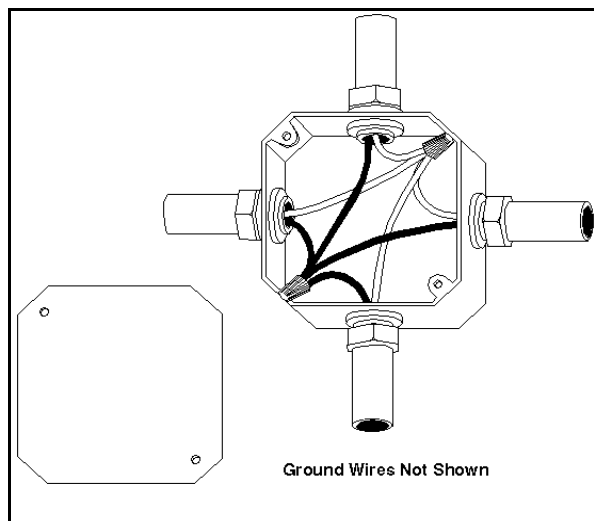

Insulated solderless connectors, commonly referred to as wire nuts, are easy to use. To splice wires, the wire insulation is stripped back just enough for the wires to fit inside the connector. The wires are then laid together. The method for connecting the wires depends on the connector selected. With the threaded metal insert connector, where the insert is

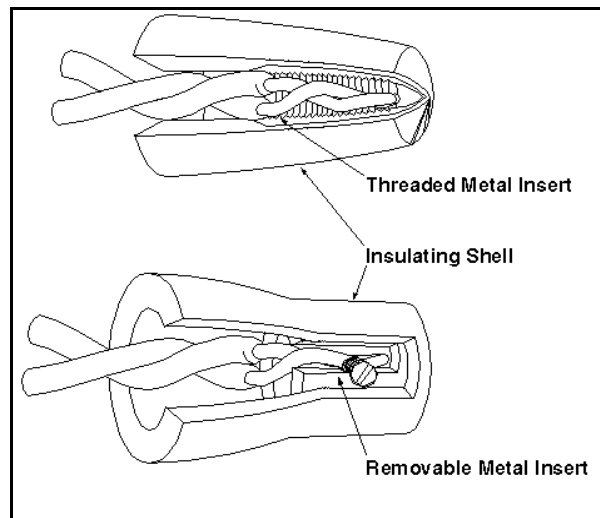

contained in an insulating shell, the connector is screwed onto the wires to be joined. For the removable metal insert connector, the insert can be removed from the insulating shell. The insert slips over the wires, and the set screw in the insert is tightened to lock the wires in place. The insulating shell then screws back on over the insert. The spring-loaded connector is similar to the threaded metal insert in that it screws onto the wires to be spliced. Inside of the insulating shell is a cone-shaped spring that holds the wires together when screwed onto the wires.

Lesson 9: Running Wire from the SEP

When using solderless connectors, taping the conductors may be necessary. If the correct amount of insulation has been removed, tape is not needed because the insulating shell of the connector will protect the bare wires. However, if bare wires are exposed, electrician's tape is wrapped around the connection to protect the wires.

When splicing wires that are AWG 8 and larger, different connectors are needed. For these situations, metal connectors are used. They have a collar with a set screw. To splice wires, the wires are inserted into the connector, and the screw is tightened to hold them in place. The connector and wires are wrapped with electrician's tape to protect the joint.

Wiring a Light Circuit

Almost every structure that has electrical power will have some form of lighting. Understanding the principles behind the proper wiring of lights and switches is necessary to efficiently and correctly connect these circuits.

Wiring a switched circuit, as shown in Figure 9.7, is relatively simple. White, black, and ground wires enter the switch box from the power source. The white source wire is connected to a white

Before wiring any type of light circuit, the wires must be inserted into an outlet box. Six inches of the insulation is removed before inserting the individual wires into the box. Box connectors, or special connectors that attach to the electrical box and clamp the conduit in place, hold the wires in place as they enter the box.

The most basic light circuit is the simple circuit. For this circuit, the black hot wire connects to a brass screw on the light fixture. The white neutral wire connects to a silver screw. The electrical flow through the fixture and the attached lamp provides light. This system is impractical because the light cannot be turned on and off.

A switched circuit allows a light to be turned off. In a switched circuit, a switch breaks the electrical circuit of the light fixture. When the switch is open, it interrupts the flow of electricity and turns the light off. When the switch is closed, electricity flows through the circuit, creating light.

wire with a connector. The black source wire is connected to a brass screw on the switch. Another black wire is attached to the other screw on the switch. At the light fixture, this black wire

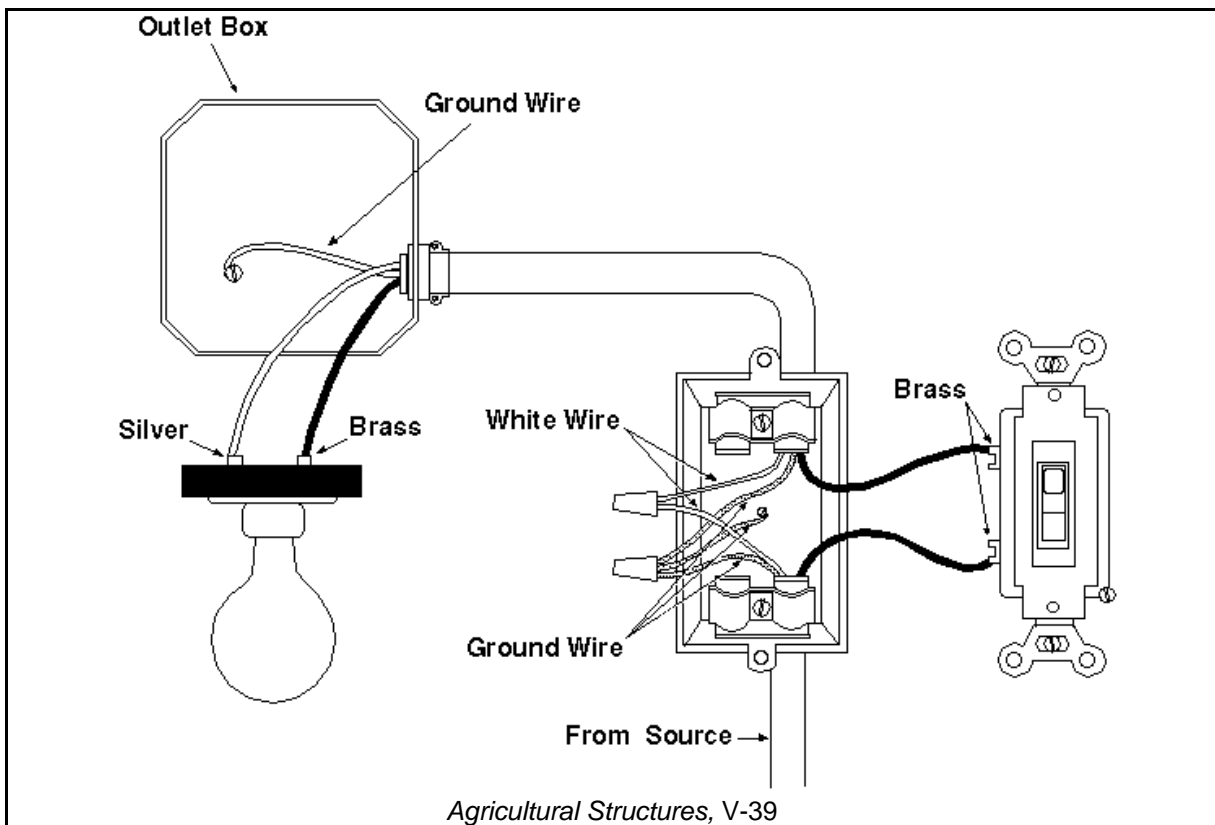

Electricity

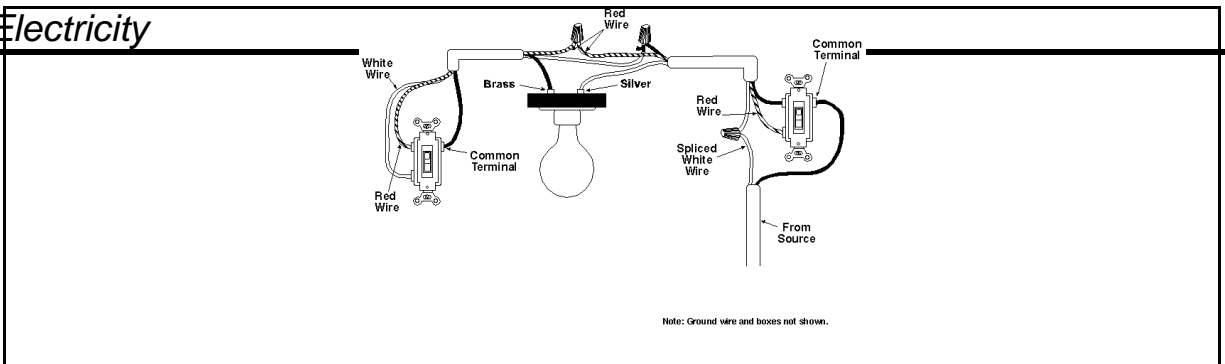

is connected to a brass screw and the white wire to a silver screw. A green ground wire from the light fixture is connected to the ground wire from the source using a solderless connector. If the boxes are metallic, the ground wires are attached to the boxes with a piece of wire.

In a switched circuit, the power may be brought from the source to the light fixture box rather than to the switch. A switch loop is used to carry the electricity to the switch. In a switch loop, a pair of black wires brings the power to the switch from the lighting box and carries it back to the light, as illustrated in Figure 9.8. The black source wire is connected to a length of black wire with a connector. This wire is connected to a brass screw on the switch. Another black wire is connected to the other brass screw on the switch. This second black wire runs back to the lighting box. It is attached using a connector to a black wire from the brass screw on the fixture. The white source wire is connected to a white wire from the light fixture using a connector. The white wire is attached to a silver screw at the light fixture.

The wires from the two switches meet at the light fixture. The black wire from the first switch is connected to the white wire from the second switch using a solderless connector. A connector is also used to splice the red wires together. The black wire from the second switch is attached to the brass screw on the fixture, and the spliced white wire from the power source is connected to the silver screw. A completed three-way switch is pictured in Figure 9.9.

Series and parallel wiring are two methods used for wiring two or more light receptacles together. These methods are used when more than one

A three-way switch controls another type of lighting circuit. Using a three-way switch, a light can be turned off and on from two different locations. The wiring requires the use of a three-wire cable with black, white, and red conductors plus a ground wire.

Wiring a three-way switch begins at one of the switches. The black wire from the power source is connected to the common terminal on the switch, which is the side of the switch with one terminal screw. A black wire is connected to the switch on the opposite side from the black source wire. A red wire is connected to the other terminal on that side. The white wire from the source is spliced to another white wire with a solderless connector. Appropriate ground connections are made at the switch.

Next, the other wires are connected at the second switch. A black wire is connected to the common terminal of the switch. A red wire is attached to the terminal opposite the black wire, and a white wire is connected to the other terminal. The ground connections are then made in the box.

light fixture is on a circuit. They are illustrated in Figure 9.10.

Series wiring is an impractical system except for special purposes because the way the outlets are connected, if one light goes out, they all go out. Series wiring is primarily used in situations where a burned out light needs to be addressed immediately. To install a series system, the black wire from the source is attached to a terminal on the first fixture. A white wire then runs directly from the second terminal to the next lighting fixture and attaches to a terminal there. Another black wire runs from the second terminal

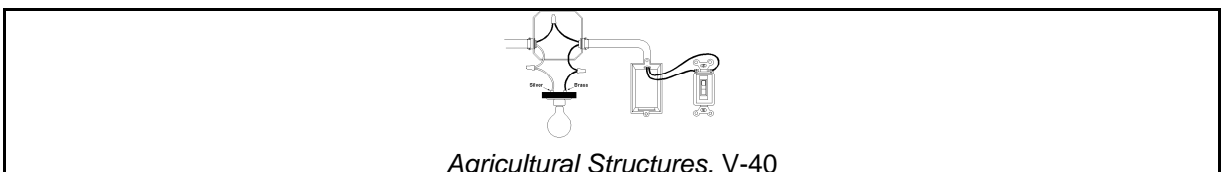

Lesson 9: Running Wire from the SEP

on that fixture directly to the next fixture. This pattern continues through the series. If one

Parallel wiring is the most common method of wiring multiple light fixtures. In parallel wiring, jumper wires attached to each light fixture are spliced to the white and black wires from the power source. This system allows power to flow separately to each individual lamp on the same circuit. If one lamp burns out, the other lamps will still receive power for lighting.

Wiring Convenience Outlets

Convenience outlets provide electrical connections for tools and equipment. Therefore, wiring them properly in the electrical circuit is necessary. Outlet receptacle devices are easy to install and can be connected in a series. These receptacles can be controlled with switches.

Wiring a receptacle circuit begins with attaching the black source wire to the side of the receptacle with the brass screw. The white wire is attached to the silver screw on the opposite side of the receptacle. The ground wires are joined using a connector. A wired receptacle is illustrated in Figure 9.11.

The procedure for wiring two or more receptacles on a circuit is more complicated. The first receptacle is connected as described.

lamp burns out, it breaks the circuit, thus cutting off electricity to all the lights on the circuit.

Another black wire is then connected to the other brass screw on the first outlet and to the brass screw on the second receptacle. A white wire is connected to the second silver screw on the first receptacle and the silver screw on the second. The same procedure is followed for any other receptacles on the same circuit. The appropriate ground connections should then be made.

Summary

Planning the location of circuits and equipment to be installed is useful. Not only does a wiring diagram identify how electrical runs will be laid out but also where electrical outlets will be installed. Once the plan is finalized, the proper tools to do the job should be gathered together. Lights and receptacle outlets can be then be installed using the proper techniques.

Credits

Holzman, H.N. *Modern Residential Wiring*. South Holland, Ill.: Goodheart-Willcox Company, Inc., 1986.

Mix, Floyd M. *House Wiring Simplified*. Tinley Park, Ill.: Goodheart-Willcox Company, Inc., 1996.

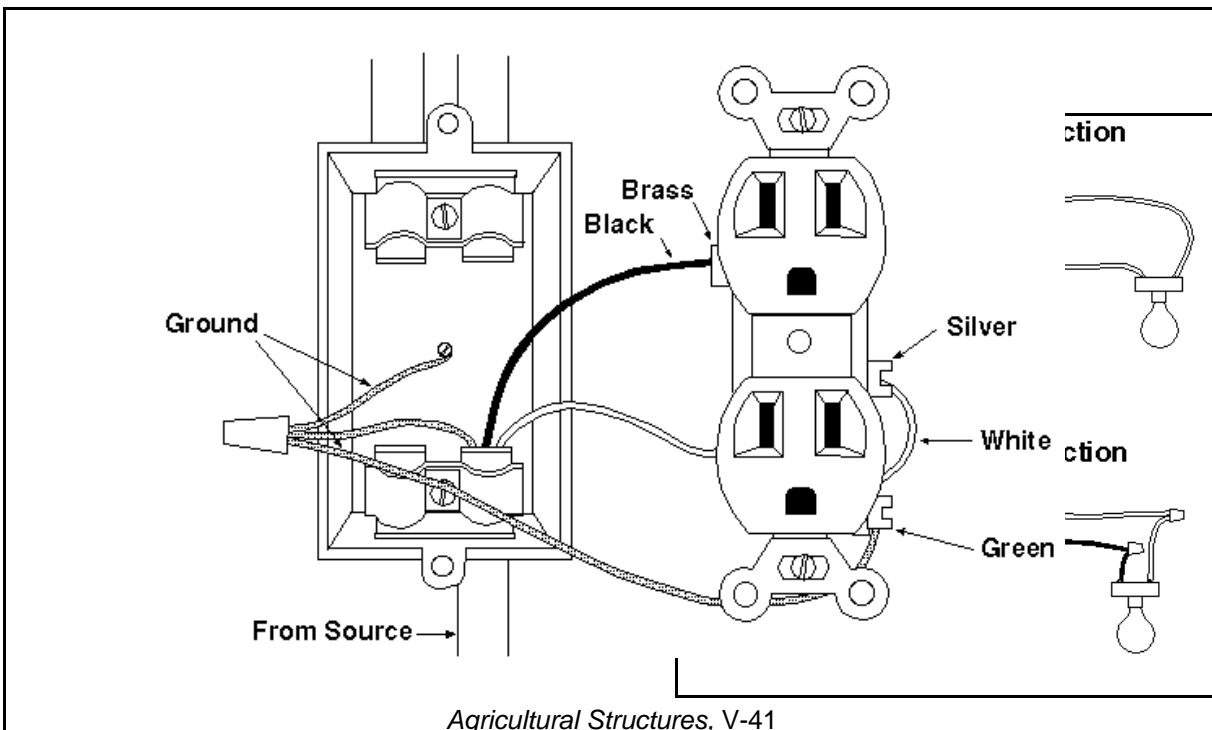

Electricity

Richter, H.P., and W. C. Schwann. *Wiring Simplified*. 38th ed. Somerset, Wis.: Park Publishing, Inc., 1996.

Lesson 1: Water Needs

Water is critical to most agricultural operations. Calculating the volume of water needed and determining suitable sources of water is one of the responsibilities of a farm planner. These questions may be difficult to answer precisely. However, suitable estimates are necessary to ensure that an agricultural operation can function effectively.

Sources of Farmstead Water

Water for agricultural operations is generally available from a variety of sources. The most common artificial sources are public water services, wells, and cisterns. Public water supplies generally provide a safe, dependable water supply, but this water source is not available in all areas, making private water sources necessary. Wells can provide a large quantity of safe water with relatively little maintenance. Underground wells may be either shallow or deep. Shallow wells will give sufficient water, but the quality of water will be poorer, because the water is not filtered through as much soil for purification. Deep wells will have cleaner water and usually contain a larger volume of water, although they are more expensive to drill. Cisterns can store rainwater for domestic use but may not supply enough for livestock.

Ponds may be natural or man made. They often supply livestock with water and, with the proper construction and purification, can be used for humans as well. Protection from pollution can be a problem.

Natural sources of water, such as creeks, streams, and springs, are also useful to farm operations. However, they may not be able to provide enough water to meet the needs of the operation. Also, flooding, droughts, and the changing topography of water courses can make these sources of water unreliable for most irrigation and animal needs. Operations that utilize natural sources of water must be flexible enough to operate successfully in a variety of conditions.

The construction involved in developing some water sources, such as wells and ponds, is beyond the scope of the average producer and

requires the assistance of knowledgeable professionals. Further information about wells and ponds is available from local University Extension offices.

Selecting the correct water source for an operation involves a number of different factors. The water sources already available, the uses of the water, and the costs of developing new sources should all be considered. Underground wells are the preferred water source for human consumption, but water for animal needs, irrigation, cleaning, and other uses can be from ponds, rivers, reservoirs, and other sources because the quality is not as important. The major exceptions to this rule are dairy operations and large hog operations, where high quality water is preferred. These types of operations require optimal water quality to maximize production.

Water Uses on a Farmstead

The uses of water from these various sources will depend on the type of agricultural production taking place. A few uses of water that are essential to many enterprises are drinking water for livestock, water for irrigating crops, and water for sanitation. Another common use of water is for cooling systems in some types of facilities, such as greenhouses or hog facilities. Water can also be utilized as a delivery system, by adding fertilizer to water while irrigating or medication to the animals' drinking water. If a home is located on the farmstead, water will also be used by humans for various domestic purposes.

Determining Total Daily Water Need

The exact amount of water required for the different uses of agricultural operations would be very difficult to calculate, because conditions that affect water needs, such as temperature and humidity, change regularly. However, the total amount of water normally required to meet the daily needs of an operation can be closely estimated. The first step in making this estimate is finding information on water needs. Charts that show the water needs for different types of animals and crops or special circumstances have been developed to help estimate needs. Table 1.1 shows a sample water needs chart. Sources of information about water needs include local University

Table 1.1 - Water Needs Table

Plumbing	Water Needs
Adult human	50 to 100 gallons per day
Beef animal	8 to 12 gallons per day
Milk cow	35 to 45 gallons per day
Dry cow	20 to 30 gallons per day
Calf	6 to 10 gallons per day
Swine (finishing)	3 to 5 gallons per day
Sow and litter	8 gallons per day
Horse	12 gallons per day
100 chickens (laying)	9 gallons per day
Lawn and garden	600 gallons to apply 1 inch of water on 1,000 square feet of area
Flushing floors	Minimum of 10 gallons per 100 square feet of floor

Extension offices and trade associations, which may be the best resource for more specialized products.

Once information on water needs for a particular operation has been collected, the total daily water need of the operation can be determined. The first step is multiplying the recommended amount of water for a particular use by the amount of usage; for example, the amount of water needed for a beef animal is multiplied by the number of animals in the herd to find the total amount of water needed for a beef cattle herd. The different water uses are then added together to find the total daily need of the operation. Overestimating the amount of water needed and planning for that amount is better than not having enough water. Keeping accurate records of the amount of water used and what the uses were over a period of a few years will yield very accurate data for future water use projections.

Some producers may wish to take fire protection into consideration when estimating water needs, in addition to the normal needs of the operation. If water for fire protection is desirable, a minimum of 1,200 gallons (at 10 gallons of water per minute for two hours a day with a pressure of 30 pounds per square inch) is required. Twice this amount, or 2400 gallons (20 gallons per minute at 60 pounds of pressure per square inch for two hours per day), would be even more effective.

Determining Peak Water Need

After estimating the total daily water needs, the peak water needs for a farmstead can be determined. The volume of water a water source can deliver is usually measured in gallons

per hour. The total daily needs should be compared with the hourly output, which should be greater than the daily needs of the operation in order to meet peak water needs. Having a water system that can meet the peak need will be sufficient to supply the operation under most circumstances.

Summary

Water is indispensable to production for agricultural operations. The water may come from a variety of sources, including wells, ponds, and springs. It also has a variety of uses, such as drinking water for livestock, water for irrigating crops, and water for sanitation. While determining the exact amount needed to operate may not be possible, accurate estimates of the total daily water needs and peak water needs can be made and used in planning water systems.

Credits

Annis, William H. *Basic Plumbing Skills*. Athens, Ga.: American Association for Vocational Instructional Materials (AAVIM), 1989.

University Extension agricultural publications, University of Missouri-Columbia.

G1800: Sources for Farm and Home Water Supply

G1801: How to Size a Farm and Home Water System

Lesson 2: Plumbing Safety

Given the need for water in agricultural operations, good plumbing systems are a requirement. Although few people think of plumbing as dangerous, some dangers do exist when working with pipes and fittings. Therefore, using the proper tools and methods is important for safety.

Hazards of Plumbing

Plumbing may involve working in open trenches that range in depth from two to ten or more feet deep. If the trench is deep enough, people can suffocate if the sides cave in and bury them. The sides of any deep trench should be carefully observed for signs of instability, such as loose and collapsing areas. These areas should be avoided until they have been excavated to a safe point. Another situation that requires caution is if heavy excavating equipment is close to the sides of a trench, since the equipment can cause the earth to cave in. The equipment should be removed before anyone enters the area.

Plastic pipes require the use of cleaners and cements, or glues, that contain strong chemicals.

These substances can be hazardous because they may produce very strong, sometimes toxic, fumes, making good ventilation a necessity. They may also irritate the skin and be flammable.

Fire can be another danger when working with plumbing. In areas where septic or waste lines are present, methane gas may accumulate. This gas is flammable and can explode. Another potential fire hazard occurs when using a propane torch to join copper pipe. The flame can cause a fire if it comes into contact with combustible materials, such as wood, paper, and clothing. Remember, if plumbing is being installed, water for fire protection may not be available.

Disorganized, untidy work sites can cause accidents. Tripping and falling are common causes of injuries. Small sections of pipe left lying around can be particularly hazardous, since

Plumber	Plumbing supply dealer
Plumbing retailer	Plumbing inspector
Plumbing educator	Well driller
Plumbing contractor	
Plumbing estimator	

they tend to roll when stepped on. Ladders, which are used to place pipes overhead or in walls, can tip over if they are not set on a level, solid surface.

Tools for Safe Plumbing Practices

In the past, metal pipes, consisting of cast iron for drains and copper and galvanized steel for supply lines, were the industry standard. Tile was also a common material for drain lines or pipes. These materials may still be found in older structures, but, with the exception of copper lines (required by building codes under various conditions), they are not a popular choice for new construction. Plastic plumbing materials are much easier to work with and do not require the specialized tools that were necessary for working with their metal counterparts. Because of the decline in popularity of metal pipe, few people choose to invest in the tools necessary to work with it. These tools are quite costly and specialized in function, so they are simply not practical.

A few general tools are needed for plumbing practices. A shovel can be used to dig shallow trenches for pipe; for deeper trenches, heavy earthmoving equipment is necessary. Other tools needed when installing pipe are a level, a claw hammer for removing boards, a ladder, a tape measure, and a drill for drilling holes in walls to run pipes.

Working with plastic pipe requires some additional tools. They include a hacksaw for cutting pipe into smaller lengths and an adjustable wrench to hold plastic pipe fittings. Sandpaper, a knife, or a scraping tool is used to smooth the rough edges of pipe that has been cut, and pipe cleaner removes residue from cutting. Pipe glue is used to join pipes.

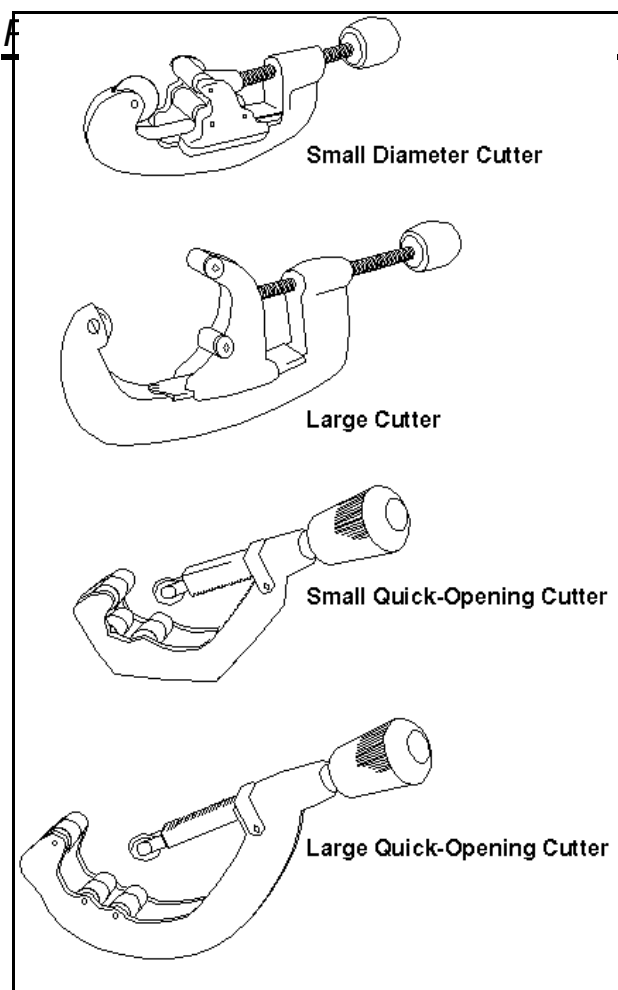

If copper pipes are necessary, special tools must be used. A propane torch and soldering material join pipes together. A pipe cutter cuts the pipe into lengths, while a pipe bender bends the pipe. A pipe reamer is used to remove

sharp edges after cutting the pipe. A flaring tool is used to widen the end of the pipe. Some copper fittings are designed to seal using compression, requiring that one end of the pipe be widened to prevent the fitting from sliding off. Figure 2.1 shows some different types of pipe cutters. Figure 2.2 shows one kind of bender and different flaring tools.

Using Plumbing Tools Safely

Protective clothing and gear can greatly enhance personal safety while using the plumbing tools listed. A minimum of heavy work pants, boots, gloves, and eye protection is suggested. If injury from above is possible, a safety helmet may be needed.

Most plumbing tools are safe if used carefully. All tools should only be used according to the manufacturer's recommendations. When utilizing plastic pipe cleaners and cements, special attention should be given to any safety recommendations concerning ventilation, skin contact, or fire hazards. If working with plumbing involves soldering copper pipes, using a propane torch will probably be necessary. Extreme caution should be used when working with a torch; proper ventilation and the use of the protective clothing and gear listed above are a must.

Plumbing, like other construction activities, requires that people be alert and cautious to stay safe. Workers must stay focused on the task at hand as well as their surroundings to avoid injuring themselves or others.

Summary

Basic plumbing skills are necessary for constructing many types of agricultural structures. Being aware of any possible hazards is an important part of working with plumbing materials safely. Safety can also be maintained by becoming familiar with the tools needed and how to use them properly. By following these guidelines, the chances of an injury or accident occurring can be greatly reduced.

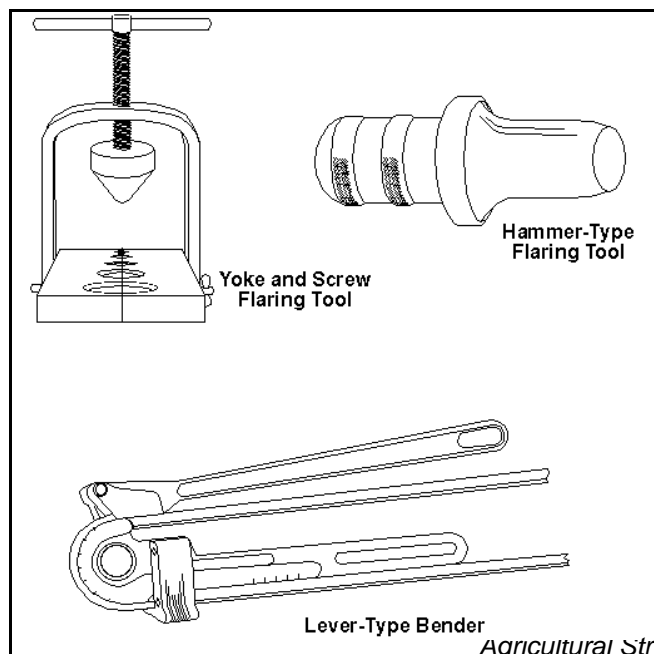

Lesson 2: Plumbing Safety

Credits

Annis, William H. *Basic Plumbing Skills*.
Athens, Ga.: American Association for
Vocational Instructional Materials (AAVIM),
1989.

Huth, Mark W. *Construction Technology*. 2nd
ed. Albany, N.Y.: Delmar Publishers, 1989.

Lesson 3: Pipe Types and Size Requirements

Lesson 3: Pipe Types and Size Requirements

As discussed in Lesson 2, both plastic and copper pipe is available for plumbing. These two types of pipe come in several varieties and sizes. Installing plumbing involves not only choosing the best type of plumbing for a particular purpose, but also choosing the correct pipe size. The size of the pipe must be adequate to deliver the required amount of water at the proper pressure.

Pipe Types and Characteristics

Plastic pipe is the most popular plumbing material for agricultural structures. This type of pipe is durable and readily available in various forms and diameters that will meet practically any plumbing need. It is less expensive than copper pipe. Plastic pipe is also easier to work with and requires few specialized tools or skills. However, plastic pipe does have a few disadvantages. It is brittle and more easily broken at low temperatures. Also, plastic pipe is crushed more easily than harder metal pipes.

Five basic types of plastic pipe are available: Polyvinyl Chloride (PVC), Chlorinated Polyvinyl Chloride (CPVC), Acrylonitrile-Butadiene-Styrene (ABS), Polyethylene (PE), and Polybutylene (PB). Each type of plastic pipe has a unique chemical composition that affects its suitability for a given situation.

Polyvinyl Chloride - PVC is the common rigid white plastic pipe seen around construction sites.

The pipe size most generally used is either 1 inch or $\frac{3}{4}$ inch in diameter; the pipe comes in lengths of 10 to 20 feet. It is used for cold water supply and waste disposal lines. This material is not recommended for hot water because of its chemical composition.

Chlorinated Polyvinyl Chloride - CPVC is similar to PVC pipe, but it is off-white or cream in color and is recommended for temperatures up to 180 degrees Fahrenheit. This pipe is most commonly found in $\frac{1}{2}$ - to $\frac{3}{4}$ -inch diameters and 10 foot lengths. CPVC is a common choice for hot water lines. Although CPVC will work for cold water supply lines, it is seldom used for this purpose because it is more expensive than PC

pipe and because using similarly colored pipe for hot and cold lines can become confusing when installing or repairing lines.

Acrylonitrile-Butadiene-Styrene - ABS is a hard black plastic pipe used mostly for drain and sewer lines. It is commonly available in sizes ranging from $1\frac{1}{4}$ inches to 6 inches in diameter and in lengths of 10 to 20 feet.

Polyethylene - PE is a flexible black plastic tubing that comes in coils from 100 to 300 feet in length. It is available in diameters of $\frac{3}{4}$ inch to 2 inches. Since it cannot withstand heat, PE is only useful for handling cold water. PE is primarily used for installing underground water service lines.

Polybutylene - PB is a flexible plastic pipe, usually gray in color, that is available for use with cold or hot water. It is most commonly $\frac{1}{2}$ inch or $\frac{3}{4}$ inch in diameter. PB has the advantage of being flexible enough to go around corners or objects without having to be cut and joined together with fittings. For this reason, it is useful in place of copper for fixtures such as sinks or toilets. Polybutylene pipes have been problematic, however; they have been prone to leaks, especially around fittings. Manufacturers are attempting to correct this problem with new types of connectors.

The other type of pipe most frequently used for plumbing is copper. Copper pipe is very durable. The pipe is not difficult to work with, but it does require more skill and specialized equipment to perform tasks like soldering joints and fittings. The main disadvantage of copper pipe is its cost; the pipe is more expensive than plastic pipe. Thicker pipe contains more copper and is more costly, although it is also more durable. The pipes are available in two forms, hard and soft copper; hard copper pipe is rigid, while soft tubing is flexible. Depending on the type of pipe, copper pipe is available in sizes of $\frac{1}{4}$ inch to 12 inches in diameter. Hard copper generally comes in 20-foot lengths, while soft copper comes in coils varying in lengths from 45 to 100 feet. Pipes come in four weights: K, L, M, and DWV.

K - This pipe has the thickest walls of the four types. It is available in hard and soft copper forms. For the purposes of identification, K is

Plumbing

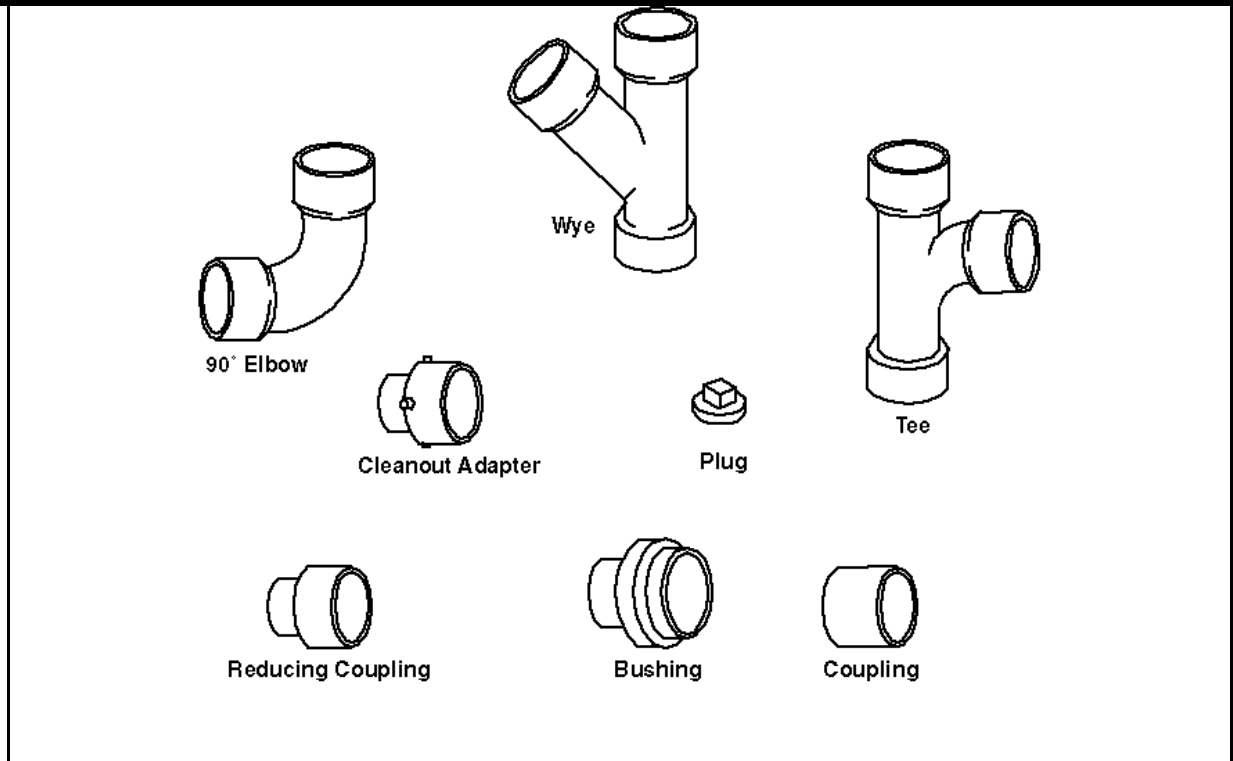

color coded green. The pipe is used for

underground supply lines.

L - This type of pipe is slightly thinner than K and is available in hard or soft forms. Its color code

is blue. Type L must be used above ground; it is used for general interior work.

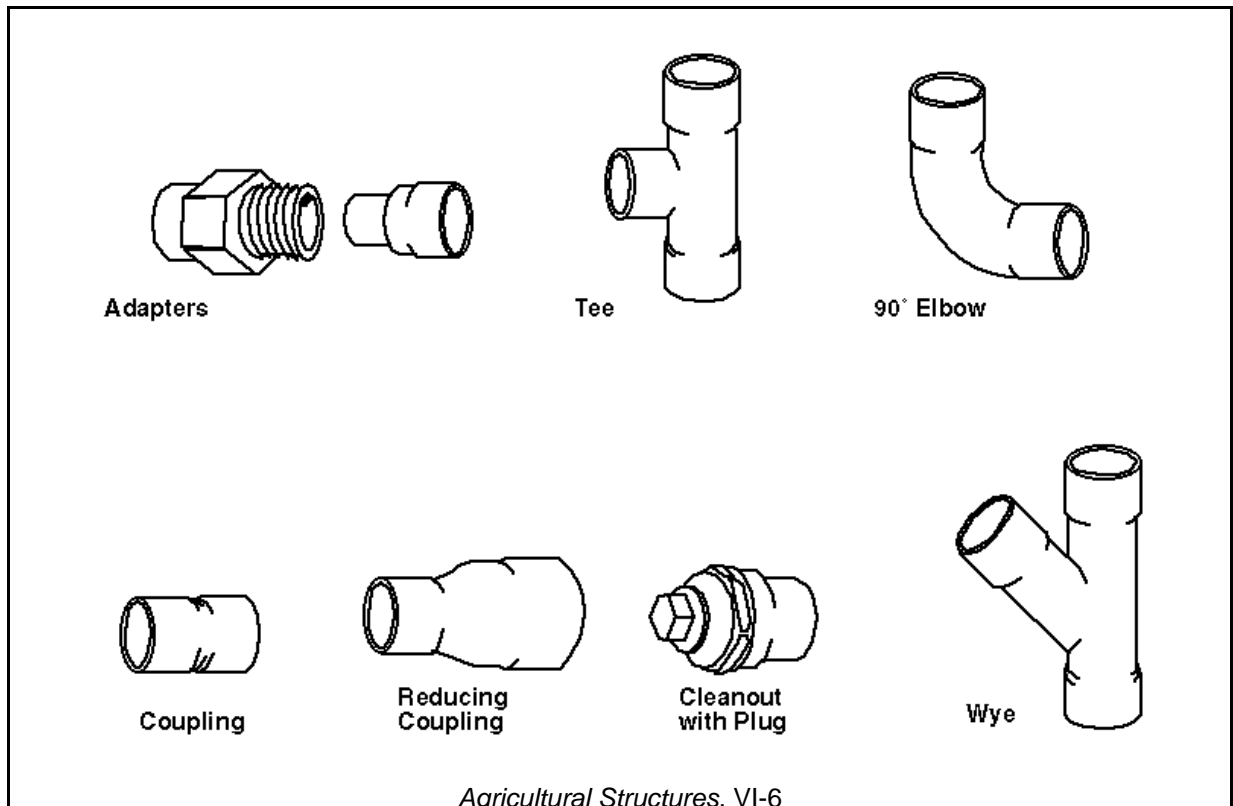

Plumbing

M - Type M is slightly thinner than L. It is available in hard form only and is color coded red. Common uses are for above ground interior water supply, waste, or drainage lines.

DWV- DWV is the thinnest of the four types of copper pipe and is available only in the hard form. It is color coded yellow. This type of pipe is used above ground for drainage, waste, or vent (allowing gases in a waste line to escape) pipes.

Pipe fittings join pipes together and allow them to branch, change direction, be reduced in size, or be capped. Fittings called elbows allow the pipe lines to make 45 or 90 degree turns. Couplings join two sections of pipe of the same size. Reducers connect pipes that differ by one size, such as a ½-inch pipe and a ¾-inch pipe. Bushings reduce the size of the opening in a large pipe into which a smaller pipe passes; in contrast to reducers, they allow a broader range of pipe sizes to be joined and can be used with larger pipe sizes. A tee is a branch fitting that makes a 90 degree turn; a wye makes a 45 degree turn. Cleanouts are fittings that allow entry into the pipe line in the event a clog occurs.

End caps block off the end of a pipe. Figures 3.1 and 3.2 show different types of plastic and copper fittings.

Pipe Sizes

All types of copper and plastic pipe are referred to by their diameter. Standard pipe sizes are ½, ¾, 1, 1¼, 1½, 2, 2½, 3, 4, 5, 6, and 8 inches. Pipe sizes are measured to the nearest fraction of an inch. The measurement most often approximates the inside diameter (ID) of small pipes of less than six inches and the outside diameter (OD) on large pipes. Most pipes, especially plastic pipes, will have the size and either ID or OD clearly marked. If in doubt, the end of a section of pipe can be measured.

Pipe Size and Flow Rate

After choosing a particular type of pipe, the next step is determining the proper pipe size for a given use. The size of pipe can be affected by many factors. The distance the water travels from the source to the end point, the pressure the water is under, the slope the water must

travel up or down, the resistance of the surface of the pipe, the number and sharpness of the bends in the pipe, the number of fittings, and expansion and contraction of the pipe due to temperature all affect the amount of water delivered in a given situation. Because of the complexity of these factors, overestimating pipe size and water delivery rates in order to avoid problems is common.

For complex construction projects where the pipes must be sized exactly to deliver the desired flow rate, two pieces of information are required, the desired flow rate in gallons per minute and the amount of resistance due to friction between the water and the surface of the pipe. The desired flow rate can be determined by adding the typical flow rates for different water outlets that will be operating at the same time. Once this number is obtained, a pipe size must be selected that will allow the desired flow rate while limiting losses in pressure due to friction to 5 pounds per square inch or less. Information on typical flow rates and friction losses for different sizes and types of pipe can be obtained from plumbing supply centers.

A less exact method is frequently used for less complex structures like homes and agricultural buildings. Pipe size tables like that shown in Table 3.1 on the following page can be obtained for different types of pipe. They are used to choose the correct pipe size given the pipe system length and the desired flow rate. When determining the pipe size needed, ten percent must be added to the measured length of the system to make up for losses due to fittings. For example, if the length of a system is 380 feet, the length to look at is 418 feet (380 + 38). For a system with this length and a flow rate of 5 gallons per minute, the correct pipe size is 1¼ inches.

Summary

Plastic and copper pipes are most commonly used in plumbing today. These materials are available in a variety of forms and sizes. The size of the pipes used in a plumbing system is determined by looking at the amount of water needed and the amount of friction between the water and the surface of the pipe.

Table 3.1 - PVC Pipe Size Table

Distance in Feet*	Lesson 3: Pipe Types and Size Requirements						
	Flow Rate (Gallons Per Minute)						
	2	3	5	7.5	10	15	20
Up to 25	½	½	¾	¾	1	1	1
50	¾	¾	¾	1	1	1¼	1¼
75	¾	¾	1	1	1	1¼	1½
100	¾	¾	1	1	1	1¼	1½
150	¾	¾	1	1	1¼	1½	1½
200	¾	1	1	1¼	1½	1½	2
300	¾	1	1	1¼	1½	2	2
400	1	1	1¼	1½	1½	2	2
500	1	1	1¼	1½	2	2	2
600	1	1	1¼	1½	2	2	2
700	1	1¼	1¼	1½	2	2	2½
800	1	1¼	1½	1½	2	2	2½
900	1	1¼	1½	2	2	2½	2½
1,000	1	1¼	1½	2	2	2½	2½
1,500	1¼	1¼	1½	2	2	2½	2½
2,000	1¼	1½	2	2	2½	2½	3
3,000	1¼	1½	2	2	2½	3	3

Credits

Annis, William H. *Basic Plumbing Skills*.
Athens, Ga: American Association for
Vocational Instructional Materials (AAVIM),
1989.

McConnell, Charles. *Plumbers and Pipe Fitters
Library*. Vol. 3, *Water
Supply · Drainage · Calculations*. New York:
Macmillan, 1989.

Phillips, Richard E. *Farm Buildings: From
Planning to Completion*. St. Louis:
Doane-Western, 1981.

Lesson 4: Measuring, Cutting, and Connecting Pipes

Lesson 4: Measuring, Cutting, and Connecting Pipes

Plumbing nearly always involves measuring, cutting, and joining of pipe and tubing. This lesson will describe how to perform these essential tasks properly.

Measuring Pipe

Most of the pipe used in plumbing is rigid, so accurate measurements are essential for the pipe system to connect properly to outlets and appliances. The first factor to consider in measuring pipe is the distance from the water source to the desired outlet along the exact path that the pipe will take. Another consideration is the length of the pipe being installed. The distance from the source to the outlet is divided by the length of the pipe. For a measurement of 50 feet, for example, five 10-foot lengths of pipe seem appropriate. However, the fittings used to join the sections of pipe also must be considered; they increase the length of the system. The amount of increase is dependent on the size of fittings and any angles made by the fittings. The length of the pipes may have to be adjusted to account for the fittings.

Cutting Pipe

Pipe may be cut easily with the proper tools. As discussed in Lesson 2, these tools consist of pipe cutters, which may be used with either plastic or copper pipe, and hacksaws for use on plastic pipes.

Pipes must be carefully measured before being cut. The pipe is measured with a tape measure or folding ruler. An allowance for the fittings must be made when determining the length of the pipe. The length to which the pipe will slide or screw into the fitting needs to be added to the length that will run between fittings. The point where the pipe should be cut is marked with a pencil; the marking should extend all the way around the pipe to make it easier to find. Because accurate measurements are necessary for correct installation of plumbing systems, measurements should be made to the nearest 1/32 of an inch regardless of the type of pipe used.

After the pipe has been measured, it can be cut.

To use the wheel-type cutters for copper pipe illustrated in Lesson 2, the cutter is opened by turning the handle until the pipe will fit between the wheel and roller. The pipe is placed in the base of the cutter and the handle is turned until the pipe touches the cutter wheel. The wheel is positioned on the point where the pipe is to be

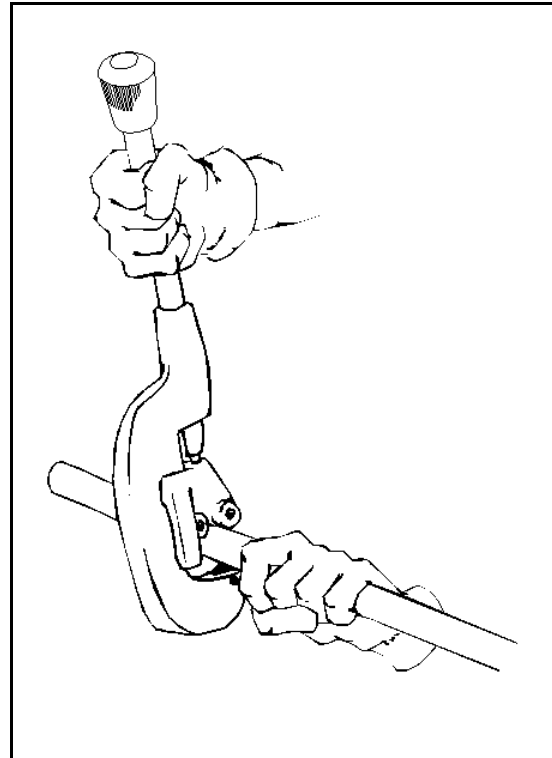

cut, and the handle is turned to press the wheel into the pipe. The tool is rotated around the pipe once, and then the handle is tightened and the tool is rotated again. This process is repeated until the pipe is cut. Figure 4.1 shows a wheel-type cutter in use.

A hacksaw is used to cut plastic pipe. If possible, the pipe is first placed in a vise to hold it still. The hacksaw blade is positioned on the mark for cutting. The hacksaw is pulled backwards, placing no pressure on the pipe, and then the blade is brought forward with pressure exerted to cut into the pipe. While sawing, the saw should be held at a 90-degree angle to the pipe, resulting in a square cut. Excessive force should not be exerted on the pipe while cutting. The process is repeated until the pipe is sawn through completely.

Plumbing

Any burrs, or sharp edges, and ridges left on the inside or outside of the pipe from cutting should be smoothed. With copper pipe, a small file, sandpaper, or a special reaming tool can be used; sandpaper or a knife is used for plastic pipe. Smoothing these cuts helps to insure a good watertight seal between the fitting and the pipe.

Joining Pipe

Several different methods are available for joining pipe. As discussed in Lesson 2, plastic pipes are joined using cements. Copper pipes can be soldered together; copper tubing may also be joined using flare joints.

Joining plastic pipe using cements is a relatively easy process. The end of the pipe and the fitting must be smooth and clean. A chemical cleaner is the best way to clean this material. Once the fitting and pipe end are clean, they are covered with an even coating of cement on the pipe and fitting socket. This cement usually acts quickly, so the pieces need to be joined together immediately and firmly to make sure they are seated correctly. The pipe should be given a quarter turn to make sure it is seated securely. A solid and permanent joint will be created after the pipe and fitting are held together ten seconds to a minute. A line of cement should appear all the way around the joint, indicating that enough cement was used. Joints created using cement are very durable and solid, and any mistakes will have to be cut out, since separating the joint is not possible without destroying the pipe and fitting. The directions and recommendations for cements should always be read before they are used.

Copper pipe is generally joined by soldering copper fittings to the pipe. This procedure is simple, but doing it well requires practice. First, the end of the pipe and the fitting must be clean; Sometimes soldering cannot be used to join copper tubing because of the heat of the propane torch and the location of the pipes or because the joint should not be permanent. In such cases, flaring is used to join the tubing. Making a flare joint involves using special tools to make the end of the tubing flare outward to join the fitting. After the tubing has been cut, a flare nut is placed on the tubing. The pipe is flared using some type of flaring tool. One common type of flaring tool is a yoke and screw

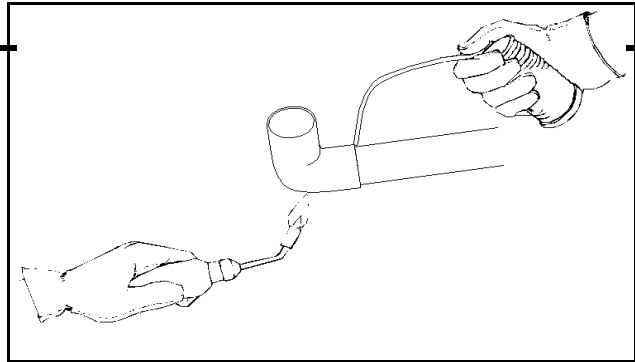

very fine sandpaper or emery cloth works well. The copper should be shiny and free of any oils or dirt. The use of soldering material, which looks like heavy wire, is enhanced by a compound called flux that removes impurities. Flux may need to be placed on the pipe before soldering, although some types of solder contain a core of flux or acid that makes additional flux unnecessary. Since different kinds of solder have different compositions and recommended uses, the manufacturer's instructions should be read before the material is used. To solder, the fitting is placed on the pipe or tubing, and a propane torch is used to heat first the pipe and then the fitting around the entire joint until the solder melts when touching the joint. The solder is held to the rim of the fitting, as shown in Figure 4.2, and is drawn into the joint. The solder is applied around the joint until it is found around the entire rim of the fitting. The excess solder is wiped away while the pipe and fitting are still hot.

As the solder cools in the joint, it bonds the pipe and fitting like a metal weld, providing an excellent seal.

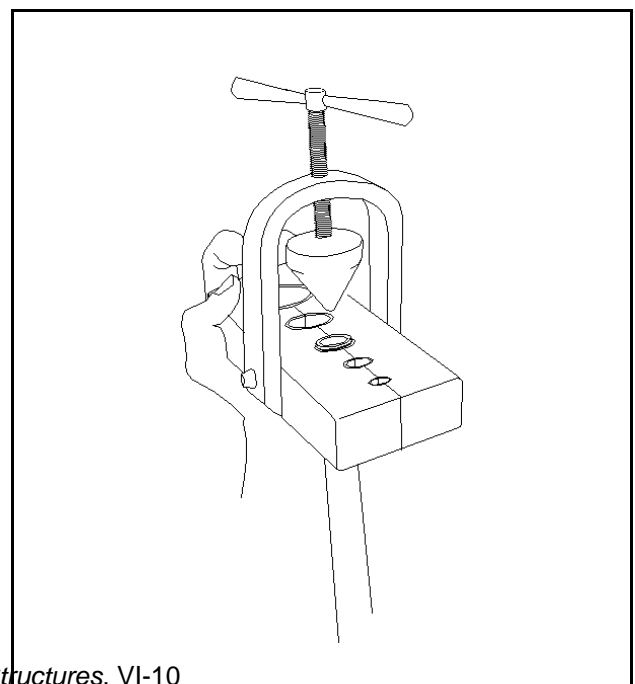

Lesson 4: Measuring, Cutting, and Connecting Pipes

flaring tool (see Figure 4.3), used with different sizes of pipe. The tubing is placed in the correctly sized opening of a flaring block and secured in position with the end of the tubing extending above the block about $\frac{1}{2}$ the depth of the block chamfer. The yoke of the flaring tool is placed over the block, with the compression cone centered over the tubing. The screw is tightened to form the flare between the block and the cone; the screw should not be turned too far, since the tubing may split. When the flare is finished, the fit of the flare is checked to the seat of the flare nut. The fitting is then placed against the flare, and the nut is tightened to hold it in place.

Summary

Precise measurements of the distance between a water source and outlets, pipe, and fittings are necessary to determine the lengths of the pipes needed for a plumbing system. The next step is cutting the pipe to the appropriate length using the proper tools. When pipe has been cut,

smoothed, and cleaned, the pipes and fittings are joined using one of several methods, depending on the type of pipe. When properly installed, fittings should be durable and watertight.

Credits

Annis, William H. *Basic Plumbing Skills*. Athens, Ga.: American Association for Vocational Instructional Materials (AAVIM), 1989.

Brunk, Art. *Building Maintenance*. Module III, *Plumbing*. University of Missouri-Columbia: Instructional Materials Laboratory, 1990.

McConnell, Charles. *Plumbers and Pipe Fitters Library*. Vol. 3, *Water Supply · Drainage · Calculations*. New York: Macmillan, 1989.

Plumbing

Lesson 5: Protecting Water Pipes from Freezing

Lesson 5: Protecting Water Pipes from Freezing

A well-designed and constructed plumbing system will seldom freeze. Freezing is preventable if certain factors are considered when planning pipe installation, and methods of insulating and heating pipes are available to prevent freezing. If lines do freeze, thawing the pipes without causing damage is possible if it is done correctly.

Factors to Consider When Installing Pipe

Running water lines underground below the frost line is a proven method of preventing freezing in the lines. How deeply the pipes are laid depends on the frost line in the area. The average frost line in Missouri is 36 inches. Pipes should be below the frost line. Most people install their pipes a foot below the frost line to help prevent freezing. A county Extension office or reference materials from a local library can provide information on the exact depth necessary in an area.

When installing plumbing in and around a structure, the design of the plumbing system should take into account the potential for freezing. Designing the system so that pipes are placed in interior rather than outside walls. When conditions heavily favor freezing, other measures may protect interior pipes. Supplying at least minimal heat to the inside of the structure using any appropriate heating system will greatly reduce the risk of pipes freezing

can protect them from freezing. If pipes must be exposed to cold temperatures, certain measures can be taken to avoid freezing. Insulation should be used around pipes placed near exterior walls. Insulation with an R factor of 6.5 to 8 offers substantial protection. The insulation should be carefully wrapped, with the ends butted together tightly and joined with tape.

Frost-free faucets should be used outdoors; their design prevents water from remaining in the section of pipe extending above the ground when the faucet is not in use. If pipe is installed in an area subject to freezing, a drain valve should be added. The valve allows water to drain out of the pipe, preventing damage due to freezing.

Methods to Prevent Freezing

Where water lines come to the surface, a significant threat of freezing exists, and protective measures should be taken. In cold weather, any exposed pipe should be wrapped in waterproof insulation; with extremely cold temperatures, even frost-free faucets should be insulated. Protecting the pipe from direct winds will also reduce the threat of freezing. One way to protect the pipe would be to create a temporary shelter around the exposed pipe using stacked hay bales.

inside the building. Another method of preventing freezing involves using electric heat tape. The heat tape is placed along the pipe, which is then wrapped in insulation to hold the heat close to the pipe, as shown in Figure 5.1.

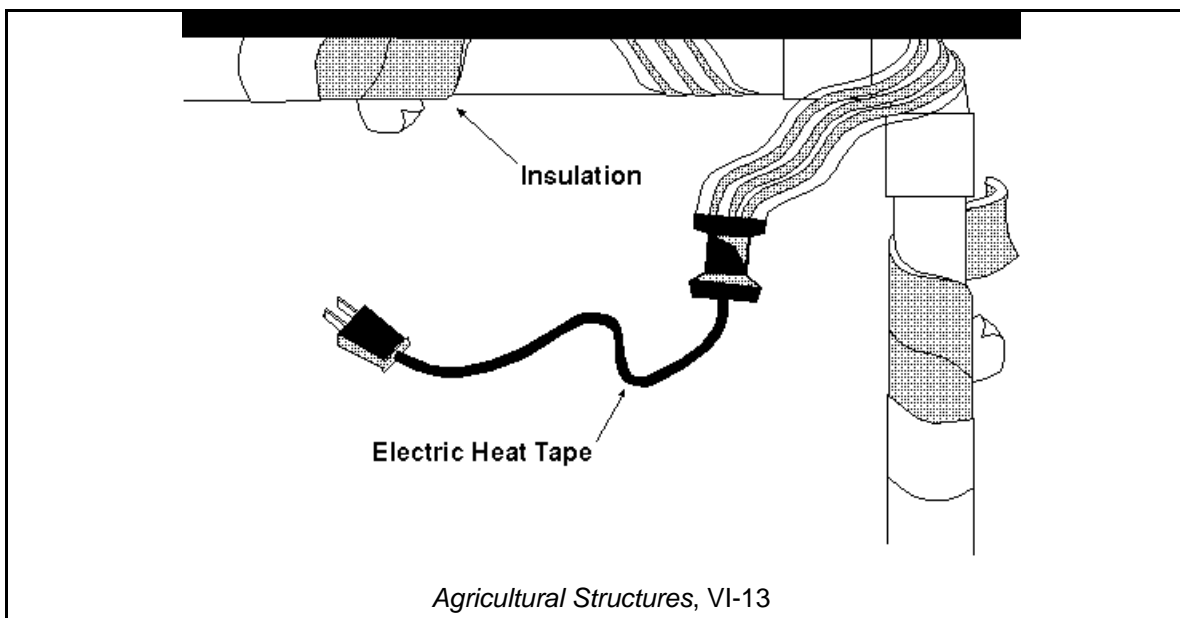

Plumbing

The tape carries an electrical current through it to supply heat, much like an electric blanket. Heat tape can be wired either with a timer set to turn it on and off at certain times or with a thermostat that activates the tape at a designated temperature.

Figure 5.1 - Electric Heat Tape

Allowing the water to run continuously can also prevent freezing. Monitoring a water line's output is useful if freezing is likely. As ice forms in the pipe, the water pressure begins to drop. The line should be opened a little so that the water runs continuously. Running water is much more resistant to freezing; the water may also help remove ice that has already formed in the line. If the pressure returns to normal, the water should be allowed to drip or trickle from the faucet until the temperature rises to a safe point.

Thawing Frozen Water Pipes

Should pipes become completely frozen and obstructed, a careful inspection of all exposed water lines will be necessary. If any breaks are found, the water to that section of the line or to the entire system should be turned off. The break will have to be repaired, usually by cutting out the broken section and putting in a new pipe with fittings, before turning the water on again.

To thaw frozen pipes, the frozen section of the pipe needs to be heated. Professional plumbers frequently use torches for this task. However, this practice can be dangerous. If the flame comes in contact with combustible material, a fire can result. With the pipes frozen, water may not be available to douse even a small fire. Also, heating the pipes in one spot too quickly can cause the water to boil, creating enough pressure to cause the pipes to explode. If the pipe is too hot to touch, too much heat is being applied. A flame should never be applied directly to a plastic pipe, since it will melt.

Safer methods can be utilized to heat pipes. Electric heaters, hair dryers, heating pads, and electric blankets are often effective, although these devices should only be used after evaluating if any danger of electrical shock exists when using them around water lines. Placing embers or charcoal briquettes in an appropriate container near the frozen pipes may be useful for thawing exterior pipes.

Summary

With frozen water pipes, prevention is by far the best solution. Pipe lines should be buried below the frost line. The design of the plumbing system should also prevent freezing, by avoiding placing pipes near exterior walls or using insulation where appropriate, using frost-free outdoor faucets, and installing drain valves. If pipes are likely to freeze, they should be insulated or heated if possible, or the water may be allowed to run continuously. Frozen lines must be inspected for leaks before applying heat to the frozen section. Thawing must be done safely, without starting a fire, causing pipes to explode, or creating a situation where electrical shock is possible.

Credits

Annis, William H. *Basic Plumbing Skills*. Athens, Ga.: American Association for Vocational Instructional Materials (AAVIM), 1989.

McConnell, Charles. *Plumbers and Pipe Fitters Library*. Vol. 3, *Water Supply · Drainage · Calculations*. New York: Macmillan, 1989.

Mississippi State University Extension Service. *Frozen Pipes: Causes and Cures*. <http://www.ext.msstate.edu/pubs/is1438.htm> (25 Sept. 1998).

Lesson 1: Fencing Basics

Fences are used extensively in agriculture. Most fences are designed to contain or restrict the entrance of animals, but they may also be built for appearances. This lesson will introduce some fencing basics, such as legalities, safety, and construction and repair.

A Legal Fence

Because fencing obligations, responsibilities, and boundaries have been and continue to be a source of conflict, laws have been enacted to help define responsibilities and liabilities concerning fences. Although local counties and townships had their own regulations, the state of Missouri was legally an open range until 1969. Property owners had the responsibility of fencing animals out of their property to avoid damage. However, in 1969, Missouri changed the law to a closed range system. This law requires livestock owners to confine their animals and makes them liable for damages caused by unrestricted animals. This law covers horses, cattle, swine, and similar stock.

The changing laws brought about the need for defining what a fence is and the minimum acceptable standards for a fence. Questions, such as who is responsible for the construction, maintenance, or replacement of a shared fence, can be complicated. If disputes cannot be settled by the owners, the local courts may have to determine what should be done. A lawful fence may be defined in one of two ways, depending on the local regulations. Most counties have laws based on either the state's general law or the optional Fence and Enclosure Act of 1963. Adoption of the Fence and Enclosure Act suspends the provisions of the general statute.

Under the general law, a fence is a sufficient enclosure if it meets the following standards.

- Hedges are at least 4 feet high.
- Fences composed of posts and rails, post and palings, posts and wire, posts and boards, or palisades are at least 4½ feet high with posts firmly in the ground not more than 8 feet apart.
- Fences consisting of woven wire, wire netting, or wire mesh are at least 4½ feet

high with posts not more than 16 feet apart.

Other fence structures satisfying the definition of a lawful fence are described as well, including worm (rail) fences, turf fences, and stone or brick fences. The law states that all fences should be constructed to resist horses, cattle, swine, and similar stock.

If a county has adopted the optional provisions of the Fence and Enclosure Act of 1963, a lawful fence is defined as follows:

- A fence not fewer than four boards per 4 feet of height, each board to be spaced no farther apart than twice their width and to be fastened to posts not more than 12 feet apart with one stay. A stay is a vertical member attached to each board or wire forming the horizontal members of the fence.
- A fence of four barbed wires supported by posts not more than 15 feet apart with one stay or 12 feet apart with no stays.
- Any fence that is at least equivalent to the types of fences in the other categories.

Common Fencing Tools and Safety Measures

Fences come in a variety of forms and materials. Board, rail, panel, woven wire, barbed wire, and smooth wire fences are all common on farms. Most fences can be erected with using a few basic tools: a hand-operated or power-driven post hole digger or auger, a metal rod for packing earth around posts, a metal post driver or a post maul for driving wooden posts, a hand ax or chain saw, fence stretchers, a hammer, a tape measure, fencing pliers, a roll of nylon string to help lay out straight lines, and a level to help assure that posts are set straight. Using these tools safely is important, since fencing can be dangerous work.

Protective clothing, such as steel-toed boots, heavy pants, gloves, and eye protection, is very beneficial when using any of these tools. Gloves are especially useful and should be worn to prevent blisters and other injuries to the hands.

Building fences is usually hot and hard work; heavy clothing and boots are not always

Fencing

comfortable under these conditions. However, this clothing can help avoid an injury.

A hand-operated post hole digger consists of two blades, each with a separate handle, that are joined by a hinge. Soil is removed by digging the blades into the earth and then pulling the handles outward and lifting the digger upward. When using this tool, the target area for digging should be clear and free of large rocks that can produce flying chips. Maintaining good posture while operating this tool will help reduce back strain or injury.

Power-driven post hole diggers, which have an auger that bores a hole into the ground, come in a variety of styles, such as one- or two-man gas-powered units or tractor-powered units attached to the front or back of a tractor. To operate these safely, the manufacturer's recommendations should be followed. Keeping any loose clothing away from the auger can prevent serious injury. Augers are powerful and can easily mangle a person's arms or legs if clothing gets caught in the auger as it twists. Hearing and eye protection should be used.

The metal rods used for packing earth around posts are close to 6 feet in length. They may weigh 20 to 40 or more pounds. One end is pointed to chip at or break hard material in a post hole, while the other end is flat for packing earth and rocks. Protective glasses can prevent injury to the eyes from rock chips. Gloves and steel-toed boots can help avoid injury to the hands and feet from the heavy rods.

Metal post drivers are weighted metal tubes with a sealed top and handles on the sides. The open end of the post driver slides over the top of the post and is raised up and slammed down on the post to drive it to the correct depth. Good posture and control while lifting the post driver can help avoid back injury. Gloves will help prevent blisters.

A post maul is a large sledgehammer-type tool for driving sharpened wooden posts. They often weigh 10 or more pounds. Anyone using this tool should make sure that everyone working in the same area is out of striking distance. Gloves should be worn to protect the hands, while eye protection should be worn to prevent injuries from stray flying material.

A hand ax is sometimes needed to clear an area of limbs or brush before building a fence. Safety glasses, gloves, and steel-toed boots are needed for safety.

A chain saw is used to clear areas for fence construction or to cut wooden posts or rails to the desired length. Hearing protection, eye protection, gloves, and steel-toed boots will increase safety when using this tool.

Fence stretchers are a tool that pulls wire taut before it is fastened to the fence posts. While the tool itself may not be dangerous, it should be used with caution, because wire that has been stretched too tightly may break and cause injuries, as discussed in the next section.

Safety Measures for Fence Construction

Certain precautions can be taken to help reduce injuries when building fences. To safely construct a fence, the clothing and safety accessories mentioned above should be used; a hat and a shirt with long sleeves may provide additional protection. If possible, fence construction should not involve working alone in an isolated area, since help may be necessary if an injury occurs. The tools used for construction of the fence should only be used as designed and recommended by the manufacturer. Fence construction may involve heavy lifting, so proper lifting techniques, such as keeping the back straight and using the leg muscles to help move the weight, should be used. Heavy loads should also be held close to the body to help reduce strain. Unexpected hazards such as wasps, bees, snakes, and plants such as poison ivy are also to be considered and avoided if possible. Caution should be used when working with wire, which commonly causes cuts. Barbed wire is particularly hazardous.

Because wire must be stretched before fastening it to the posts to make it rigid, overstretching may occur, causing the wire to break and whip back against or around the person stretching it or someone else. Wearing gloves and eye protection is a must.

Lesson 1: Fencing Basics

Summary

Fencing is hard but necessary work. A good fence is required for livestock, both to keep the animals safe and to prevent them from damaging other people's property. Any fence built should meet the definition of a legal fence for its owner to avoid liability for damages. When building a fence, caution is necessary for safety. Using basic fencing tools safely, wearing protective clothing, and taking precautions can help make fencing safer.

Credits

Jordan, Cora. *Neighbor Law: Fences, Trees, Boundaries, and Noise*. Berkeley, Calif.: Nolo Press, 1991.

Missouri Fencing and Boundary Laws (G00810). University Extension agricultural publications, 1993.

Ramsey, Dan. *The Complete Book of Fences*. Blue Ridge Summit, Pa.: TAB Books, Inc., 1983.

Fencing

Lesson 2: Setting and Bracing Posts

Lesson 2: Setting and Bracing Posts

As indicated by the descriptions of a legal fence in the last lesson, strong, properly spaced posts are an important part of a fence. This lesson describes corner posts, line posts, and braces and explains how to install them.

Materials and Tools for Wood Posts and Braces

The basic materials needed when installing wood posts and braces are the posts and braces themselves, large nails, such as 16d tempered ring shank pole barn nails, wire for wire braces, and staples. Wood corner posts are often chemically treated to resist rotting and may last for 10 to 30 years. They are generally 6 or more inches in diameter and about 8 feet or more in length, since they will need to be set 3 to 3½ feet into the ground. Wood line posts are 2½ inches to 6 inches in diameter, with a diameter of 5 inches preferred for most fencing jobs, and 5½ to 8 feet in length. Most of these posts are chemically treated. Braces are the crossed or diagonal pieces of material running between the post being braced and the next post in line or a wood, metal, or concrete anchor. The most common brace material is a wood brace pole approximately 5 inches in diameter; they are commonly 8 feet in length, but longer braces of 10 or 12 feet add more structural support to the brace structure. Large nails attach the brace pole to the posts. The best type of wire to use for wire braces is 12½ gauge high tensile smooth wire. Staples are used to attach the wire to the posts.

Site preparation tools are necessary to install wood posts. The site preparation tools needed depend on the site, since all brush, old fencing, trees, and large rocks are removed. In some cases, filling low areas and excavating elevated ones is beneficial. An ax may be needed in many cases. A wheelbarrow and chain saw can be useful also. Sites requiring more preparation may call for heavy equipment, such as a tractor with a brush-hog type mower and a grading blade or a bulldozer.

Once the site is prepared, layout and construction tools are necessary. Tools needed to build the fence include a post hole digger, shovel, and hoe. Some of the tools used in site

preparation, such as a wheelbarrow and chain saw, may be used again. Layout tools include a tape measure 100 feet or more in length and a level.

Locating Wood and Steel Anchor-and-Brace Assemblies

Much of a fence's strength depends on the quality of the anchor-and-brace system, whether the posts are steel or wood. If the braces fail, the fence will too. Also, the appearance of the fence is important; corners and brace assemblies are the focal points and should be constructed neatly.

Fence corners generally require anchor-and-brace assemblies, sometimes referred to as fence structures. Brace assemblies may also be placed at points along the fence line to compensate for the effect of stresses exerted on the fence. The location of these structures will depend on the type of fence (barbed wire, woven wire, high tensile smooth wire, etc.), topography of the ground, type of ground (dry, rocky, swampy), length of the fence run, and bends in the fence line.

Installing Anchor-and-Brace Assemblies and Brace Wires

Figure 2.1 on the following page shows some different configurations used for corners or braced-line post systems. The most common type of fence structure is the H-brace, which consists of two posts set in the ground with a brace pole between them. A variation of this type of assembly is the double H-brace, which adds an additional post and pole to the structure.

The double H-brace is used for longer stretches of fencing and stretches where higher tension or stress loads will be placed on the structure. A third variety is the angle brace, which utilizes a single post, a brace pole, and a flat rock or formed concrete pad. The brace pole is placed at an angle to the post, with one end set into the post and the other fitted to the top of the rock or pad. This type of structure is commonly used when slight bends or turns are required in the fence line. Another assembly has an anchor called a deadman near the corner post. The anchor is driven in the ground or placed in concrete. A brace wire attaches the deadman to the post, adding rigidity to the assembly.

Fencing

The first step in installing the common H-brace

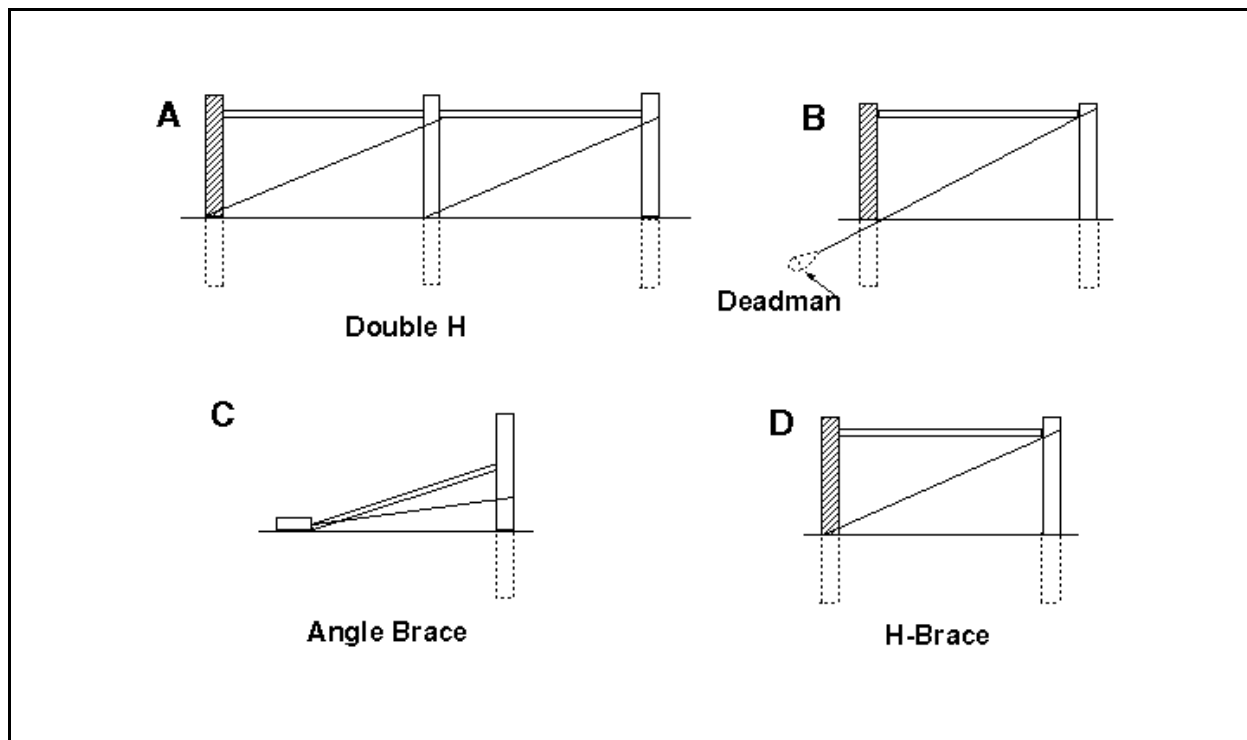

assembly is setting the posts in place. The end or corner post is placed first. Placing the post will involve digging a hole to an appropriate depth, setting the post in the hole, and filling in the hole around the post with dirt or gravel. The second brace post can then be put in place in line with the first at the desired distance. Because of the angles formed by an H-brace, a longer brace pole will provide more structural strength to the fence. The industry standard is 8 feet in length, but when a single H-brace is needed due to ground conditions or other factors, using a 10- to 12-foot brace is preferable.

Once the posts are properly set and tamped in place, a chain saw is used to form a notch for the brace pole in each post. The notches should be perpendicular to the fence line, so the flat surface at the base of the notch is at a 90-degree angle to the fence wires. Typically, a good height for the bottom edge of the brace pole is 36 to 42 inches from the ground, but the height should be determined by the spacing of the fence wires, so the brace does not interfere with wire placement. For structural soundness, the brace pole should be placed as high as feasible on the structure.

The next step is to install the twist wire. The wire is wrapped twice completely around each of the posts that the twist wire will connect. The direction of the fence pull will determine the placement of the wire. The direction of the pull depends on which section of fence coming into the brace is longer and will exert more stress on the brace post. The twist wire is loosely stapled low on the brace post farthest from the longer stretch of fence and just above the brace on the post next to the length of fence being braced. As much slack as possible is removed from the twist wire by pulling on both ends, and the wires are spliced together.

After some tension is put on the structure, the ends of the brace pole are nailed to the posts using the 16d nails ring shank nails. Four nails are used at each end, one on top, one on each side, and one on the bottom.

Next, a twist stick is inserted between the wires. The stick may be a 1-inch wood dowel, fiberglass rod, or a short section of 2" x 4" or 2" x 2". The twist stick should be a minimum of 20 inches in length. Rotating the twist stick will put tension on the wires.

Lesson 2: Setting and Bracing Posts

The wires are twisted so that when the assembly is finished the stick will be pulled against the brace pole on the opposite side from where the wire is attached. As tension is placed on the twist wire, the structure should begin to move in the opposite direction from the pull of the fence. A good rule of thumb is to move the end post approximately $\frac{1}{2}$ to $\frac{3}{4}$ of an inch out of plumb away from the direction of pull. Less tension may be necessary if a gate will be attached to the end post, thus providing more balance

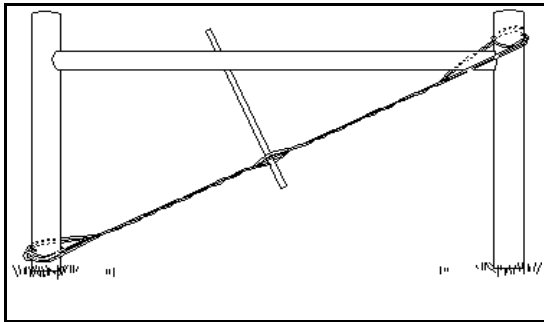

against the pull of the fence, or on short fence runs where the fence wire has less tension.

Once the structure is tensioned into place, the twist stick is attached to the brace pole. The preferred method is to drill a $\frac{1}{4}$ -inch hole through the twist stick in line with the brace and then drive a 16d galvanized nail through the stick and into the pole. This method is preferable because the nail can easily be removed to tension the wire again. A completed H-brace is shown in Figure 2.2.

Installing Wood Line Posts

Wood posts are common for corners and braces, but they are becoming less popular for line fencing. They require more maintenance and have a shorter life span than steel, which has made their use selective.

Before the posts can be installed, the fence line must be laid out. Laying out the fence line can be done by having one person stand behind a corner post and another person move down the fence line toward the next corner post. The person moving down the fence line holds a movable post, or sighting pole. The person at the corner post directs him or her to a position that lines up the corner post, the post being held, and the next reference point, which may be either the corner post or, for hilly ground, the farthest point that can be viewed clearly. The

spot is marked for reference in aligning the posts.

The installation of wooden line posts is a relatively simple process. The first step is to measure off the line post spacing. The placement of wooden line posts is determined by the type of fence, the amount of pressure that will be placed on the fence by livestock, dips and rises in the ground, and whether steel, fiberglass, or other types of posts are also placed in the fence line. For field fencing, line posts are commonly 14 to 20 feet apart, while 8 to 16 feet is typical for more confined lots. A tape measure may be used to measure out the exact spot for each post, or the distance between them may simply be estimated by pacing out the distance. An individual may lay out a 100-foot measuring tape and walk the length of it, counting the number of steps taken. Dividing 100 by the number of steps can give a relatively accurate length pace, which may be used for post layout.

Then the ground line is marked on the posts; line posts are usually set at least 30 inches into the ground. The holes are dug to the proper depth, and the posts are set in packed dirt. A level may be used to check the posts' plumbness. An alternative method of placing wood posts is sharpening and driving them into the ground with a post maul or a hydraulic post driver mounted on a tractor. Posts that are driven into the ground are stronger than those that are hand set.

Special considerations for setting any line posts are topography and ground conditions. Wet areas will typically require a longer post driven deeper into the ground to provide stability for the fence. Posts set in low areas may need special bracing to keep them from lifting out of the ground. One method is to nail a pressure-treated 2" \times 6" about 24 inches long horizontally to the bottom of the post. Another method is to drive a steel t-post 4 to 5 feet long as deep as possible at an angle next to the post and attach a wire or chain to the t-post and wooden post.

Tools Needed for Braces and Steel Posts

As wood posts become less common, steel posts are growing in popularity. Steel posts have several advantages over wood; they are

Fencing

fireproof, economical, and easy to install and maintain.

Steel posts are commonly available in lengths of 5 to 8 feet. The same type of post may be used. Some of the same tools used with wood posts are needed with steel posts. Tools for clearing a fence line, such as a chain saw, ax, or heavy equipment, may be used as described previously.

Some additional tools are required to work with steel posts. A metal post driver is an indispensable tool for setting posts. Some metal fence systems use bolts and nuts to attach braces. A set of wrenches or a socket set will meet these needs. Other metal brace systems

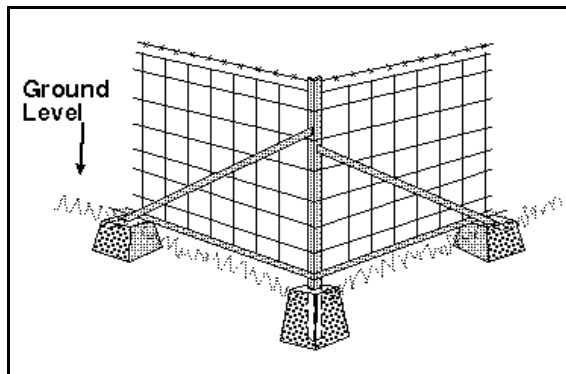

are welded in place, thus requiring a portable arc welder. Metal posts vary in configuration and sometimes require specific fasteners that are supplied with the posts. Most fasteners are easily attached with fencing pliers. If a special tool is needed for the fasteners, it should be available from the retailer. Metal corner posts and braces are often set in concrete, as shown in Figure 2.3. Tools needed for working with concrete include either a portable cement mixer or a wheelbarrow, a shovel, and buckets or a hose to supply water.

Installing Steel Post-and-Brace Assemblies

The first step in installing steel post-and-brace assemblies is to dig the anchor post hole. The hole for the anchor posts should be 3 feet deep. The post hole will provide more stability if it is approximately 20 inches in diameter at the bottom and 18 inches in diameter at the top. The ground line is then marked on the post.

for both corner and line posts in a light duty fence. However, often the corner post is a metal pipe 5 or 6 inches in diameter that has been filled with concrete.

The next step is to bolt or weld the braces to the anchor post. Braces are generally set at angles of approximately 45 degrees. Holes are then dug where the braces touch the ground. The hole must extend 6 inches below the frost line. The depth varies depending on the geographical region, but the hole should be a minimum of 18 inches deep and is preferably deeper, usually 2 to 3 feet.

When the holes are ready, the concrete is placed around the post and braces. The top of the concrete should be molded to slope away from them to direct water away from the post and prevent problems caused by freezing. Finally, a level is used to make sure the post is plumb.

The anchor-and-brace system for corner and line posts is basically the same. The only difference is that with line posts the braces are attached to extend directly along the fence line rather than form a 90-degree angle.

Installing Steel Line Posts

Installing steel line posts is simpler than working with wood line posts. The first step is measuring the line post spacing and aligning the posts. The ground line is marked on the posts, which are set 2 to 3 feet deep. They are then driven to the proper depth using a steel post driver.

Factors Affecting Gate Installation

Fences would be of little use without a gate to allow entrance and exit. The size and weight of the gate will greatly affect the fence and brace structure construction. A heavy gate will provide a counter force to the pull of the fence, so the weight of the gate should be taken into account when tensioning the brace structure. Also, gates should not be hung from lone posts, which are single posts without bracing, because they will not give enough support. A larger post, 7 inches in diameter or more, should be used for the gate post. Gates should be hung in line with the fence structure, providing maximum support for the gate. If double gates are hung,

Lesson 2: *Setting and Bracing Posts*

a brace assembly must be installed on both sides of the opening.

Summary

The first step in building a fence is installing the posts. Both wooden and steel posts are commonly used for fences. Two types of posts make up fences: anchor-and-brace posts and line posts. Anchor-and-brace assemblies are

necessary at fence corners; the placement of other fence structures along the fence line will depend on the type of fence, topography of the ground, type of ground, length of the fence run, and bends in the fence line. Because the size and weight of gates will affect the fence, these factors must be taken into account when installing a gate.

Credits

Ramsey, Dan. *The Complete Book of Fences*. Blue Ridge Summit, Pa.: TAB Books, Inc., 1983.

University Extension agricultural publications, University of Missouri-Columbia.

- G1191: Selecting Wire Fencing Materials
- G1192: Constructing Wire Fences

Lesson 3: Barbed and Woven Wire Fences

Lesson 3: Barbed and Woven Wire Fences

Barbed and woven wire fences are common in agriculture. This lesson describes the basics of building these two types of fences, including the materials and tools needed and the process of installing the wire.

Materials and Tools for Barbed Wire Fences

The materials needed to erect a barbed wire fence are barbed wire and staples or metal clips for attaching the wire. Barbed wire is fencing material made of wire strands twisted together with wire barbs placed at various intervals. The main characteristics to look for when purchasing barbed wire are gauge, number of barbs, wire coating, and type of wire. Barbed wire is manufactured and sold by gauge, a number representing the diameter of the wire. A lower number corresponds to a larger diameter. The most common gauges in Missouri are 12½ and 14 gauge. The configuration of the barbs on the wire will vary slightly by manufacturer, but two and four points are the most common. Barbed wire will usually be coated with zinc or aluminum to help it resist rust. Both coatings are effective, but aluminum will last longer under most circumstances. Barbed wire comes in either soft wire or high tensile wire. The wire is fastened to posts using either staples for wood posts or specially designed metal clips for metal t-posts.

Usually fences will use only wood or metal posts, but if the land is relatively flat and free from rocks, they may have alternating metal and wood posts.

Metal posts will last longer than wood posts because they will not rot, but they are not as strong as wood posts. By alternating posts, costs are reduced with a minimal reduction in the strength of the fence.

Barbed wire is selected by evaluating the cost and needs of the operation. Heavier gauges are more expensive, and wire with 4-point barbs is usually more costly than wire with 2 points. Post spacing, the number of strands used, the size of the area to be fenced, and the type of livestock to be contained are all factors to consider when choosing wire. For example, a small lot for cattle would benefit from five strands

of 12-gauge wire with 4-point barbs. A sturdy fence would be necessary in an area where cattle would be pushing against the fence often. This type of fence may also require closer post spacings, and the use of more wooden posts rather than metal t-posts. A fence for cattle on a range area works well with four strands of 2-point 14-gauge wire. Posts may be spaced more widely for this type of fence, and metal t-posts would work well for this situation.

Relatively few tools are necessary to build the fence. A claw hammer, fencing pliers, and fence stretcher are sufficient.

Laying Out Barbed Wire

Barbed wire fence installation is not complicated, but it can be dangerous because of the sharp barbs. When working with barbed wire, observing all safety practices is a must.

Once the posts are in place, the bottom strand of the wire is wrapped around the corner post two or three times and stapled securely. The end of the wire should be twisted tightly around the wire strand. This connection to the post must be very secure for the wire to be stretched without coming loose. The number of strands of wire used determines the height of the bottom strand.

Figure 3.1 shows an example of some typical spacings.

Having attached the first strand at the desired height, the wire may be unrolled along the fence line on the stock side of the posts. The length of wire unrolled depends on the topography, fence layout, and the position of fence brace structures. Barbed wire comes in rolls of wire a quarter mile long, and the entire length of the wire can be laid out at once under the proper conditions. Using short stretches of wire is more costly, because more time and more materials, most notably for brace assemblies, are required. More braces are necessary because the fence should be braced at each end of a stretch of wire. The same procedure is used for each strand, from the bottom to the top.

The wire should be placed as close as possible to the fence line. Walking the fence line and moving the wire into place may be necessary. This practice helps to remove excess slack prior to stretching the wire.

Stretching Barbed Wire

Fencing

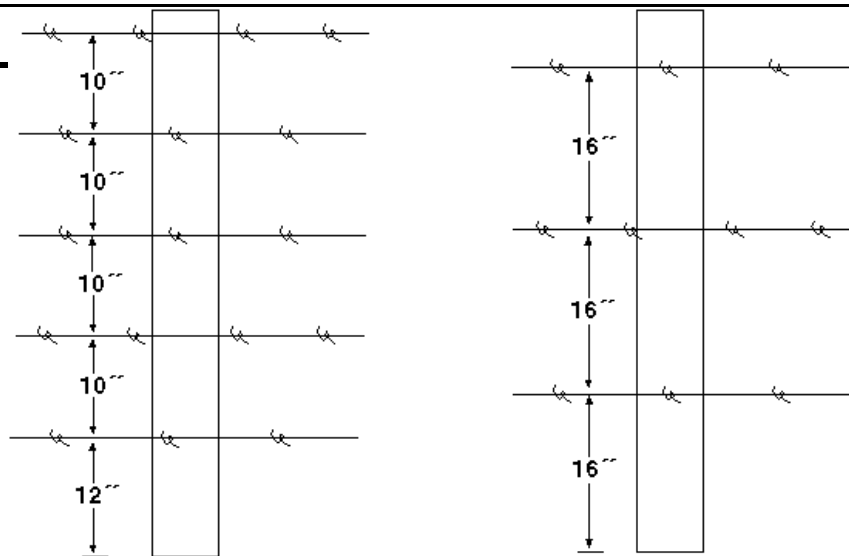

The next step in putting up the fence is stretching the wire. Most fence stretchers are simple and effective. Many designs are available, including systems that operate on winches, pulleys, or ratchet systems. One common tool has a clamp on one end to grasp the wire while the handle operates as a lever against a post to stretch the wire. Tractor-operated or hydraulic stretchers are available for larger fence construction projects.

To operate a stretcher, it must be attached to the wire being stretched. The stretcher can be attached to a solid object in line with the wire, usually the post of a brace structure, or a piece of equipment. Short stretches should not be made to line posts because these posts are not secure and will pull over easily. For longer stretches, the wire can be stretched and spliced in the middle to distribute the pull more evenly throughout the wire. The stretcher then connects to the wire only. Slack is taken up with the stretcher, and then the wire is spliced once it is at the proper tension.

The length of wire to be stretched at a time depends on the topography of the area and the stretching tools. Hilly areas require stretching short sections at a time to keep the wire level. A rule of thumb is to stretch from 5 to 20 rods at a time; a rod is 16½ feet. Stretching longer sections of wire will take less time.

Using the stretcher to take up the slack, the wire is slowly stretched to the point of being relatively tight and straight. The wire should not be too tight to allow expansion and contraction of the metal wire due to temperature changes. Wire should never be stretched too tightly, because overstretching may break the wire. Depending on the length of the stretch, it may be necessary to walk along the fence line and untangle the wire.

Attaching Barbed Wire

Once the fence is tight, the wire is attached to the post while the stretchers are still in place. The end of the wire should be long enough to wrap completely around the post twice and then be tied off back onto the wire itself. The wire generally is then stapled to the post to prevent slippage if the tie works loose.

Attaching Barbed Wire

Staples are used to attach wire to wood posts. Although most fencing pliers have a hammering surface, a hammer is useful if much stapling is required. When attaching the wire, the staples are angled as shown in Figure 3.2, with the staples set diagonally at a slight downward angle to resist the pull of the wire. The staple is then driven into the post. Staples should not be driven in so tightly that they and the wire become embedded in the post. The wire needs room as

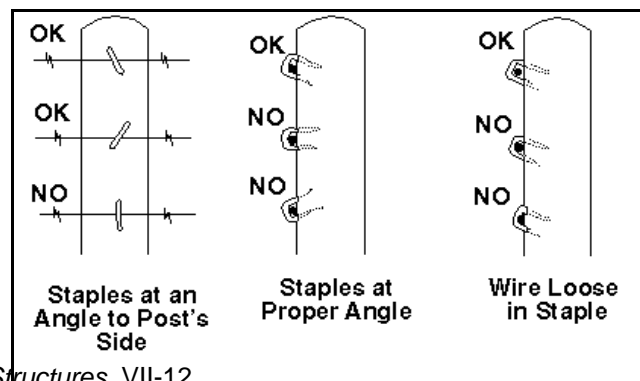

Lesson 3: *Barbed and Woven Wire Fences*

it expands and contracts with changes in temperature.

If steel posts are used, the wire is attached using metal clips supplied with the posts. These clips are used to hold the wire against the post. Fencing pliers are most commonly used to position the clips, but some types of posts require a specific tool supplied by the post retailer to attach them.

Woven Wire Materials and Tools

To erect a woven wire fence, the appropriate type of wire and fasteners are necessary. Woven wire is a type of fencing material in which wires are connected together to form a mesh. The horizontal wires are continuous throughout the fence. The vertical wires, or stays, are attached in one of two ways. One method has short pieces of wire wrapped into a knot at each horizontal wire, so the stay is not one piece of wire. This variety is referred to as hinge lock wire because the knot resembles a hinge. Another method has a continuous stay with short sections of wire forming the knots that attach the stay to the horizontal wire. This type of woven wire is referred to as stiff stay wire.

Woven wire comes in either soft or high tensile wire. The traditional soft wire fencing typically has wire of a heavier gauge for the top and bottom wires, while high tensile wire uses wires that are all the same gauge.

An industry standard system of labeling indicates the size of the woven wire fencing. A three-number designation identifies the number of horizontal wires, the height of the fence, and the distance between vertical stay wires. For example, a designation of 10-47-6 would identify wire that has 10 horizontal wires, is 47 inches tall, and has stays spaced 6 inches apart.

When selecting woven wire, the chief factors to consider are the gauge, protective coatings, and the application, which may affect the pattern, weave size, or height of the wire chosen. Like barbed wire, woven wire is sold by gauge. The lower the number assigned, the larger the diameter of the wire is. Zinc, aluminum, and sometimes vinyl coatings extend the life span of the wire. The wire is rolled out either to the brace structure that it is to be attached to or to the point where it will be spliced onto another roll. Rolls of woven

woven wire. Many patterns and weave sizes are available, and the fencing comes in a variety of heights, commonly 20 to 60 inches. When selecting woven wire, the application is critical. For example, chickens would need a higher, lighter weight fence with smaller openings than fencing for hogs.

Woven wire may be used with either wood or metal posts. Wood posts require staples for fastening the wire, while metal posts call for wire clips.

The tools needed to put up the fence are much the same as for barbed wire. They include a claw hammer, fencing pliers, and a woven wire stretcher. A woven wire stretcher works the same way as any other wire stretcher. However, because woven wire comes in dimensional form, stretching the top, bottom, and middle of the wire at the same time is important. A shovel may also be needed to trench elevated areas in the fence line that will interfere with the bottom wires.

Laying Out a Woven Wire Fence

When laying out the wire, the first step is unrolling the wire past the corner post on the side of the post to which the wire will be attached.

Enough wire should be laid out to wrap around the post once. Three or four stays should be removed to wrap around the post cleanly.

Stays are removed in one of two ways, depending on the type of woven wire. For hinge lock fencing, the stay is cut in the middle of each block. Then, while using pliers to hold the knot, the ends of the cut wire are grabbed and twisted in the opposite direction from the knot. The sections of the stay wire should slide off the horizontal wire. For stiff stay wire, the small knot wire that holds the vertical stay in place is cut.

After removing the stays, the wire is set to the desired height against the anchor post. The wires are then wrapped around the post and tied off by splicing the end of each wire onto itself. This practice will make a solid connection for stretching.

wire are 330 feet long. The maximum length that can be stretched at one time is a quarter mile, which will consist of four rolls of wire. For

Fencing

short stretches of wire, the wire will be rolled out past the brace structure to be stretched. If two or more rolls are required, one roll is fastened to a post at each end, and then the wire rolls are stretched and spliced in the middle. An alternative method is to attach one end of the first roll to a post and then tie the other end to the next roll. The entire length is tightened at the same time. However, the wire will not be as tight as it would be if it were stretched in the middle.

Stretching Woven Wire

Wire stretching can be done in several different ways, although most stretchers operate on either a pulley system or a leverage system. Woven wire can be stretched using stretcher boards; one type of stretcher board is shown in Figure 3.3. Stretcher boards can be made of either wood or metal. Wood stretcher boards are made of 2" x 4" boards that are bolted together to hold the woven wire. Prior to stretching the wire, the position of the holes for the bolts are laid out and marked on the boards; they should be positioned to fall between the horizontal wires.

The boards are clamped together, and the top of the boards is marked. The holes are then drilled through the boards. The holes are generally $\frac{5}{16}$ to $\frac{1}{2}$ of an inch in diameter, depending on bolt size. Typically, four evenly spaced holes are needed for woven wire that is up to 5 feet tall, with more holes needed for taller fences. Metal stretcher boards can also be purchased from retailers that carry fencing supplies. On these stretcher boards, bolts for tightening the stretcher boards have been welded into position. Typically, metal stretcher boards are purchased if a large amount of fencing will be done.

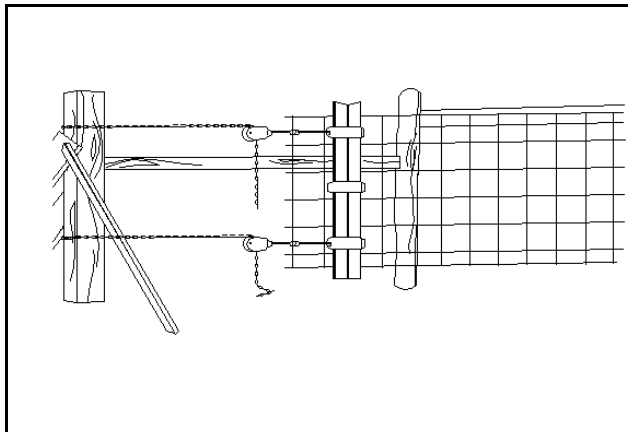

To stretch short stretches of wire from one brace structure to another, the stretcher boards are attached to the wire a few feet past the post to which the wire will be tied off. The boards should be attached in line with one vertical stay. If the boards are attached at an angle, the fence will not stretch evenly. The ends of a heavy chain are wrapped around the top and bottom of the boards. A cable winch-puller, or come-along, is attached to the chain and to a secure point, such as a truck, tractor, or another fence anchor post. If two come-alongs are available, two chains can be used with the stretcher boards instead of one.

The fence should be tensioned slowly. When the fence is properly tensioned, $\frac{1}{2}$ to $\frac{1}{4}$ of the tension bump should be removed. A tension bump is a small bend in the woven wire that acts as an aid in determining if the wire has been tightened enough. If the tension bump is completely straightened, the wire is too tight. While the fence is being stretched, it may need to be shaken to free it from snags.

Attaching Woven Wire

When the wire has been stretched, each wire is tied off, one at a time. The wire is cut at a point far enough past the post for the wire to wrap around it. Any stays that might interfere with the post should be removed. The wire can then be wrapped around the post, tied off, and stapled tightly to the post. Finally, the stretcher boards are removed.

The horizontal wires are then attached to the line posts. With wood posts, each wire is stapled tightly, so that the staple and wire are set into the post. Staples are placed crosswise with a slight downward angle, as shown in Figure 3.2. If metal posts are used, wire clips supplied by the retailer of the posts are fastened according to the manufacturer's recommendations.

Generally, for fences up to 4 feet tall, only five staples or clips are needed per post. Taller fences may require a few more fasteners. The top and bottom wires are attached at every post, while the other fasteners should be staggered on different wires at each post.

Summary

Lesson 3: Barbed and Woven Wire Fences

Barbed wire and woven wire fences are common types of fences in agriculture. The basic materials and tools needed to build these types of fences are similar: barbed or woven wire, fasteners, a claw hammer, fencing pliers, and a fence stretcher. In each case, the wire is laid out along the fence line and attached to the brace structure, stretched properly, and then attached to other brace structures and the line posts.

Credits

Ramsey, Dan. *The Complete Book of Fences*. Blue Ridge Summit, Pa.: TAB Books, Inc., 1983.

Selecting Wire Fencing Materials (G1191). University Extension agricultural publications, 1993.

Fencing

Lesson 4: High Tensile and Electric Fences

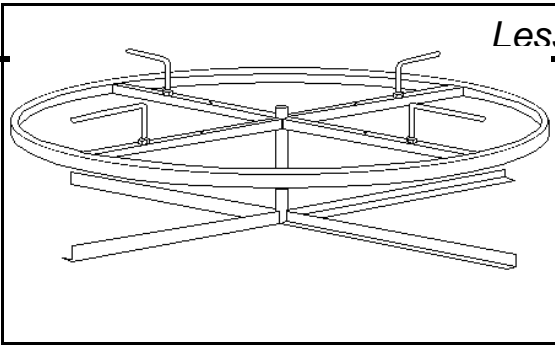

Lesson 4: High Tensile and Electric Fences

Barbed wire and woven wire fences are only two of the types of fences that may be found on agricultural operations. Other common fences are high tensile and electric fences. These types of fences have some advantages over fences made of barbed or woven wire. This lesson describes those advantages and explains the components of high tensile and electric fences and how they are constructed.

Advantages of High Tensile Fencing

High tensile wire gets its name from its tensile strength, since it can take a large amount of stress before breaking; this strength is its chief advantage. The wire is stronger and more durable than standard wire of the same gauge, which means that lighter wire can be used. A 13½-gauge high tensile wire is approximately equal in breaking strength to a 12½-gauge regular wire.

High tensile fencing also has other advantages. Because the strength of the wire makes it less prone to breakages, high tensile wire has a longer life span and lower maintenance requirements. It is also versatile, coming in a variety of forms, including strand wire, woven wire, and more decorative wire that is vinyl coated or covered with a board-like vinyl panel. This type of wire is easier to handle than barbed or woven wire, since it does not have dangerous barbs and is lighter than woven wire. High tensile fencing can easily be electrified. Finally, high tensile wire's strength makes it a good choice to replace barbed wire when the animals being fenced need protection from the barbs. A good example is show animals, where the owner wishes to avoid scars that could disfigure the animal.

Components of High Tensile Fencing

The basic components of high tensile fencing are similar to those for standard wire: high tensile wire, posts, and fasteners. Wood or steel posts may be used, although it is better not to use steel posts with an electrified fence. Wood posts may be either rounded or square. The corner posts should be at least 5 inches in diameter. Brace posts should be at least 4 inches in diameter, and line posts should be at least 3½ inches in diameter. The wire is

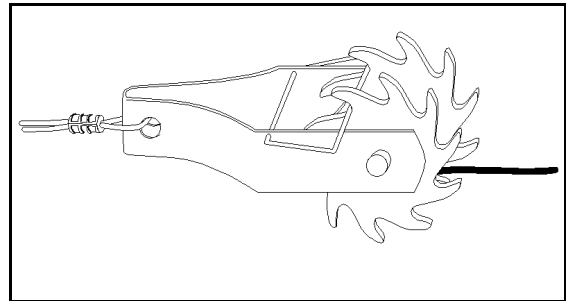

attached to the post using fasteners, either staples for wood posts or metal wire clips for steel posts. Staples should be 1¾ to 2 inches long to provide adequate holding power and keep them from pulling out of the post.

Some additional materials are used for high tensile fencing. Spacers called battens, stays, or droppers can replace some of the line posts in holding the wire in place. They are made of wood, steel, or fiberglass. Permanent in-line strainers (see Figure 4.1) or tension springs can maintain the tension of the wire over time. In-line stretchers are used for longer stretches of wire, while tension springs are only needed on short stretches of 500 feet or less.

Construction of High Tensile Fences

Some tools are needed for constructing high tensile fences. A wire spinner feeds out the wire. When using this tool, the wire is laid onto a rotating table, and L-shaped brackets then lock the wire in place and hold it as the wire uncoils. High tensile wire is springy, and attempting to work without a spinner generally leads to kinks. Also, high quality wire cutters, preferably ones designed for working with high tensile wire, should be used for cutting.

Building Fences

In construction of high tensile fences, the posts must be installed before working with the wire. The first step is to set the anchor post and brace structure. Double brace structures should be used because they can hold more tension, with loads up to 9,000 pounds, which is appropriate for longer runs of wire and large livestock. Next, the line posts, spacers, and line brace structures should be set. Line brace structures should be included in the fence at appropriate intervals and at the top and bottom of slopes. The line posts should be set 2½ feet into the ground for stability.

The distance between the line posts will vary with the purpose of the fence. For large pastures with little pressure on the fence, a good rule of thumb is placing the line posts 16 feet apart, with shorter distances used for smaller areas. The use of spacers allows the posts to be set further apart.

When the posts are set, the wire is laid out, stretched, and attached. The wires are attached working from the bottom to the top. The best method for putting up high tensile wire is to work from the middle. A spinning jenny, which is a device that aids in unrolling wire from the spool (see Figure 4.2), should be placed somewhere in the middle of the span. The first wire is pulled from the spinner to one brace structure. It is wrapped around the post twice and tied off. At the spinner, the wire is cut, and an in-line strainer is attached to the end of the wire. The wire is then pulled from the spinner to the other brace structure and tied off. At the spinner, about 3 feet of wire is run past the strainer, and then the wire is cut. The end of Electric fences have several advantages. They are low in cost, requiring fewer materials and less labor to construct than other types of fences.

this wire is placed in the strainer, and tension is taken up by turning its drum. After applying some tension to the wire, it should be loosely stapled in place. Once all the wires are in place in the fence line, the wires are tightened to the proper tension and stapled to the posts, with the wire left slightly loose in the staples so it can move as it expands and contracts due to weather conditions. To complete the fence, the wires are attached to the spacers in the fence line.

Typically, high tensile wire is electrified. If the fence is not electrified, more fence posts and stays are necessary because the posts should only be 6 to 10 feet apart in order to keep the animals in. With the posts farther apart, livestock will basically walk through the fence.

Advantages of Electric Fences

Unlike the other types of fences discussed in this unit, an electric fence is a psychological barrier, not a physical one. It operates using an electric fence charger that converts electricity into a pulse that travels along an insulated fence line. When an animal touches the wire, the current flows from the fence line, through the animal, and then through the earth to the ground system to complete the circuit, as shown in Figure 4.3. The brief shock that results keeps the animal from putting pressure on the fence. Livestock eventually become trained and avoid the fence.

Because electric fences use fewer materials and do not have to be stretched, they are quicker and easier to construct than other types of

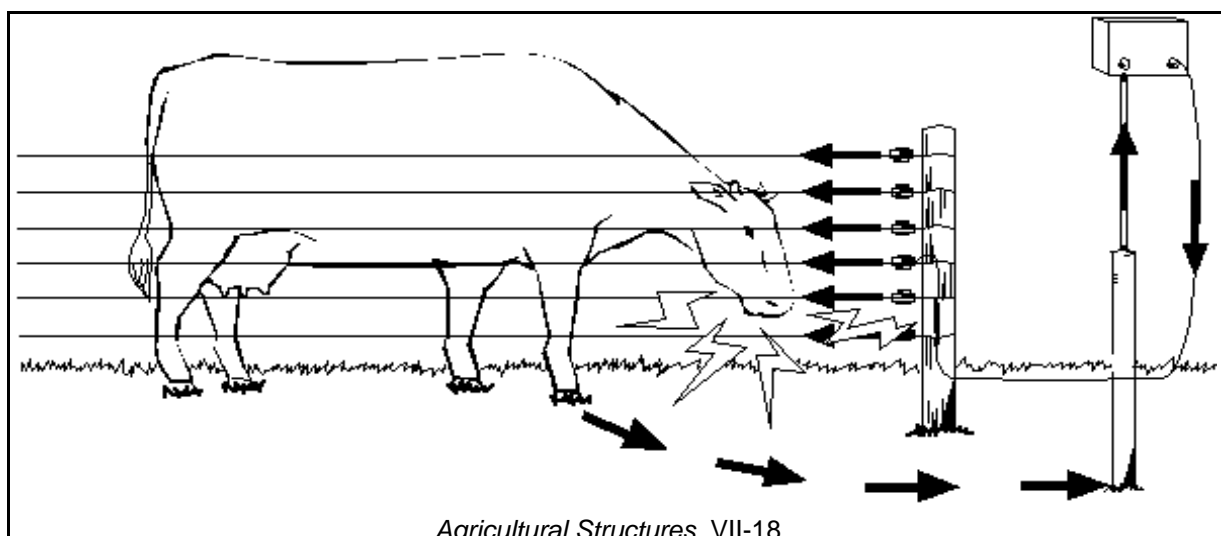

Lesson 4: High Tensile and Electric Fences

fences. Another advantage is that they are versatile; electric fences can be used for many types of animals. Because the animals generally leave the fence alone, it has a long life span. Also, no physical damage occurs when animals are shocked.

Depending on the purpose of the fence, electric fences can require a lot of maintenance. Plants growing to the point where they touch the wire may ground the system and prevent it from working effectively. Limbs falling across the wire and touching the ground will have the same effect. Livestock and wild animals, such as deer, often break smaller strands of wire when they accidentally run into them. Most fence chargers, which supply electricity to the fence, indicate whether the fence is electrified with an indicator light or by making a regular popping sound. To catch potential problems, a producer should check the charger often and walk the fence line.

Components of Electric Fencing

An important component of an electric fence is the wire that forms the fence. The best wire to use for electric fences is 12½ gauge or 14 gauge high tensile or soft wire. A smaller gauge will constrict the flow of electricity, decreasing the efficiency of the fence. High tensile wire is preferable. For temporary fences, poly wire is a useful alternative; poly-wire is a stranded polyethylene wire specifically designed for electric fences that has smaller wire conductors embedded in it.

Two other fence components are a fence charger (see Figure 4.4) and one or more ground rods. Most fence chargers convert power from a 120-volt electrical system or a battery, usually 6 or 12 volts, into the charge sent along the fence. A ground rod serves as a connection between the charger and the ground, allowing a completed circuit to be made.

Posts are also needed for electric fences. Generally, wood posts at least 5 or 6 inches in diameter are used. Steel posts may also be utilized, although good insulators are a necessity to keep them from conducting electricity. Small fiberglass rods 3 to 5 feet in length are sometimes useful when constructing a temporary

electric fence. These rods will not conduct electricity and do not require insulators.

Insulators are nonconducting wire holders that attach to the posts to hold the wire, keeping it from making a connection with the earth. Many different designs are available, as shown in Figure 4.4. For tie-off points at the end of the stretch, specialized terminal insulators made of ceramic or plastic are used. For wood line posts, brightly colored nail-on plastic insulators are often used to hold the wire, which either wraps around the insulator or passes through a bracket. An insulator called insultube is used with high tensile wire; insultube is plastic tubing that slides onto the wire and is stapled to the post. T-post insulators clip onto steel posts and hold the wire in a bracket.

A simple gate may be easily constructed using a special insulated gate handle. These insulated handles are usually made of plastic with a spring attached. One end attaches to the wire and the other has a hook that connects the fence.

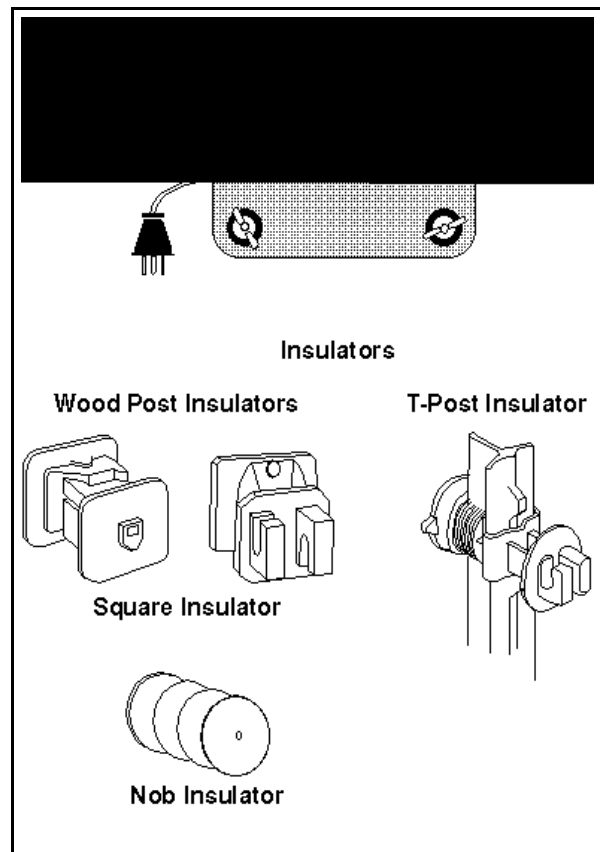

Selecting Electric Fence Chargers

Building Fences

One factor to consider when selecting a charger for an electric fence is the location of the fence, which will determine whether electricity is available. The battery types are useful for remote areas where no electrical systems are available. Some units have a solar-powered battery charger built into the charger; the batteries are recharged by sunlight. Where electricity is available, plug-in chargers should be used to take advantage of main line power.

Two related considerations when selecting chargers are the voltage put out by the charger and the length of the fence. Fencers can provide powerful electric charges, commonly up to 30,000 volts. An electric fence that has been correctly constructed can carry a charge of this intensity through miles of wire. Fence chargers generally indicate the amount of voltage they put out and how many miles of fence they can supply with power.

The amount of vegetation around the fence will affect the fence charger chosen. Grass and weeds can rob the fence of some of its power, so a fence charger that could supply power to 20 miles of fence under conditions with less vegetation would not be able to provide that much electricity to a fence overgrown with weeds.

Low impedance fence chargers are useful when vegetation is high. This type of charger increases its energy output as power is drained off by plants touching the fence. It can overcome the voltage loss caused by the vegetation.

The species of livestock will also affect the selection of a charger. Less voltage is needed for animals that have thin coats, like horses and short-haired cattle. Animals with thicker coats, like sheep or goats, require higher voltages.

Safety must be considered when choosing a charger. Any charger selected must have been approved by the Underwriters Laboratories or another reputable agency. The current from homemade fence chargers has killed livestock and people.

Constructing Electric Fences

Once a charger has been selected, it should be installed in a dry, protected area, such as a barn or shed. After installation, a ground rod must be set in place and attached to the charger.

The ground rod must be in solid contact with moist earth, which may mean driving the metal rod to a depth of up to 6 feet. Drier conditions may require the use of more than one rod. Once the ground rod is in place, a heavy wire is clamped to the top of the rod and the other end attached to the charger's ground terminal. When the posts and wire for the fence are in place, another wire is run from the positive terminal of the charger to the electric fence or to an insulated lead wire to carry the current to the fence.

If permanent posts are in place, they should be used for the fence; if not, the next step is setting the posts in place. The posts should be set to a depth of 3 to 3½ feet. The distance between the posts may vary between 20 and 50 feet. For a temporary fence, the corner and line posts are set to a depth that feels solid. They should not be driven too deep, since they will eventually be moved. Insulators should be placed on the posts at two-thirds of the height of the livestock for which the fence is being built.

Next, the wire is attached to the posts. One or two strands of wire are sufficient for an electric fence. Using at least two wires enhances the functioning of permanent and semi-permanent fences, with one wire serving as the hot wire and the other acting as a return ground in addition to the ground rod. The end of the wire is attached to the insulator on the end post, and the wire is unrolled along the fence line. Soft wire can be stretched with fence stretchers. It is then attached to the insulators. If high tensile fencing is used, the wire should be laid out and stretched as appropriate before it is attached to the insulators.

Sometimes an electric fence is used in conjunction with an existing fence. Placing a single strand of wire close to the bottom of a woven wire fence for hogs or along the top of a barbed wire fence for cattle greatly reduces the animals' contact with the fence.

Summary

In addition to barbed and woven wire, high tensile and electric fencing are options for agricultural operations. High tensile wire is useful where very strong wire is desired. Electric fencing has several advantages, including low cost and ease of construction. In

Lesson 4: *High Tensile and Electric Fences*

addition to the posts and wire needed for both types of fence, high tensile fencing requires fasteners, spacers, and permanent in-line

The basic procedure for building both types of fences consists of setting the posts and attaching the wire, although the details of the process do vary somewhat.

Credits

Bucklin, R. A., W. E. Kunkle, and R. S. Sand. "Construction of High Tensile Wire Fences." <http://gmv.ifas.ufl.edu/~fairsweb/text/ae/ae017.html> (9 Sept. 1998).

Constructing Electric Fences for Cattle (G1190). University Extension agricultural publications, 1993.

stretchers, while electric fences call for chargers, ground rods, and insulators.

Kidwell, Boyd. "Choosing a Charger." *Progressive Farmer.com* <http://progressivefarmer.com/equipment/1098/fence/choose.html> (20 May 1999).

Ramsey, Dan. *The Complete Book of Fences*. Blue Ridge Summit, Pa.: TAB Books, Inc., 1983.

Building Fences

Lesson 5: Fence Mending Techniques

Lesson 5: Fence Mending Techniques

Fences are stationary but they do get worn and broken. Repairs are generally simple, requiring a little time and a few materials. However, replacing the fence may be necessary if it is extremely worn or has extensive damage, such as that caused by age, neglect, floods, or tornadoes.

Tightening Fence Wire

Wire will loosen over time due to animals pushing against it and other stresses. If the posts are sturdy, the wire may be tightened in one of two ways. One method involves stretching the wire at a post, while the other involves stretching the wire in the middle of the fence line. In the first method, the wire is detached from an anchor post and loosened at the line posts. The next step is to stretch the wire at the anchor post as discussed in the preceding lessons. It can then be reattached to the posts. The second method involves cutting the wire in the middle of the fence. The fence stretchers are attached at this point, and the wire is stretched. Then the ends of the wire are spliced together. The tightened fence may require new fasteners but will likely give many years of continued service.

Tools for Mending Broken Wires

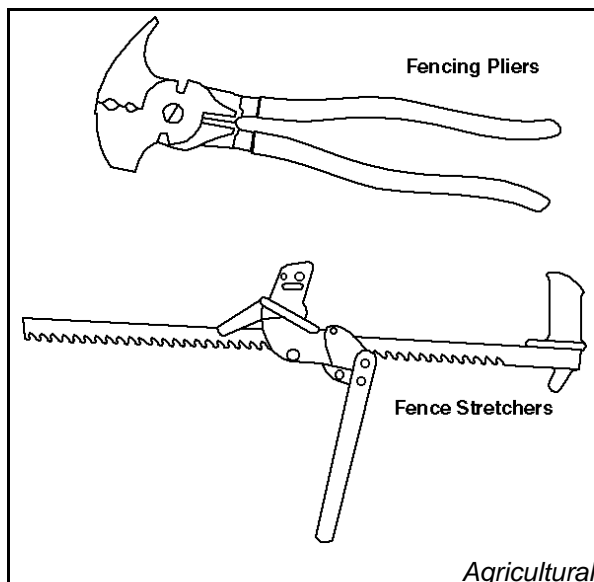

Fixing fences calls for few tools, including a claw hammer for driving staples, fencing pliers, fence stretchers for pulling the wire together, and specialized splicing tools, such as a sleeve compressor or woven wire splicing tool. Fencing pliers can replace both of these types of tools if only a small amount of repair is needed. However, they are not as convenient or fast as the other tools for more extensive repairs. Fencing pliers and fence stretchers are shown in Figure 5.1.

Methods for Splicing Fence Wire

For barbed or smooth wire, the preferred method of splicing is a crimp splice using a metal compression sleeve, shown in Figure 5.2. Both ends of the wire are threaded through the sleeve. The sleeve is then pressed together tightly using the fencing pliers.

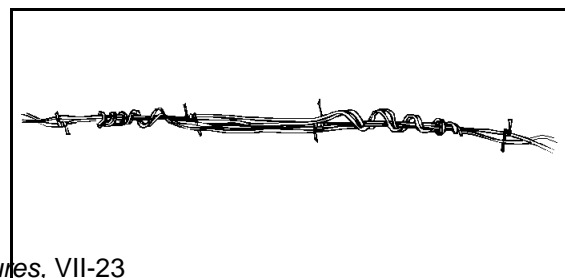
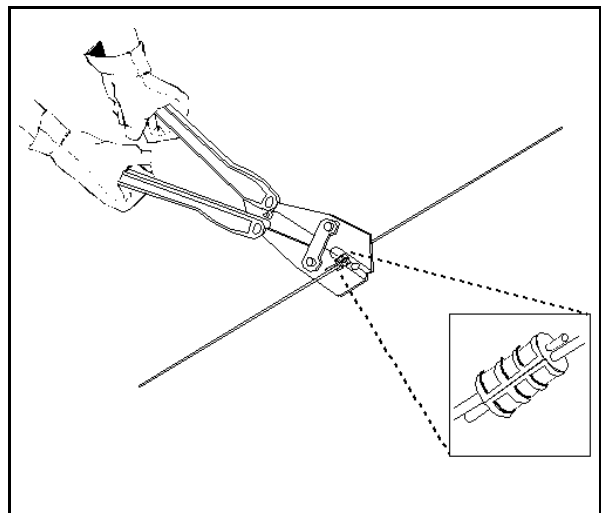

Fencing

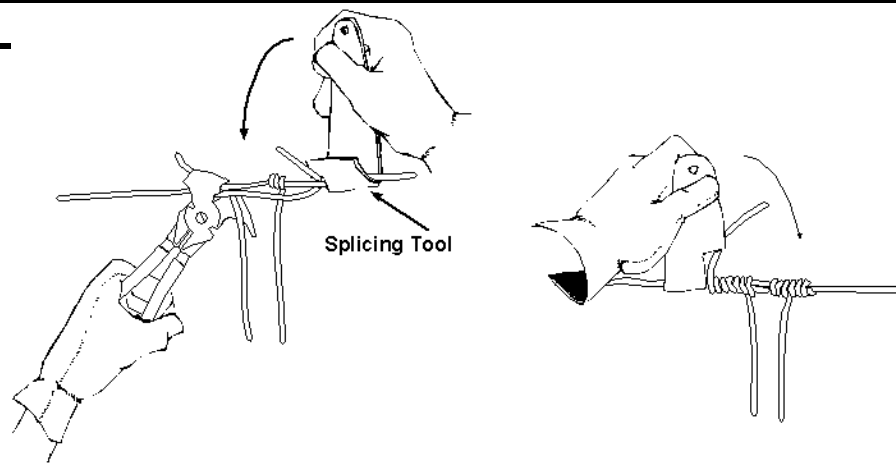

This type of wire may also be twisted together in a wrap splice with some degree of success. Figure 5.3 is an illustration of one type of wrap splice. One way to make a wrap splice is to make a loop in one wire by wrapping the tail of the wire around the wire several times. The other wire is passed through the loop and then bent back and wrapped around itself several times. This type of repair seldom produces as tight a bond as a compression sleeve. Lacerations to the hands are also more likely when performing this type of splice.

Repairs to woven wire usually involve a process similar to that shown in Figure 5.4. The wires are simply twisted together tightly using a splicing tool or pliers. These splices may cause lacerations to the hands, so heavy gloves should be worn to perform this type of repair.

Replacing Posts in Existing Fence Lines

Posts that have been broken or damaged by rot should be replaced. The wire is detached from the post, which is then removed from the ground.

Sometimes posts can be loosened by rocking them back and forth, and they are then pulled out by hand. Posts may also be removed using post pullers or a jack.

Sometimes a post breaks off at ground level. If possible, the new post is set to one side of the old post. If positioning the post in this way is not possible, digging up the old post is

necessary before a new one can be set in the same place.

After the old post is removed, the new one is set in place using the same methods for setting posts that are utilized when a fence is constructed, as discussed in Lesson 2 of this unit.

The person setting the posts in an existing fence line should be careful, since she or he will have to work in close proximity to the existing wire.

Summary

Fence repairs are frequent in agricultural settings.

Loose fence wires can be tightened either at an anchor post or in the middle of the fence line. Only a few tools are necessary to mend broken wires, which can be fixed using a metal sleeve compressor or by twisting the wire together in some way. If posts in an existing fence line need to be replaced, they should be removed, and new posts set in their place.

Credits

Ramsey, Dan. *The Complete Book of Fences*. Blue Ridge Summit, Pa.: TAB Books, Inc., 1983.

Selecting Wire Fencing Materials (G1191). University Extension agricultural publications, 1993.